

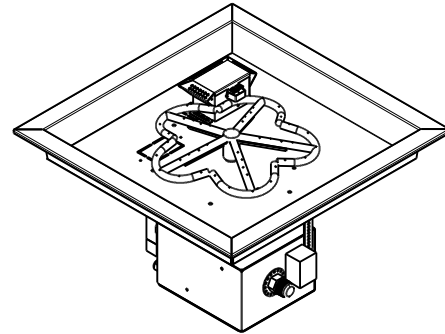

Hearth Products Controls Co
CSA CERTIFIED-OUTDOOR USE ONLY
FOR COMMERCIAL AND RESIDENTIAL USE

HEARTH PRODUCTS CONTROLS
 3050 PLAINFIELD RD.
 KETTERING, OH 45432
 TOLL FREE: 1-877-433-7001
 PHONE: (937) 433-7000
 FAX: (937) 433-0704
 www.hpcfire.com

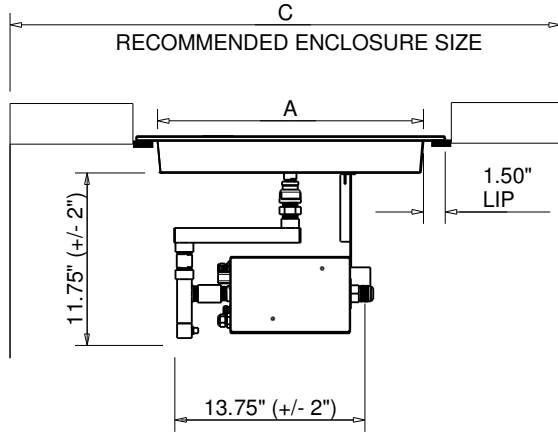

ISOMETRIC VIEW

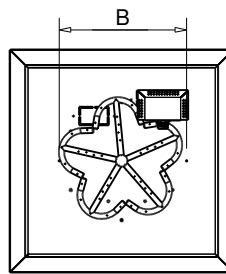

PLAN VIEW

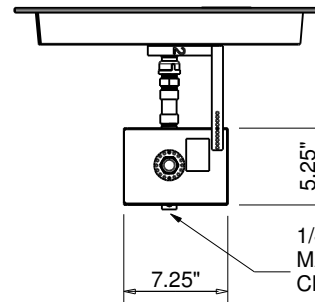

SIDE ELEVATION

AVAILABLE IN:

- 120VAC OR 24VAC
- On/Off OR Hi/Low

MATERIAL: 304 STAINLESS STEEL

Hi/Lo MODELS HAVE A 40% REDUCTION IN BTU ON LOW SETTING

PART NUMBERS	STND BTU	DIMENSION CHART		
		A"	B"	C"
18SSEI-SQBL	65K	18	12	54
24SSEI-SQBL	125K	24	18	54
30SSEI-SQBL	200K	30	24	54
36SSEI-SQBL	250K	36	30	72
42SSEI-SQBL	400K	42	36	80

Notes:

- PROPER VENTING
 - ENCLOSURES: Recommend 4 each 18 sq.in. vents on opposing sides (Minimum 2 each 18 sq.in. vents).
 - BOWLS (Copper, concrete or metal) - Bowl to be raised above mounting surface minimum of 3/4" gap; Bowl to have a minimum of 6" diameter hole in bottom
- GAS SUPPLY - FOR USE WITH FIXED PIPING SYSTEMS ONLY - NOT FOR USE WITH SMALL TANKS.
 - Natural Gas: Operating Supply Pressure: Minimum: 6.0" W.C.; Maximum: 7.0" W.C.
 - LP Gas: Operating Supply Pressure: Minimum: 10.0" W.C.; Maximum: 11.0" W.C.

IMPORTANT: Ensure any flex line that may be used from the permanent main fuel supply to the product is rated to the stated max btu of the product and certified to ANSI Z21.75*CSA 6.27.

- MODIFICATION OF PRODUCT WILL VOID ANY CERTIFICATION AND WARRANTY.
- FOLLOW ALL MANUFACTURER INSTALLATION INSTRUCTIONS AND LOCAL CODES.
- ALL DIMENSIONS ARE CONSIDERED TRUE AND REFLECT MANUFACTURER'S SPECIFICATIONS AS OF THE REVISION DATE.
- DO NOT SCALE DRAWING.
- THESE DRAWINGS ARE FOR SIZING AND PLANNING PURPOSES. ALL INFORMATION CONTAINED HEREIN WAS CURRENT AT THE TIME OF DEVELOPMENT. THE MANUFACTURER'S RESPONSIBLE FOR THE ACCURACY OF THE DRAWING.
- CONTRACTOR'S NOTE: FOR PRODUCT AND COMPANY INFORMATION VISIT www.CADdetails.com/info REFERENCE NUMBER 771-061.

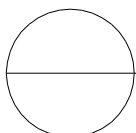

ELECTRONIC IGNITION

EI SQUARE BOWL PAN- FLAME SENSING WITH ELECTRONIC HOT SURFACE IGNITION