

# INSTALLATION & OPERATION MANUAL

MODEL NUMBERS: 13-NCI      50-SNC13I      50-TNC13I

*Thank you for purchasing this product from a fine line of heating equipment.  
We wish you many years of safe heating pleasure with your new heating appliance.*

***Save These Instructions.***

**NOTE: IF YOU HAVE A PROBLEM WITH THIS UNIT DO NOT RETURN IT TO THE DEALER. CONTACT TECHNICAL SUPPORT @ 1-800-245-6489.**

Questions? Need Parts or Options? [www.englanderstoves.com](http://www.englanderstoves.com)

---

---

**Please Note the Following Precautionary Statements:**

England's Stove Works highly recommends the use of smoke detectors and Carbon Monoxide detectors with any hearth product, including this unit. Follow all manufacturer's instructions when using smoke or Carbon Monoxide detectors.

**CAUTION:** This unit must be installed in accordance with these instructions and must comply with local building and fire codes. Failure to do so could result in a chimney or house fire.

Keep children, furniture, fixtures, and all combustible materials away from any heating appliance. Refer to this owner's manual for all clearances to combustible materials.

**DO NOT INSTALL THIS UNIT IN A MOBILE HOME OR DOUBLE WIDE!!!**

**DO NOT INSTALL THIS UNIT IN A PRE-MANUFACTURED FIREPLACE!!!**

**FOR MASONRY FIREPLACE INSTALLATION ONLY!!!**

SAVE THIS MANUAL FOR FUTURE REFERENCE

Read this entire manual before you install and use your new room heater. If this room heater is not properly installed, a house fire may result. To reduce the risk of fire, follow the installation instructions. Failure to follow instructions may result in property damage, bodily injury, or even death.

Rev. 9/2014



**A letter from our Technical Support department:**

**Thank you for purchasing this fine product from England's Stove Works!**

England's Stove Works was started, and is still owned by, a family that believes strongly in a "Do It Yourself" spirit – that's one reason you found this product at your favorite "Do It Yourself" store.

We intentionally design and build our stoves so that any homeowner can maintain his or her unit with basic tools, and we're always more than happy to show you how to do the job as easily and as inexpensively as possible.

From our free, downloadable service sheets, to our new "wizard-style," click-through Troubleshooting guide on our web site, we have always tried to help our customers stay "heat-ready," especially when oil and electricity prices continue to skyrocket.

Please look at our vast Help section on our web site and call our Technical support department at (800) 245-6489 if you need any help with your unit. We are nearly always able to help "walk you through" any repairs, problems or questions you may have.

**PLEASE NOTE:** While information obtained on our web site and through our 800 number is always free of charge, there will be a service charge incurred with any "on-site" repairs or maintenance that we may arrange.

*Wishing you years of efficient, quality and "comfy" heating,*  
England's Stove Works  
Technical Support Department

[www.englishstoves.com](http://www.englishstoves.com)

**(800) 245-6489**

<p>IF YOU HAVE A PROBLEM WITH THIS UNIT DO NOT RETURN IT TO THE DEALER. CONTACT CUSTOMER SERVICE at 1 (800) 245-6489.</p>
---

## CAUTION

We highly recommend installation of this fireplace insert by a professional installer.

The “Direct Connect” method of installation must be used (see Installation section of manual).

If you have any doubt concerning your ability to complete your installation in a professional-like manner after reading these instructions, you should obtain the services of an installer who is versed in all aspects as to the correct and safe installation. **Do not** use temporary, makeshift compromises during installation. **Do** follow all applicable codes.

## BEFORE INSTALLATION OF YOUR APPLIANCE

- 1. HOT WHILE IN OPERATION. KEEP CHILDREN, CLOTHING AND FURNITURE AWAY. CONTACT MAY CAUSE SKIN BURNS.**
- 2. DO NOT BURN GARBAGE OR FLAMMABLE FLUIDS.**
3. Check with the building inspector’s office for compliance with local codes; a permit may be required.
4. Always connect this unit to a chimney and **NEVER** vent to another room or inside a building.
5. **DO NOT** connect to any duct work to which another appliance is connected, such as a furnace.
6. **DO NOT** connect this unit to a chimney flue serving another appliance.
- 7. DO NOT USE CHEMICALS OR FLUIDS TO START THE FIRE.**
8. The connector pipe and chimney should be inspected periodically and cleaned if necessary.
9. Remember the clearance distances when you place furniture or other objects within the area. **DO NOT** store wood, flammable liquids or other combustible materials too close to the unit.
10. Contact your local fire authority for information on how to handle a chimney fire. Have a clearly understood plan to handle a chimney fire. In the event of a chimney fire, turn air control to a closed position and **CALL THE FIRE DEPARTMENT.**
11. DO NOT tamper with the combustion air control beyond normal adjustment.
12. Once the required draw is obtained, operate only with doors closed; open doors slowly when re-fueling (this will reduce or eliminate smoke from entering the room).
13. DO NOT install these units in a mobile home or trailer. These units are NOT mobile home approved.
14. Visit our web site at [www.englishstoves.com](http://www.englishstoves.com) for helpful information, frequently asked questions, parts/accessory orders and more. **Technical support: (800) 245-6489.**

## SAFETY NOTICE:

**IF THIS STOVE IS NOT PROPERLY INSTALLED, A HOUSE FIRE MAY RESULT. FOR YOUR SAFETY, FOLLOW THE INSTALLATION DIRECTIONS. CONTACT LOCAL BUILDING OR FIRE OFFICIALS FOR RESTRICTIONS AND INSPECTIONS IN YOUR AREA.**

## SECTION I: FLUE SYSTEM

This stove is designed to install into a masonry fireplace. The minimum opening is 28" wide x 24" high x 16" deep and you must have at least fourteen inches (14") of hearth extending from the fireplace face.

### Flue Size Needed:

The proper flue size is normally determined by the inside diameter of the opening on the unit, which in this case is six inches (6"). Therefore, the connector pipe should be the same size or larger and never less in diameter than the opening on the stove. The area of the chimney liner in square inches must also be equal to or larger than the area of the opening on the stove. If the area of the flue is larger than the area of the opening on the stove, it should never be more than three (3) times larger.

## SECTION II: INSTALLATION INTO A MASONRY FIREPLACE

### A. Preparation

1. Measure your hearth to ensure it is large enough to accept the unit. Your hearth should be at least thirty-six inches (36") wide and fourteen inches (14") from the face of the fireplace to the edge of the hearth.
2. Inspect your hearth to be sure it is constructed of a noncombustible material such as brick or stone. Do **not** install this stove on a hearth that is constructed of wood framework that is covered by brick or stone and do **not** install this unit in a zero (0) clearance fireplace. The manufacturer will not be held responsible for an accident resulting from this stove being installed on a hearth constructed of a combustible material.
3. Inspect your fireplace to ensure it is in proper working order and free of any obstructions.
4. Prior to installation, remove the existing damper or wire it to fasten it open.
5. Place the insert on the hearth and slide about one-third (1/3) of it into the opening.

### B. Venting Your Insert

#### Direct Connect

When this unit is direct connected it will require six inch (6") diameter 24 gauge pipe from the stove through the damper opening. **(NOTE: The chimney connector must be attached to the appliance with a minimum of three (3) screws, and 3 screws should be used to attach each adjoining section.)** This will make it necessary to block off the open area on both sides of the pipe that passes through the damper opening, which can be done with sheet metal or by packing flame retardant fiberglass insulation in the open areas (no paper or combustibles). You must be sure the draft from the chimney is being pulled through the stove, and not around the connector pipe. (See Illustration 3 and "Backplate Instructions"). We highly recommend you have this done by a professional. You should contact your local authorities to be sure you are following all codes.

**\*IMPROPER INSTALLATION:** The manufacturer will not be held responsible for damage caused by the malfunction of a stove due to improper installation. Do not use makeshift methods or material which may compromise the installation. England's will not be liable for consequential or indirect damages to property or persons resulting from the use of this product. Call (800-245-6489) and/or consult a professional installer if you have any questions.

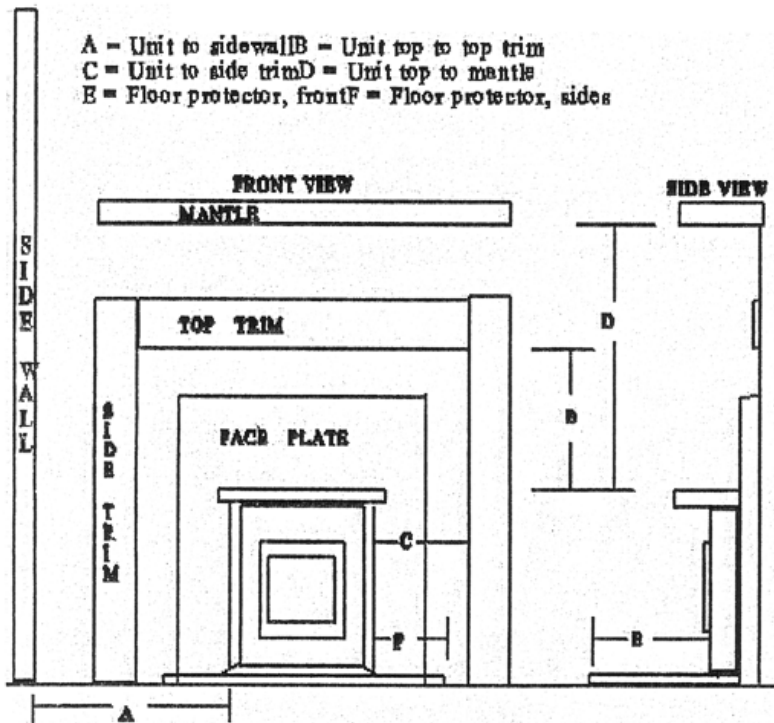

**CLEARANCES:**

- A = 13 inches (330 mm)
- B = 16 inches (407 mm)
- C = 11 inches (280 mm)
- D = 20 inches (508 mm)
- E = 16 inches (407 mm)
- F = 8 inches (204 mm)

Illustration 1

**SECTION III: IMPORTANT OPERATION INSTRUCTIONS**

“Draft” is the force that moves air from the appliance up through the chimney. The amount of draft in your chimney depends on the length of the chimney, local geography, nearby obstructions, and other factors. Too much draft may cause excessive temperatures in the appliance. An uncontrolled burn or a glowing red part or chimney connector can indicate excessive draft. Inadequate draft may cause back puffing into the room and “plugging” of the chimney and/or cause the appliance to leak smoke into the room through appliance and connections.

Today’s solid fuel appliances are much more efficient than in the past. The units are designed to give you controlled combustion, as well as maximum heat transfer, using less fuel to do so.

The design of your new appliance is such that the exhaust “smoke” is now at lower temperatures than in the past, therefore requiring proper chimney size to give adequate draft. If your chimney is too large, the heating appliance will have a difficult time to raise the “chimney flue” temperature to give adequate draft, therefore causing a smoke back up, poor burn, or both.

**Should you experience such problems, call in a local chimney expert.**

With the door closed, the rate of burning is regulated by the amount of air allowed to enter the unit through the air control. With experience, you will be able to set the control for heat and burning time desired.

Attempts to achieve higher output rates that exceed heater design specifications can result in permanent damage to the heater. The recommended wood load is level with the top of the firebricks. Overloading may prevent sufficient air entering the heater to properly fuel the fire.

Do not tamper with the combustion air control beyond the normal adjustment capacity.

Operate this heater only with the door closed.

**ALWAYS PROVIDE A SOURCE OF FRESH AIR INTO THE ROOM WHERE THE UNIT IS INSTALLED. FAILURE TO DO SO MAY RESULT IN AIR STARVATION OF OTHER FUEL BURNING APPLIANCES AND THE POSSIBLE DEVELOPMENT OF HAZARDOUS CONDITIONS.**

**THIS HEATER IS EXTREMELY HOT WHILE IN OPERATION. SERIOUS BURNS CAN RESULT FROM CONTACT. CAUTION SHOULD BE OBSERVED, ESPECIALLY WHEN CHILDREN ARE PRESENT.**

**BLOWER ASSEMBLY: MODEL AC-13BA  
115 VOLTS, 60 Hz, 0.83 AMPS, 3060 RPM  
DANGER: RISK OF ELECTRIC SHOCK. DISCONNECT POWER BEFORE SERVICING.**

***BLOWER MOTOR OPERATING INSTRUCTIONS:***

This unit is set up with a variable speed blower motor. The fan speed should be run on “Low” when the unit is operating at lower burn settings, and set to “High” for high burns. The blower will move air under, around and exit over the top of the front of the stove.

**BLOWER INSTALLATION:**

To install the blower, simply place it under the ash lip in the front of the stove. The blower should be removed and cleaned at least once per year; you can use a vacuum cleaner to remove any loose dust build-up, but DO NOT disassemble the blower. The blower should not require any oil.

When routing power cord, be sure that the cord does not come into contact with any hot surface.

## **SECTION IV: Optional Brass Trim**

The AC-105 trim kit covers the two front edges of the stove and the three edges of the cover plate. The stove lip trim simply snaps over the edges of the stove. There are two angle clips that hold the three pieces of cover plate trim together – connect the three edges together and slide from the top down over the cover plate edges. The top piece of trim must be forced out slightly so it will connect with the top edge of the plate.

## SECTION V: FLOOR PROTECTION

### Hearth Extension

The firebox on your insert will extend out eight inches (8") from the face of the fireplace, so you will need at least sixteen inches (16") in front of the door. If you do not have this, it will require you to place an approved floor protector in front of the stove (such as a hearth extender shield).

#### Alternate Floor Protection:

An easy means of determining if a proposed alternate floor protector meets requirements is to follow this procedure:

- 1) Convert specification to R-value:
  - i R-value is given – no conversion is needed
  - ii k-factor is given with a required thickness (T) in inches:  $R = 1/k \times T$
  - iii C-factor is given:  $R = 1/C$
- 2) Determine the R-value of the proposed alternate floor protector:
  - i Use the correct formula given in step 1 (above) to convert values not expressed as "R."
  - ii For multiple layers, add R-values of each layer to determine overall R-value.
- 3) If the overall R-value of the system is greater than the R-value of the specified floor protector, the alternate is acceptable.

#### EXAMPLE:

The specified floor protector should be  $\frac{3}{4}$ " thick material with a k-factor of 0.84. The proposed alternate is 4" brick with a C-factor of 1.25 over  $\frac{1}{8}$ " mineral board with a k-factor of 0.29.

**Step (a):** Use formula above to convert specification to R-value.

$$R = 1/k \times T = 1/0.84 \times .75 = 0.893$$

**Step (b):** Calculate R of proposed system.

$$4" \text{ brick of } C = 1.25, \text{ therefore } R_{\text{brick}} = 1/C = 1/1.25 = 0.80$$

$$\frac{1}{8}" \text{ mineral board of } k = 0.29, \text{ therefore } R_{\text{min.bd.}} = 1/0.29 \times 0.125 = 0.431$$

$$\text{Total } R = R_{\text{brick}} + R_{\text{mineral board}} = 0.8 + 0.431 = 1.231$$

**Step (c):** Compare proposed system of R of 1.231 to specified R of 0.893.

Since proposed system R is greater than required, the system is acceptable.

#### Definitions:

$$\text{Thermal conductance} = C = \frac{\text{Btu}}{(\text{hr})(\text{ft}^2)(\text{deg F})} = \frac{\text{W}}{(\text{m}^2)(\text{deg K})}$$

$$\text{Thermal conductivity} = k = \frac{(\text{Btu})(\text{inch})}{(\text{hr})(\text{ft}^2)(\text{deg F})} = \frac{\text{W}}{(\text{m})(\text{deg K})} = \frac{\text{Btu}}{(\text{hr})(\text{ft})(\text{deg F})}$$

$$\text{Thermal resistance} = R = \frac{(\text{ft}^2)(\text{hr})(\text{deg F})}{\text{Btu}} = \frac{(\text{m}^2)(\text{deg K})}{\text{W}}$$

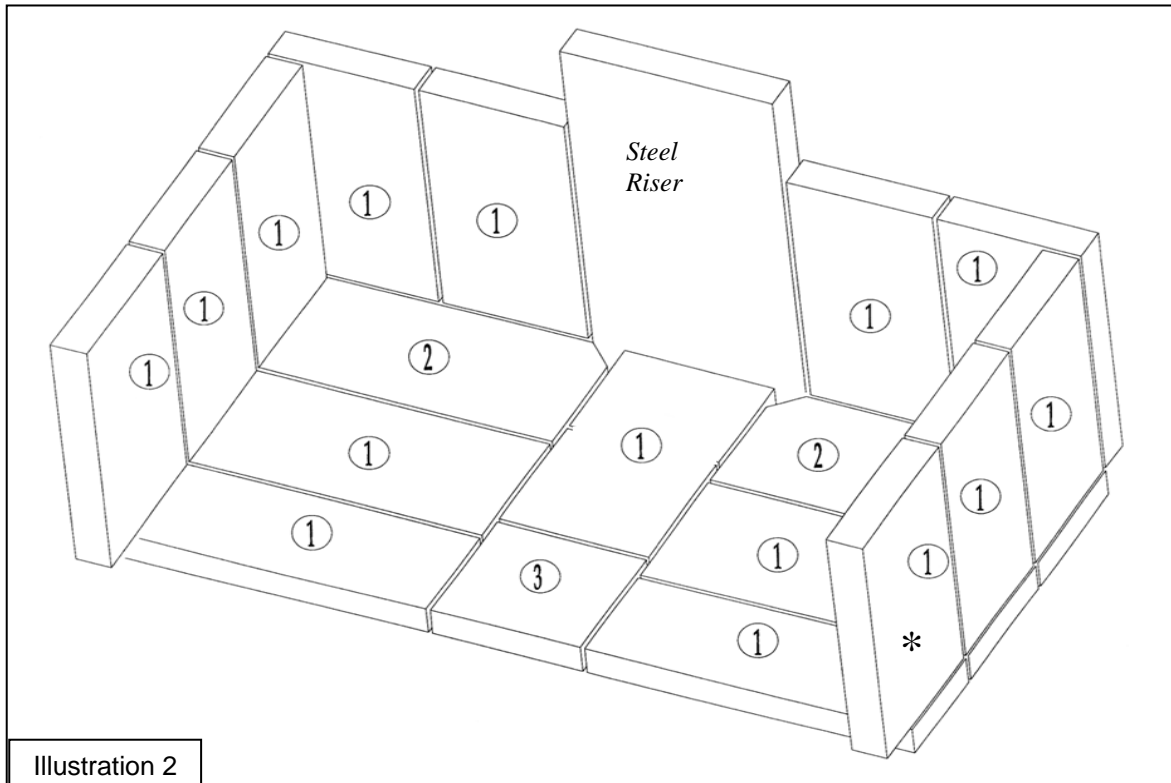

Illustration 2

**BRICK LAYOUT**  
 1 – 9" x 4" x 1.25" brick (Qty. 15\*)  
 2 – 9" x 4" x 1.25" brick w/ .75 x .75 notch (Qty. 2)  
 3 – 4" x 2" x 1.25" brick (Qty. 1)

\*Note- Front brick where door wedge closes is actually notched – Part Number AC-SBN, 9" x 4" x 1.25" brick with 1" x 3" notch, qty. 1

**NOTES:**



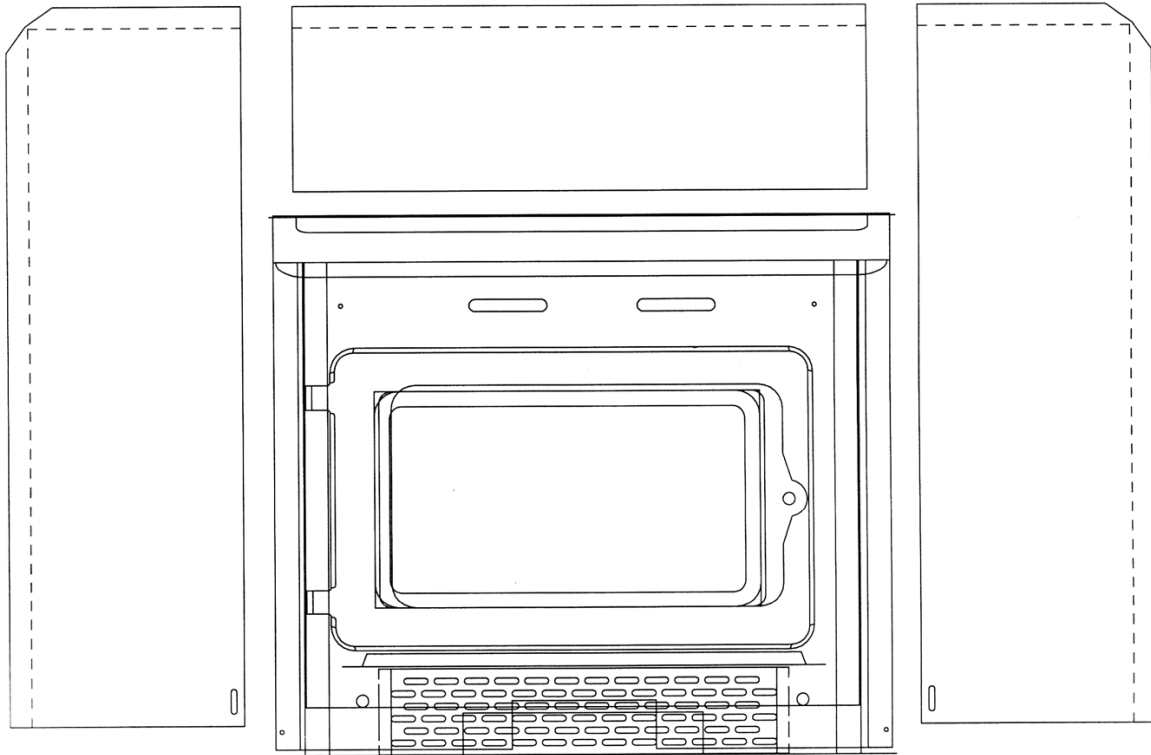
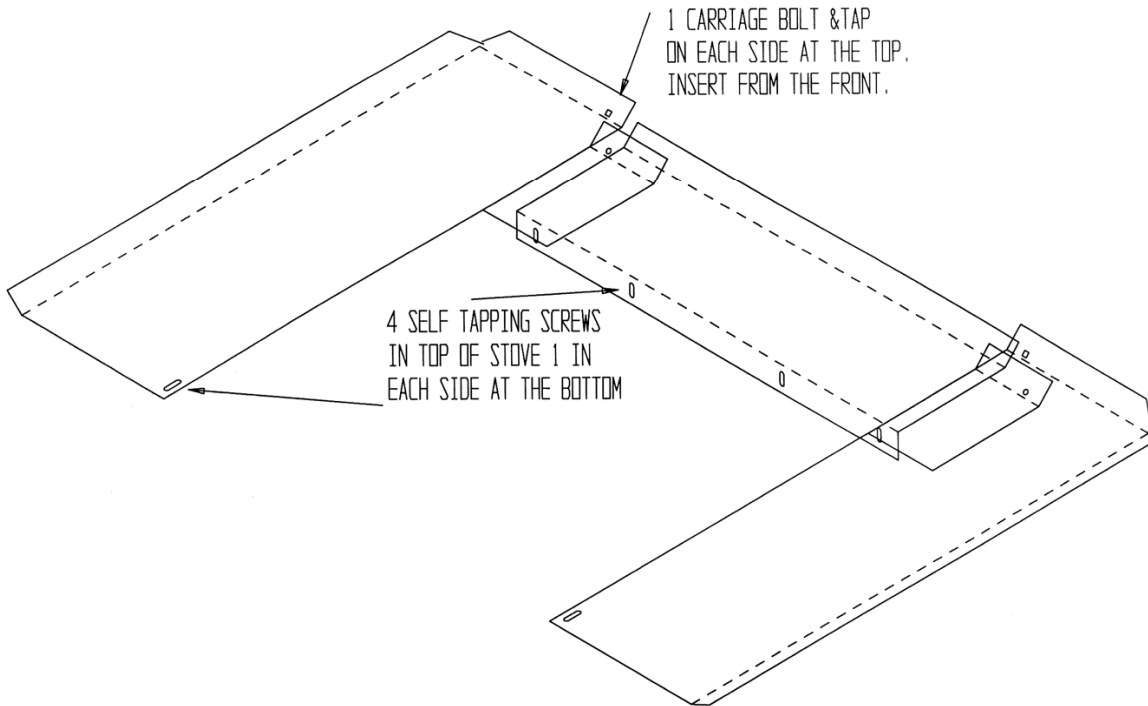

Illustration 3



**BACKPLATE INFORMATION:**

Your backplate is a three (3) section plate that needs to be assembled before installation on your insert unit. A roll of insulation is also included, which needs to be installed around the outside perimeter of the plate (even with the “bend line”), and at the two connection joints to insure a proper seal between the plate and the hearth.

## SECTION VI: NOTES ON PLACEMENT

The first challenge you may encounter is getting your stove into your home -- all of our stove products are well constructed, which makes them rather heavy. Three to four adults can normally handle a unit, but we still recommend using a handcart. Never attempt to handle a heating product alone!!! The door and brick can be temporarily removed to lighten the unit (refer to Brick Layout). After the unit is placed into position, install the spring handles and attach any optional equipment.

## SECTION VII: OPERATION

Do not use a grate or elevate the fire. Build the wood fire directly on the bricks. When the stove is used for the first time, solvents in the paint will smoke off as the stove “cures.”

### WOOD –

This heater is designed to burn natural wood only. Higher efficiency and lower emissions generally result when burning air-dried seasoned hardwood, as compared to softwood or to green or freshly-cut hardwood.

Use only dry, seasoned wood. Green wood, besides burning at only 60 percent of the fuel value of dry wood, deposits creosote on the inside of the stove and along the chimney. This can cause extreme danger of chimney fire. **To be called “seasoned,” wood must be dried for a year.** Regardless of whether the wood is green or seasoned, it should be stored in a ventilated, sheltered area to allow proper drying during the year. Wood should be stored beyond recommended clearances from combustibles.

### **DO NOT BURN:**

**Treated Wood, Garbage, Solvents, Trash, Cardboard, Colored Paper or Coal.**

### FIRST FIRE –

- Remember to ventilate well.
- Allow the stove to cure before burning for long periods of time at high temperatures.
- Flat spots on the painted surface are normal.
- Shiny spots on the painted surface (before burning) are normal.
- Call Technical support at (800) 245-6489 if you have any questions.

## SECTION VIII: BUILDING A FIRE

1. Open the air inlet control fully.
2. Place a small amount of crumpled paper in the stove.
3. Cover the paper with a generous amount of kindling in a “teepee” shape, and a few small pieces of wood.
4. Ignite this fuel and close the door most of the way (leave it open slightly).
5. Add larger pieces of wood as the fire progresses, being careful not to overload. Do not fill the firebox beyond the firebrick area. A coal bed of (ideally) 1” to 2” should be established to achieve optimum performance.

6. This unit is designed to function most effectively when air is allowed to circulate to all areas of the firebox. A good way of achieving this is to rake a small (1" to 2" wide) "trough" in the center of the coal bed, from front to back, prior to loading the fuel.
7. Once fuel has been loaded, close the door and fully open the air inlet control, until the fire is well established (approximately 20 minutes), being careful not to over-fire.
8. Readjust the air inlet control to the desired burn rate. If excessive smoke fills the firebox, open the air inlet control slightly, until flames resume and the wood is sufficiently ignited. Basically, Closed = "Low;" ½ Way Open = "Medium;" and Fully Open = "High."
9. **When refueling, adjust the air control to the fully open position.** When the fire brightens, open the door **VERY** slowly and carefully. This will prevent gases from igniting and causing smoke and flame spillage.
10. At this point you may add fuel, being careful not to overload.

**NEVER USE GASOLINE, GASOLINE-TYPE LANTERN FUEL, KEROSENE, CHARCOAL LIGHTER FLUID, OR SIMILAR LIQUIDS TO START OR 'FRESHEN UP' A FIRE IN THIS HEATER. KEEP ALL SUCH LIQUIDS WELL AWAY FROM THE HEATER WHILE IT IS IN USE.**

<b>CONTROL SETTINGS</b>	
<b><u>Burn Rate</u></b>	<b><u>Inlet Air Setting</u></b>
Low	Fully Closed
Med. Low	¼ Open
Med. High	¾ Open
High	Fully Open

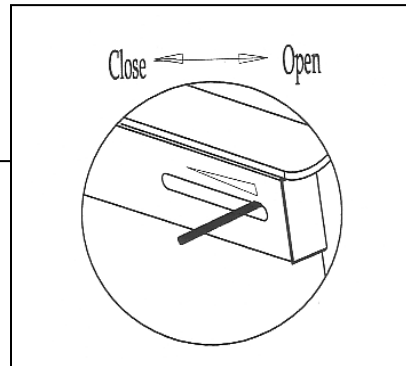

Illustration 4 – Air Inlet Control

## SECTION IX: GLASS CARE

**REPLACE GLASS ONLY WITH HIGH-TEMPERATURE ROBAX PYROCERAM OF THE PROPER SIZE AND THICKNESS.**

The following use and safety tips should be observed:

1. Inspect the glass regularly for cracks or breaks. If you detect a crack or a break, extinguish the fire immediately, and contact your dealer or Technical support at (800) 245-6489 for replacement (or log on to [www.englishstoves.com](http://www.englishstoves.com) ).
2. Do not slam the door or otherwise impact the glass. When closing doors, make sure that logs or other objects do not protrude and impact the glass.

3. Do not clean the glass with materials which may scratch (or otherwise damage) the glass. While surface scratches are acceptable, deeper scratches on the glass can develop into cracks or breaks.
4. Never attempt to clean the glass while the unit is hot. If the deposit is not very heavy, normal glass cleaners are adequate with a plain, non-abrasive scouring pad. Heavier deposits may be removed with the use of an oven cleaner.
5. NEVER put substances that can ignite explosively inside the unit, since even small explosions in confined areas can “blow out” the glass.
6. This unit has an airwash system, designed to reduce deposits on the glass.

## **SECTION X: GASKET REPLACEMENT**

After extensive use, the sealing material which provides glass and door seal may need to be replaced if it does not sustain its resilience. Inspect the glass and door seal periodically to ensure proper seal. If the gaskets become frayed or worn, replace immediately. Contact your dealer or Technical support at (800) 245-6489 for approved replacement parts.

*The following steps should be followed for replacement of the glass gasket:*

1. Ensure that the appliance is not in operation, and is thoroughly cooled.
2. Remove the screws and glass clips.
3. Lift glass out from glass clips.
4. Remove the old gasket, and clean the glass.
5. Replace the new gasket, starting at the bottom of the glass and working along the edges. Be sure to center the gasket channel on the glass.
6. Trim the gasket to length and butt the ends together.
7. Replace the glass in the door, being sure not to over-tighten the screw and clip.

*The following steps should be followed for replacement of the door gasket:*

1. Ensure the appliance is not in operation and is thoroughly cooled.
2. Remove the old door gasket and clean the gasket channel.
3. Using an approved high-temperature gasket cement, apply a thin coat in the bottom of the channel.
4. Starting at the hinge side of the door, work into the channel around the door unit, trim to length and butt the ends together.
5. Close the door and allow three to four hours for the cement to set before restarting any fire.

**Front (Door Side)**  
 **of Unit**

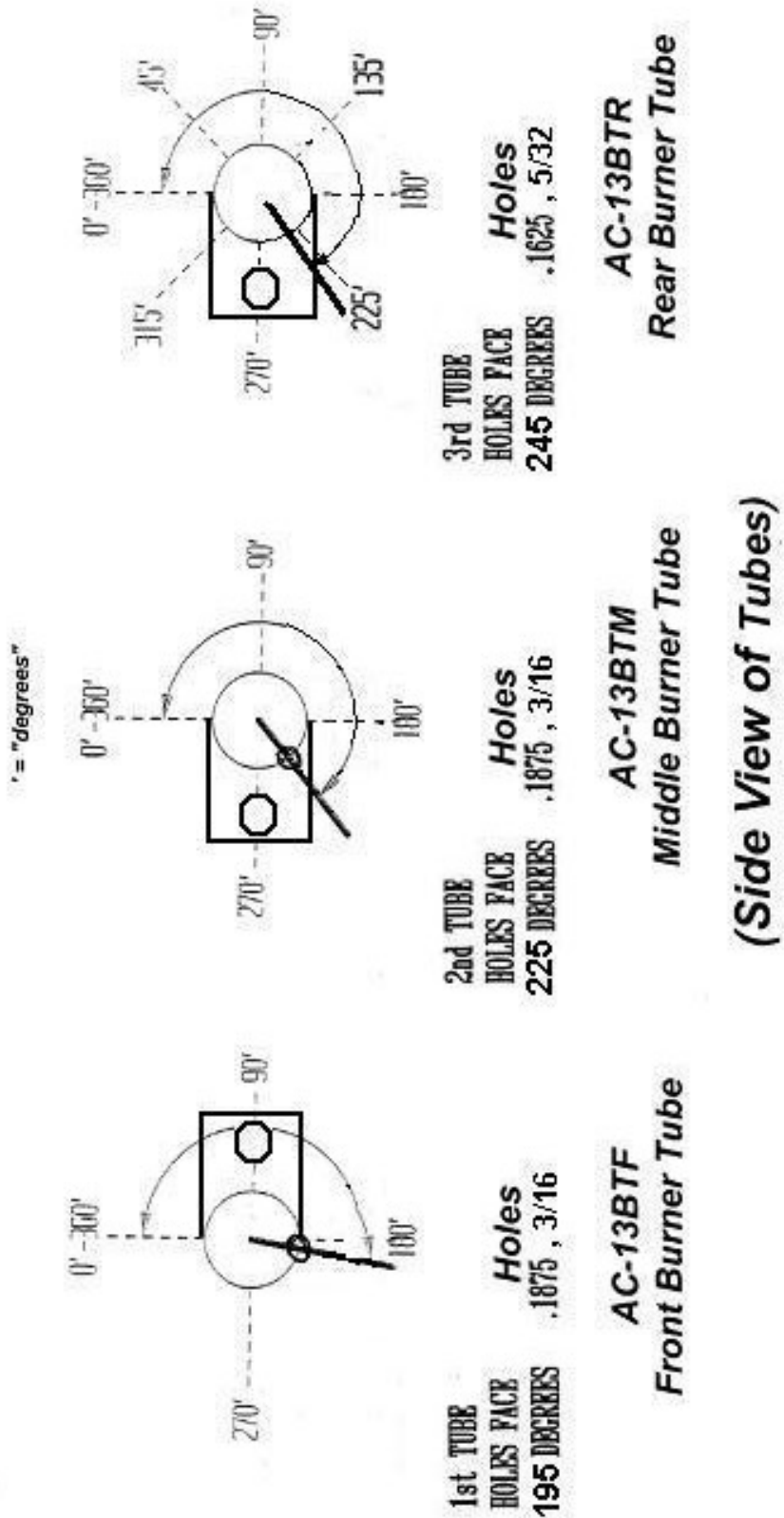

**(Side View of Tubes)**

Placement of Stainless Steel Burner Tubes for all 13-NC, 50-SNC13 and 50-TNC13  
 (freestanding and insert) stove models.

## SECTION XI: FIBER BOARD: CARE & MAINTENANCE

THIS WOOD HEATER UTILIZES NEW TECHNOLOGY, WHICH INCLUDES A CERAMIC FIBER BOARD THAT IS LOCATED IN THE FIREBOX, AND RESTS ON TOP OF THREE (3) STAINLESS STEEL TUBES.

***DO NOT REMOVE THIS CERAMIC FIBER BOARD!!!***

IT IS A NECESSARY COMPONENT OF THE FIREBOX.

ALSO PLEASE NOTE: THE CERAMIC FIBER BOARD MAY BECOME LOOSE DURING INITIAL SHIPPING. BE SURE IT IS LYING FLAT, ON TOP OF THE THREE STAINLESS STEEL TUBES, AND PUSHED ALL THE WAY TO THE BACK OF THE UNIT, WITH NO GAPS BETWEEN IT AND THE BACK WALL.

Call (800) 245-6489 if questions.

MAINTENANCE: This unit is equipped with a ceramic Fiber Board ceiling baffle. After extensive use, the board should be removed and cleaned.

The following steps should be followed for cleaning or replacement:

1. Ensure the appliance is not in operation and is completely cooled down.
2. There is one screw in each stainless steel tube holder, located in the fire box ceiling. Remove the screws from the front and middle tube holders.
3. Shift the tube to the right, so that one end comes completely out of the socket. Drop the end down and pull it out by pulling it back to the left.
4. Drop the board down and push the left corner to the top left. Bring the right corner down to the bottom right of your door opening, and pull the right side out first.
5. Vacuum the board off and blow the carbon out of the tubes, if there is any build-up.
6. Re-install the board and tubes, reversing the same method they were removed.

## SECTION XII: CREOSOTE

When wood is burned slowly, it produces tar and other organic vapors. These combine with moisture to form creosote. Creosote vapors condense in the relatively cool chimney flue of a slow-burning fire – as a result, creosote residue accumulates on the lining of the flue. If ignited, this creosote makes an extremely hot fire. The chimney should be inspected on a regular basis during the heating season, to determine if a creosote build-up has accumulated. If it has, the creosote should be removed to reduce the risk of chimney fire.

<p><b>WARNING: THINGS TO REMEMBER IN CASE OF A CHIMNEY FIRE:</b></p> <p><b>1. CLOSE DRAFT CONTROL</b>                      <b>2. CALL THE FIRE DEPARTMENT</b></p>
---

## WAYS TO PREVENT AND KEEP UNIT FREE OF CREOSOTE

1. Burn with the air control fully open for several minutes at numerous intervals throughout each day during the heating season, being careful not to over-fire the unit. This should remove the slight film of creosote that accumulates during low burn periods.
2. Burn the stove with the draft control fully open for approximately 20-30 minutes every time you apply fresh wood. This allows wood to achieve the charcoal stage faster, and burns wood vapors which might otherwise be deposited within the system.
3. **BURN ONLY SEASONED WOOD.** Avoid burning wet or green wood. Seasoned wood is wood that has been dried for at least one year.
4. A small, hot fire is preferable to a large, smoldering one that can deposit creosote within the system.
5. Establish a routine for fuel, wood burner and firing technique. Check daily for creosote build-up until experience shows you how often you need to clean to be safe. Keep in mind that the hotter the fire, the less creosote is deposited, and weekly cleanings may be necessary in milder weather, although monthly cleanings may be enough in the coldest months. Contact your local authority for information on how to handle a chimney fire, and have a clearly-understood plan to handle a chimney fire.

### Ash Removal and Disposal

Regularly inspect the ash build-up in your stove and remove as necessary. Ashes can be removed from the unit by shoveling them off the firebrick. Never remove red-hot ashes from the appliance; allow ashes to cool before removing. Ashes should be placed in a metal container with an airtight lid. Pending final disposal, the ashes should be placed on a non-combustible surface or on the ground, completely away from all combustible materials. The ashes should be retained in the closed container until all cinders have thoroughly cooled. It is essential with a masonry system that your flue be checked for creosote at least once per month.

## IMPORTANT: HELPFUL HINTS AND TIPS WORTH REVIEWING

1. **What is the correct way to start a fire?**
  - You will need small pieces of dry wood (kindling) and paper. Use only newspaper or paper that has not been coated or that has had materials glued or applied to it. Never use coated or colored paper (such as advertising flyers).
  - Open the door of the wood stove.
  - Crumple several pieces of paper, and place them in the center of the firebox, directly on the firebricks of the stove. Never use a grate to elevate the fire.
  - Place small pieces of dry wood (kindling) over the paper in the form of a “teepee.” This allows for good air circulation, which is important for good combustion.
  - Light the crumpled paper in two or three different locations. NOTE: It is important to heat the air in the stovepipe for draft to begin.
  - Fully open the air control of the wood stove, and close the door until it is just **slightly** open, allowing for air to be introduced into the firebox. Never leave the door fully open, as sparks from the kindling may occur, causing injury. As the fire begins to burn the kindling, some additional kindling may be needed to sustain the fire. **DO NOT** add more paper after the fire has started.

- Once the kindling has begun to burn, start adding some small pieces of seasoned, dry firewood. NOTE: Adding large pieces at the early stages will only serve to smother the fire. Continue adding small pieces of seasoned, dry firewood, keeping the door slightly open until each piece starts to ignite. Remember to always open the door slowly when placing wood into the fire.
  - Once the wood has started to ignite and the smoke has reduced, close the stove door fully. (Reduction of smoke is a good indication that the draft in the chimney has begun, and good combustion is now possible.) Larger pieces of seasoned, dry firewood can now be added when there is sufficient space in the firebox. Adjust the air control setting to your desired setting.
  - NOTE: The lower the air control setting, the longer the burn time of the firewood.
2. **What type of wood is best to use as firewood?**
    - Dry, seasoned hardwood should be used. Avoid green, unseasoned wood. Green wood, besides burning at only 60% of the fuel value of dry seasoned wood, will deposit creosote on the inside of the stove and along to inside of the chimney.
  3. **What does dry, seasoned wood mean, and what is considered to be hardwood?**
    - Wood that has been dried for a period of one year in a well-ventilated and sheltered area is considered dry, seasoned wood. Hardwoods generally come from slow-growth trees, such as Oak or Fir. Softwoods generally come from fast-growth trees, such as Pine or Spruce.
  4. **Will following the steps listed above result in a perfect fire every time?**
    - A good answer would be “most of the time.” There are many variables that can affect your rate of success when starting a fire, and experience will teach you how to deal with the variables. This section of the manual will cover some of the variables that can affect a fire, and time and patience will contribute to your ability to start a good fire consistently.
  5. **Why can't I get the fire lit?**
    - Damp or wet wood and poor draft are the main reasons for poor results when starting a fire. Remember to always use dry, seasoned wood for your fire. Even wood that has been dried (seasoned) for a long period of time will be difficult to light if it has gotten wet.
  6. **Why is there always a large quantity of thick black smoke in the firebox?**
    - A large quantity of thick black smoke in the firebox is a possible indication that you have poor draft.
  7. **Is it normal for soot to cover the glass at the beginning of a fire?**
    - This stove has been built with an air wash system that will help keep the glass clear when the firebox has reached a good operating temperature, and also has a good draft. Cold firebox temperature and poor draft cause soot to form on the glass. Once the firebox temperature and the draft increase, the soot should burn off.
  8. **What is “draft?”**
    - Draft is the ability of the chimney to exhaust draw by-products produced during the normal process of combustion.



## 9. What can cause a poor draft?

*There are several common factors that can contribute to poor draft:*

### A. Atmospheric Pressure and Air Supply

Atmospheric pressure affecting the draft from a chimney can be outside the home, inside the home, or both. Outside the home, a high-pressure (clear and cool) day generally creates a better draft in the chimney than a low-pressure (overcast and damp) day. Inside the home, household appliances, such as forced-air furnaces or clothes dryers, compete for air, often resulting in inadequate amounts of air available to fuel a fire and creating a condition known as negative pressure. Extreme conditions of negative pressure can cause the combustion by-products to be drawn from the chimney and into the house. This condition is commonly known as “down drafting.”

There are several factors that can affect the amount of air available in the home. Increased amounts of insulation, vinyl windows, extra caulking in various places and door seals can all keep heat in, but may also make a home too airtight. If you are in doubt as to whether or not there is sufficient air in your home for your stove, refrain from using those appliances known to consume air when possible, or open a door or a window to allow some air to enter the home.

### B. Environmental Conditions

High trees, a low-lying house location (such as in a valley), tall buildings or structures surrounding your house and even windy conditions can cause poor draft or down drafting.

### C. Cold Chimney Temperature

Avoid cold chimney temperatures by burning a hot fire for the first fifteen to forty minutes after building a fire, being careful not to over-fire. If any part of the chimney or parts of the stove start to glow, you are over-firing the stove. Where possible, install a temperature gauge on the chimney so temperature drops can be seen.

### D. Chimney Installation and Maintenance

Avoid using too many elbows or long horizontal runs. If in doubt, contact a chimney expert and/or chimney manufacturer for help. Clean your chimney, rain cap(s) and especially the spark arrester regularly, in order to prevent creosote build-up – which can significantly reduce chimney draw and possibly create a chimney fire.

## 10. Should I close or open the air control fully when shutting down the stove?

- When shutting down the stove, fully open the air control. This will allow chimney temperatures to remain as high as possible for as long as possible. Remember, cold chimney temperatures create creosote.

**NOTE: This section is intended as an aid and does not supersede any local, state or like requirements.**

**Check with officials or authorities having jurisdiction in your area.**

## **PARTS, ACCESSORIES AND OPTIONS LIST**

(Options and trim (*i.e. brass and nickel*) interchange for variety.)

### **REPLACEMENT PARTS**

AC-G17	DOOR GLASS KIT WITH GASKET (16 ½ " x 9 ¼ " x .197")
AC-GGK	DOOR GLASS GASKET KIT (gasket only, no glass)
AC-DGKNC	DOOR GASKET KIT (5/8" High-Density fiberglass rope gasket)
AC-PGK	COVER PLATE GASKET KIT
AC-SB	9" X 4" X 1 ¼" FIREBRICK (see Brick Layout diagram)
AC-SBN	9" X 4" X 1 ¼" FIREBRICK W/ .75 X .75 NOTCH (see Brick Layout diagram)
AC-SB2	4" X 2" X 1 ¼" FIREBRICK (see Brick Layout diagram)
AC-SBN	9" X 4" X 1 ¼" FIREBRICK W/ 1" X 3" NOTCH (see Brick Layout diagram)
AC-13BTF	FRONT BURNER TUBE
AC-13BTM	MIDDLE BURNER TUBE
AC-13BTR	REAR BURNER TUBE
AC-13CFB	CERAMIC FIBER BOARD
AC-SH	BRASS DOOR SPRING HANDLE
AC-SHN	NICKEL DOOR SPRING HANDLE
AC-SH4	BRASS AIR CONTROL SPRING HANDLE
AC-SH4N	NICKEL AIR CONTROL SPRING HANDLE
AC-MBSP	HI-TEMPERATURE BLACK PAINT

### **OPTIONS**

AC-13BA	ROOM AIR BLOWER
AC-108	BRASS ACCENT TRIM RING FOR DOOR
AC-108BN	NICKEL ACCENT TRIM RING FOR DOOR
AC-107	BRASS LIP TRIM
AC-107BN	NICKEL LIP TRIM
AC-105	BRASS LIP & BACKPLATE TRIM PACKAGE
CA-13G	GOLD PLATED DOOR

All parts can be ordered from your local dealer or from the factory at 1-800-516-3636.

**NOTE: Parts and accessories are also available on our web site: [www.englishstoves.com](http://www.englishstoves.com) .**

---

If you have any questions or problems contact the Technical support Department.

**TECHNICAL SUPPORT DEPARTMENT**  
**P.O. BOX 206**  
**MONROE, VA. 24574**

**Technical Questions/Technical support: (800-245-6489) (Fax: 434-929-4810)**

**[service@englishstoves.com](mailto:service@englishstoves.com)**

**Parts orders only: (800-516-3636)**



MODEL: 13-NC1/50-SNC113/50-TNC113  
 LISTED SOLID FUEL FIREPLACE INSERT  
 TESTED TO UL 1482

WHI- [REDACTED]

PREVENT HOUSE FIRES - INSTALL AND USE ONLY IN ACCORDANCE WITH THE OWNER'S MANUAL PROVIDED WITH THIS APPLIANCE. CONTACT LOCAL BUILDING OR FIRE OFFICIALS ABOUT RESTRICTIONS AND INSTALLATION INSPECTIONS IN YOUR AREA.

INSTALLATION REQUIREMENTS - DO NOT CONNECT THIS UNIT TO A CHIMNEY FLUE SERVING ANOTHER APPLIANCE. CONNECT TO A CODE-APPROVED MASONRY CHIMNEY OR LISTED FACTORY-BUILT FIREPLACE CHIMNEY WITH A DIRECT FLUE CONNECTOR INTO THE FIRST CHIMNEY LINER SECTION. PLACE NON-COMBUSTIBLE HEARTH PROTECTION WITH A MINIMUM R-VALUE OF 0.5, 16 INCHES TO THE FRONT AND 8 INCHES TO EACH SIDE OF THE FUEL OPENING. SEE OWNER'S MANUAL FOR ADDITIONAL INFORMATION.

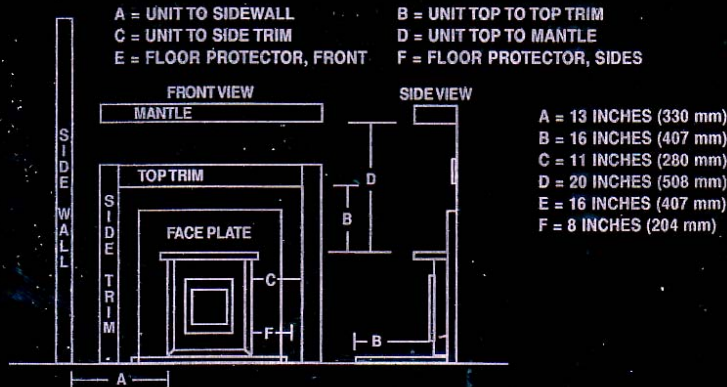

OPERATION REQUIREMENTS - FOR USE WITH SOLID WOOD FUEL ONLY. DO NOT OVERFIRE. IF HEATER OR CHIMNEY CONNECTOR GLOWS YOU ARE OVERFIRING. INSPECT AND CLEAN CHIMNEY FREQUENTLY. UNDER CERTAIN CONDITIONS OF USE CREOSOTE BUILDUP MAY OCCUR RAPIDLY. DO NOT USE GRATE OR ELEVATE FIRE. BURN WOOD FIRE DIRECTLY ON HEARTH. OPERATE WITH DOOR FULLY CLOSED.

U.S. ENVIRONMENTAL PROTECTION AGENCY, CERTIFIED UNDER 40 CFR 60.533(h). TO COMPLY WITH JULY 1990 PARTICULATE EMISSIONS STANDARDS.



**CAUTION:**

HOT WHILE IN OPERATION. DO NOT TOUCH. KEEP CHILDREN, CLOTHING, AND FURNITURE AWAY. CONTACT MAY CAUSE SKIN BURNS. SEE NAMEPLATE AND INSTRUCTIONS.

MANUFACTURED BY:  
 ENGLAND STOVE WORKS, INC.  
 P.O. BOX 206 MONROE, VA 24574

DATE OF MANUFACTURE: [REDACTED]

You may write your unit's Manufacture Date and Serial Number in the blank spaces on this sample tag, for future reference. This sample tag also shows the safety info. such as UL testing standard, etc. for your local officials, or anyone else who may need reference information.

Have this information on hand if you phone the factory or your dealer regarding this product.

Retain for your files:

Model Number \_\_\_\_\_

Date of Purchase \_\_\_\_\_

Date of Manufacture \_\_\_\_\_ Serial # \_\_\_\_\_

**LIMITED 5 YEAR WARRANTY**  
**FROM THE DATE OF PURCHASE TO THE ORIGINAL OWNER**

The manufacturer extends the following warranties:

**Five Year Period:**

1. Carbon steel and welded seams in the firebox are covered for 5 years against splitting.
2. The cast iron door, hasp and hinges are covered for 5 years against cracking.

**One Year Period:**

3. Component parts such as stainless steel tubes and brick retainers are covered for 1 year against cracking, breakage and welded seams from separating.
4. Ceramic fiber board baffle, electrical components, accessory items, glass and the painted surface are covered for 1 year from the date of purchase.

**Conditions and Exclusions:**

Damage from over-firing will void your warranty.

This warranty does not apply if damage occurs because of an accident, improper handling, improper installation, improper operation, abuse, or unauthorized repair made or attempted to be made.

The manufacturer is not liable for indirect, incidental, or consequential damages in connection with the product including any cost or expense providing substitute equipment or service during periods of malfunction or nonuse.

All liability for any consequential damage for breach of any written or implied warranty is disclaimed and excluded. Some states do not allow the exclusion or limitations of incidental or consequential damages, so the above may not apply to you.

**Procedure:**

Purchaser must give notice of claim of defect within the warranty period and pay transportation to and from a service center designated by the factory. The dealer from which the unit was purchased or the factory, at our option, will perform the warranty service.

**Other Rights:**

This warranty gives you specific legal rights, and you may also have other rights, which may vary from state to state.

**NOTE: THIS WARRANTY IS NULL AND VOID IF YOU DO NOT RETURN THE ATTACHED WARRANTY REGISTRATION WITH A COPY OF THE SALES RECEIPT WITHIN 30 DAYS FROM THE DATE OF PURCHASE. WARRANTY IS NOT TRANSFERABLE.**

# WARRANTY REGISTRATION for England's Stove Works

Purchased by (Name) \_\_\_\_\_

Address \_\_\_\_\_

City \_\_\_\_\_ State \_\_\_\_\_ Zip \_\_\_\_\_

Telephone \_\_\_\_\_

Email Address \_\_\_\_\_

## DEALER INFORMATION

Purchased From (Dealer) \_\_\_\_\_

Address \_\_\_\_\_

City \_\_\_\_\_ State \_\_\_\_\_ Zip \_\_\_\_\_

## UNIT INFORMATION

(Please be sure to refer to sticker on back of manual or box to complete this section)

Model Number \_\_\_\_\_ Purchase Date \_\_\_\_\_

Purchase Price \_\_\_\_\_

Serial Number \_\_\_\_\_ Mfg. Date \_\_\_\_\_

*How did you first hear about our product? (please check one)*

Word of Mouth       Burn Trailer Demonstration       Internet  
Other: \_\_\_\_\_

*Where did you receive information about our product? (please check one)*

Rec'd. info. via phone       Dealer (Name of dealer): \_\_\_\_\_  
 Internet      Other: \_\_\_\_\_

## IMPORTANT NOTICE

**THIS REGISTRATION INFORMATION MUST BE ON FILE FOR THIS WARRANTY TO BE VALID.  
PLEASE MAIL THIS INFORMATION WITHIN THIRTY (30) DAYS FROM THE DATE OF PURCHASE.**

Mail To:

England's Stove Works, Inc.  
Technical support Department  
P.O. Box 206  
Monroe, VA 24574

Or, Fax To:

(434) 929-4810 – 24 hours a day

Or, now available – Go online to complete your Warranty Registration!

Visit [www.englishstoves.com](http://www.englishstoves.com) if you prefer to register online.