



Opti-V™

The most unbelievable flame effect yet.

Opti-V Duet

VF5452L



Opti-V™ Duet uses unprecedented technology to render flames and sparks for a virtual fireplace experience like no other. The unique and patent protected design combines ultra realistic flickering flames with three dimensional LED logs that sporadically spark and crackle! The perfect blend of magic and realism - Opti-V™ is the most unbelievable flame effect yet.

120 Volts / 64 Watts / 0.53 Amps

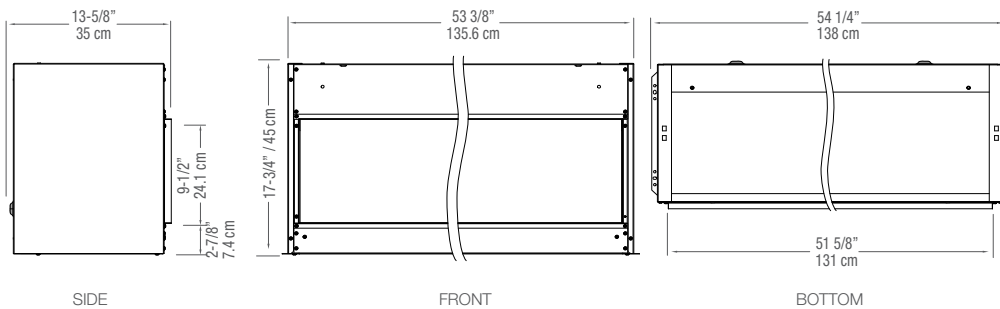

Features

- Flame**
A blend of three dimensional technology, artistry and craftsmanship create dazzling flickering flames that dance between the logs.
- Inner Glow Logs**
Embers glow from within the realistic, hand crafted logs.
- Sound**
Crackle of a real wood fire.
- Safe**
Front glass stays cool, making it safe to touch.
- Direct-wired**
Designed to be direct-wired to a 120/240V circuit for a seamless look.
- Year-round Enjoyment**
Enjoy the ambiance of the heatless flame year-round.
- Remote**
Includes a convenient remote with sound effect volume control.
- Economical**
Extremely low energy LED's costing less than 1¢ per day.
- Green**
The green alternative. No harmful particulates or emissions and 100% efficient.
- LED Technology**
Lasts more than 35 times longer and uses 10 times less energy than incandescent light bulbs.
- Reduces Liability**
Meets the strictest building codes; making it ideal for any commercial or residential installation.
- Maintenance Free**
Zero clearance for built-in applications; maintenance-free and operates for less than 1¢ per day.

* Note this product does not include a heater.

Model #	Description	Lbs / Kg	UPC	Wty.*	Carton Dimensions (WxHxD)		Cube	
					Inches	cm	ft³	m³
VF5452L	Opti-V™ Duet Built-in Virtual Fireplace	115 / 52.3	781052 092853	2 yr.	62-1/4 x 22-1/8 x 17-3/4	158 x 56 x 45	14.1	0.4

Specifications, finishes and dimensions are subject to change. *Limited warranty. ©2014 Dimplex North America Limited.

Dimplex North America Limited 1367 Industrial Rd., Cambridge ON, Canada, N1R 7G8 | 1-800-668-6663 | www.dimplex.com

Dimplex®

Better solutions through innovation