



CUSTOMER SERVICE CONTACT INFO

Phone: 888-686-7245(RAIL)
Fax: 888-686-7245 (RAIL)
Email: sales@stainlesscablerailing.com
Website: www.stainlesscablerailing.com

Address: 3315 NE 112th Ave #72/73, Vancouver, WA 98682

CABLEVIEW RAILING® INSTRUCTIONS

Choose **STAINLESS CABLE & RAILING™** for all your fittings and cablerail assemblies!

SIMPLE, STRONG

Table of Contents:

1. NECESSARY TOOLS
2. LAYOUT
3. CUT POSTS TO LENGTH
4. ASSEMBLE POSTS (DECK MOUNTED)
5. INSTALL POSTS
6. INSTALL TOP RAIL CORNERS
7. INSTALL TOP RAIL

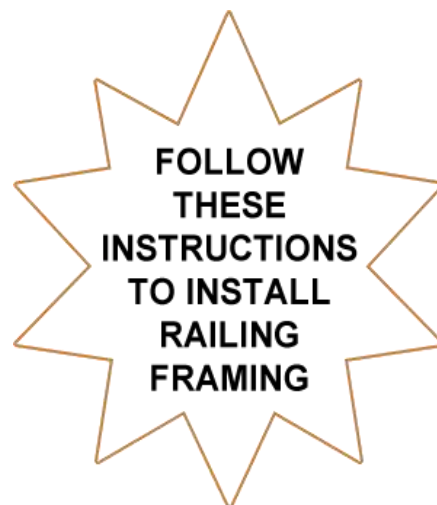

Just follow these simple steps:

1. NECESSARY TOOLS

1. MEASURING TAPE
2. CROSS CUT/CHOP SAW
3. DRILL
4. DRILL BIT INDEX
5. UNIVERSAL BIT HOLDER
6. SOCKET WRENCH SET
7. BLACK MARKER
8. CENTER PUNCH TOOL

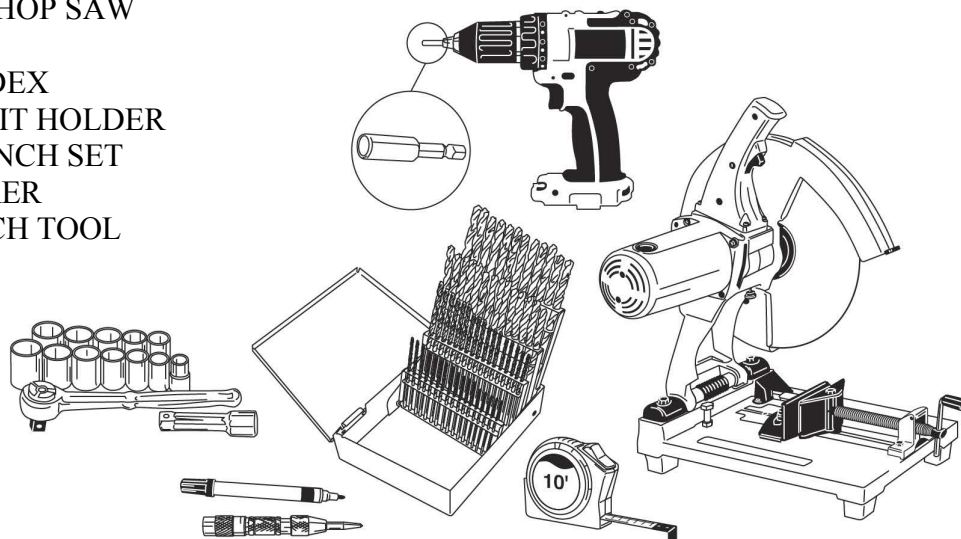

2. LAYOUT

- Determine where the cable will start and stop (ie; Sections). Reference the color-coded layout sheet (Fig 1) if it was included with these instructions.

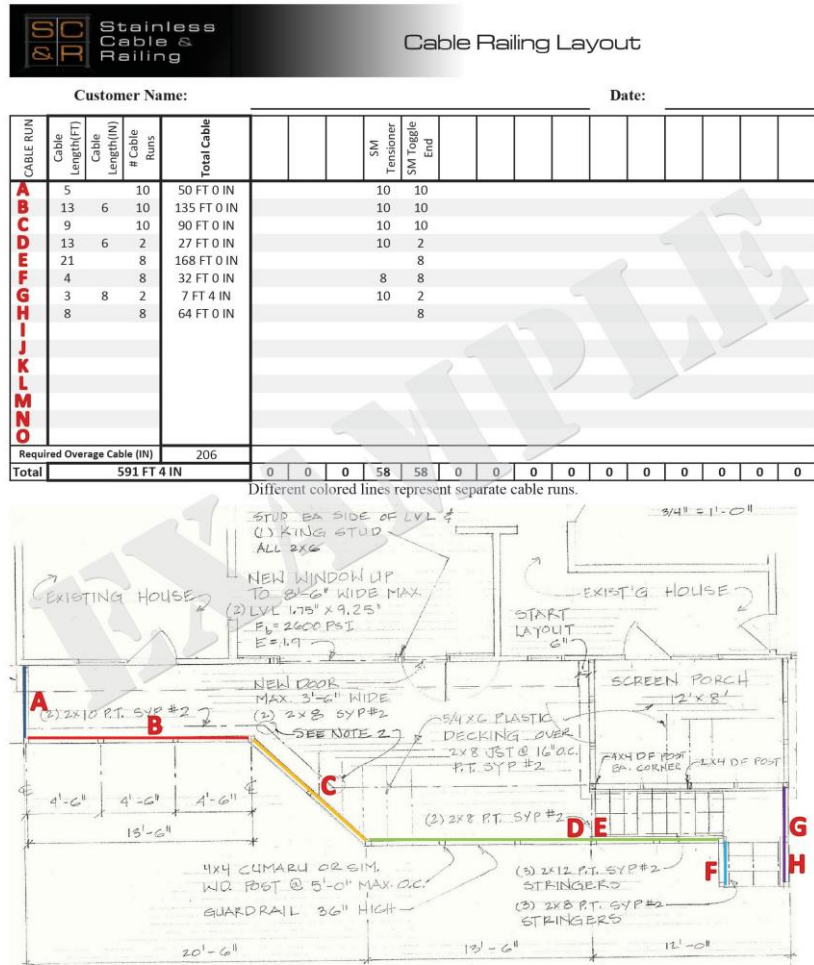

Fig 1

3. CUT POSTS TO LENGTH

Posts are shipped oversized to accommodate a variety of configurations and may need to be cut to length. If posts need to be cut, use a carbide tipped blade on a cross cut/chop saw (Fig 2). Cut posts to the appropriate height given your desired overall railing height including your top rail.

NOTE: For 36" residential height, there are 11 holes/cables.
For 42" residential/commercial height there are 13 holes/cables.

IMPORTANT: Cut the correct end of the post.
IMPORTANT: Before cutting stair posts, refer to 7E.

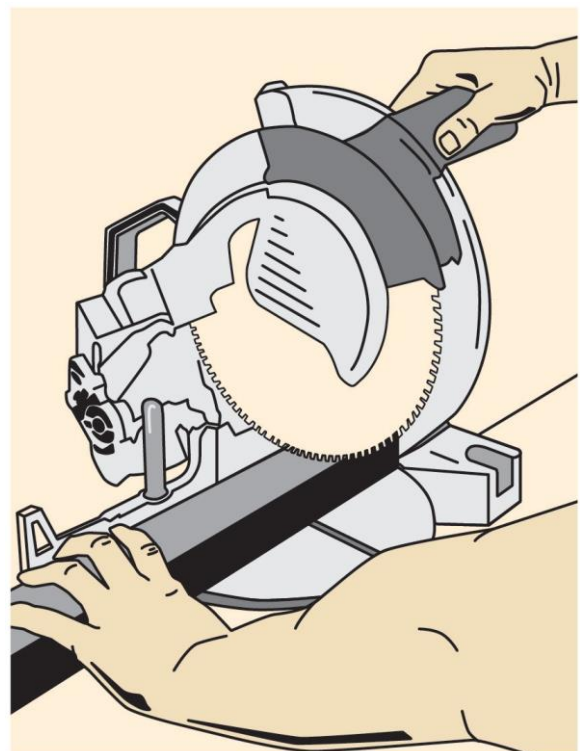

Fig 2

4. ASSEMBLE POSTS (DECK MOUNTED)

NOTE: IF USING FASCIA MOUNTED POSTS, SKIP THIS STEP AND GO TO STEP 5B.

Posts are shipped without the base plates installed. Use x4 1/4-20-2 1/2" Flathead Phillips T/F SS Screw and secure one aluminum base to each post. One rubber pad is used on the bottom of each post (Fig 3). Peel off adhesive backing and apply pad to the bottom of the post.

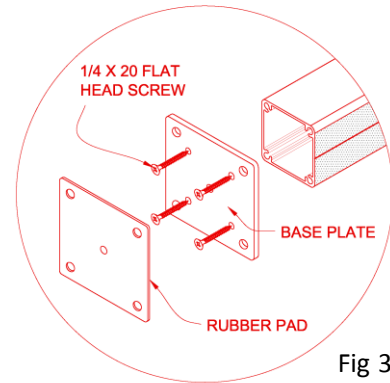

Fig 3

5. INSTALL POSTS

Refer to the layout (Fig 1) for proper post location. Pay particular attention to double (offset) post locations to be sure they will match up with the top rail corners.

5A DECK MOUNT

Anchor base plate with 3/8" bolts or lags. Insert bolt or lag through the optional Polypropylene Hinged Screw Cover for 3/8" x 4" Lag Screw/Washer for 3/8" Lag Screw (Fig 4) and tighten with a socket wrench. Ensure post is plumb. Some shimming and additional framing blocking may be necessary at each post (Fig 5.1 & 5.2).

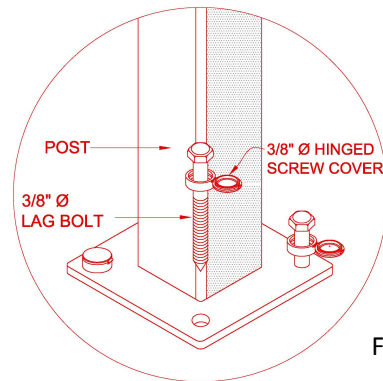

Fig 4

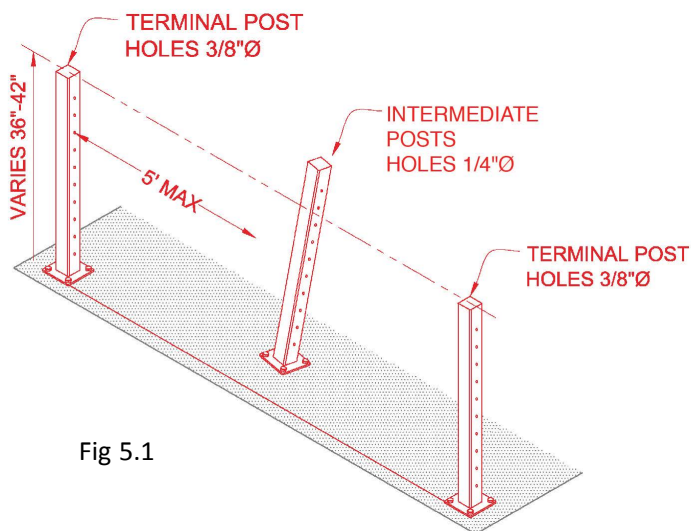

Fig 5.1

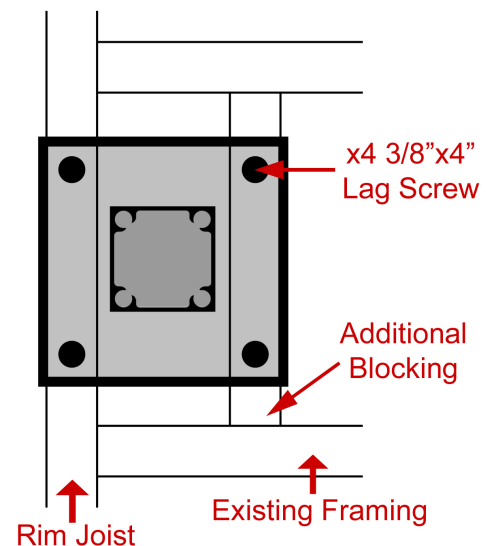

Fig 5.2

5B FASCIA MOUNT

Check your local building code requirements to determine approved mounting techniques. Fig 6 shows typical mounting options.

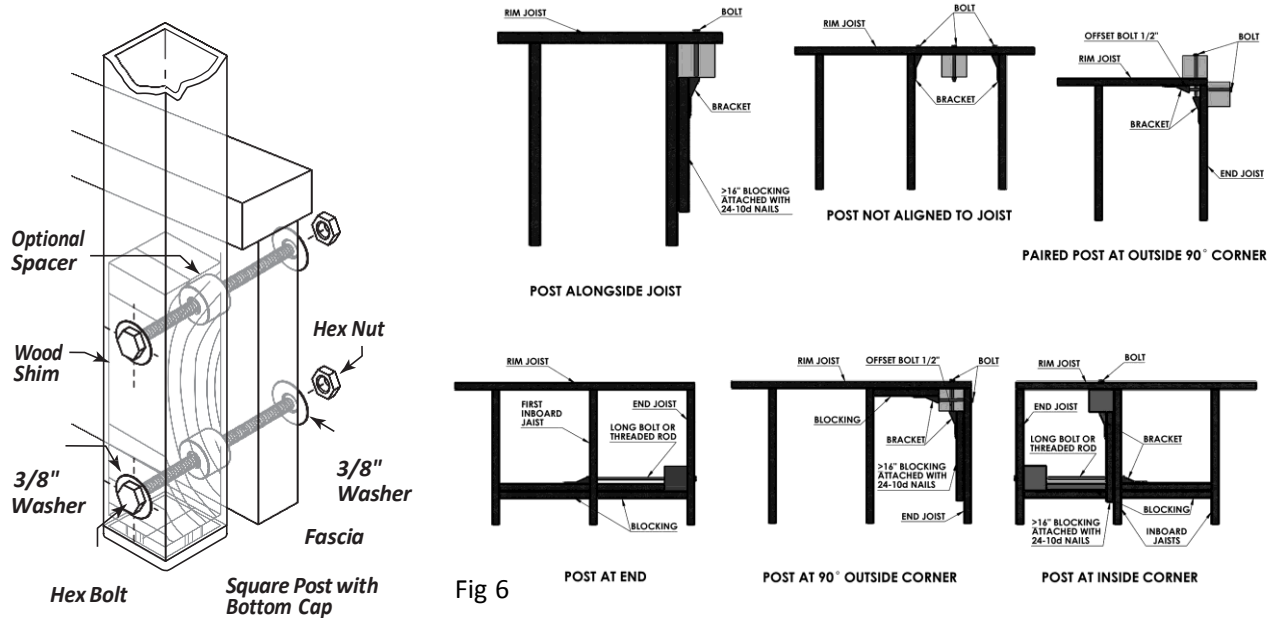

Fig 6

Fascia posts are usually shipped without the mounting holes pre-drilled to allow use in a variety of configurations. Mounting holes must be drilled whose size and location will vary depending on the mounting type selected. See Fig 7 & 8 for typical drilled hole detail.

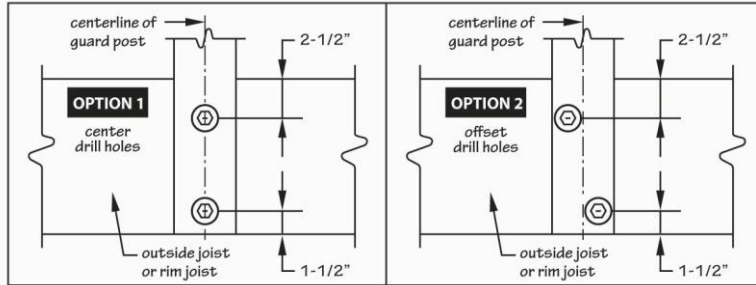

Fig 7

Hardware Size	Post Hole Size	Pilot Hole (Wood)
3/8" Bolt	13/32"	13/32"
3/8" Lag	13/32"	1/4"
1/2" Bolt	17/32"	17/32"
1/2" Lag	17/32"	11/32"

Fig 8

Prior to drilling fascia mounting holes, wood crush shims (customer supplied) must be cut and inserted into each post bottom. Crosscut 2 1/4" from 2" x 6" lumber to fit snugly inside each post bottom (Fig 6).

Use the layout (Fig 1) to determine post position. Additional blocking may be needed for strength and should be added at this time. Adjust mounting location up or down, as needed, keeping in mind the following:

- 1) Overall rail height. (36"-42")
- 2) Gap between the edge of the board and the first cable. <3">
- 3) Depending on the mounting hardware chosen, drill (2) appropriately sized holes through the base of each post. Use the following chart (Fig 7 & 8)

6. INSTALL TOP RAIL CORNERS

NOTE: IF USING **POST-TO-POST** RAIL, SKIP THIS STEP AND GO TO STEP 7E.

The **TOP RAIL CORNER** is designed to be re-cut in the field to match perfectly the position of the double (offset) posts and/or slightly off rail angles from the rail butting to it (Fig 9). All top rail joints are butt jointed over the center of a post using a **SPLICE FOR ALUMINUM TOP RAIL**. The **SPLICE** slides into the channel, joining rail/rail or the **TOP RAIL CORNER**/rail and is secured by screwing 4 **#8 x 3/4" PAN HEAD SCREW** through the flange on the underside and the **TOP RAIL SPLICE** (Fig 10). These screws will be completely hidden from view once the **TOP RAIL SNAP COVER** is installed (Fig 15). The **TOP RAIL CORNER** is secured with a bolt assembly (included) to the top of 2 posts by drilling through the **TOP RAIL CORNER** and the post with a **3/16"** drill bit. Maintain square and plumb of top rail and posts before pre-drilling and fasten with the included bolt hardware.

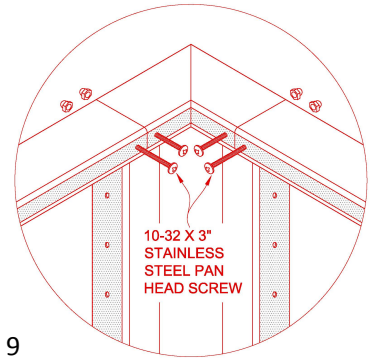

Fig 9

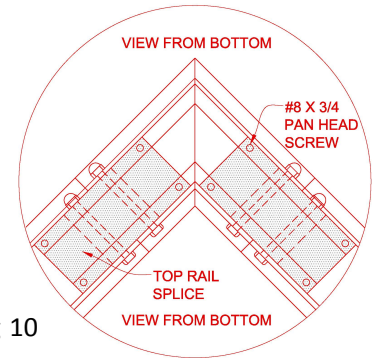

Fig 10

7. INSTALL TOP RAIL

7A Once the corners are installed, measure and cut top rail for the remainder of the railing system. Keep in mind that the top rail is used in the longest lengths practical since longer railings will incorporate more posts and strengthen the handrail. At the end of the railing, let your top rail run past the post about 1" (Fig 16). Also remember that any rail/rail butt joints must terminate at the center of a post (Fig 13). Pre-drill **9/64"** pilot holes through the outer face of the top rail into each post (Fig 11) and install x2 **#8x3/4"** Phillips Panhead Tek 410 SS Screw (included) for **INTERMEDIATE POSTS** and (x4) screws for the **TERMINAL POSTS**. Make sure the post is square to the top rail, by slightly shifting the top of the post left or right if necessary before pre-drilling and installing the screws. Where the top rail meets a **TOP RAIL CORNER**, substitute the screw for the bolt assembly that came included with the corner (Fig 10).

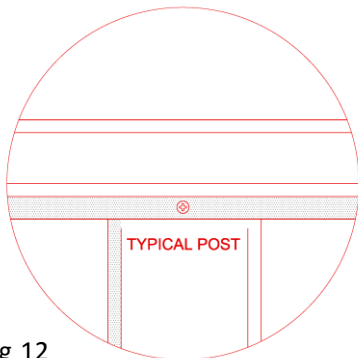
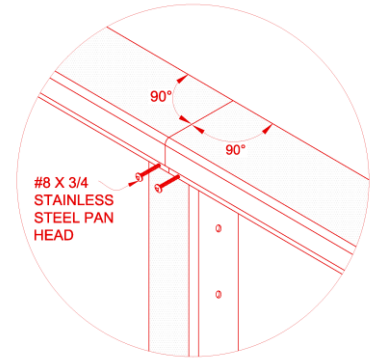

Fig 12

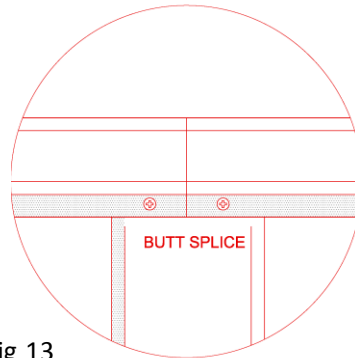

Fig 13

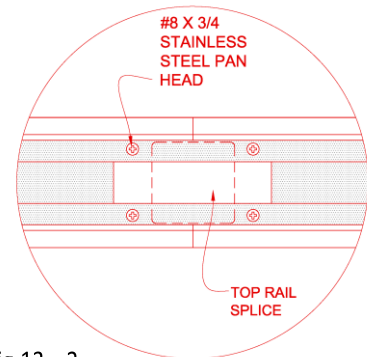

Fig 13---2

Top rail may run continuously from the horizontal to accommodate angles (Fig 14). Mitre cuts are required.

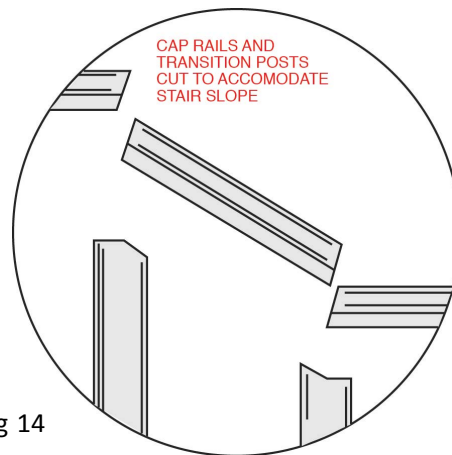

Fig 14

7B INSTALL SNAP COVER

Measure the distance between the posts and cut the TOP RAIL SNAP COVER. Install by snapping into the underside of the handrail (Fig 15). Short mitered pieces snap into place on the 90 DEGREE TOP RAIL CORNER. Make sure to cut the correct length and do not apply excessive force.

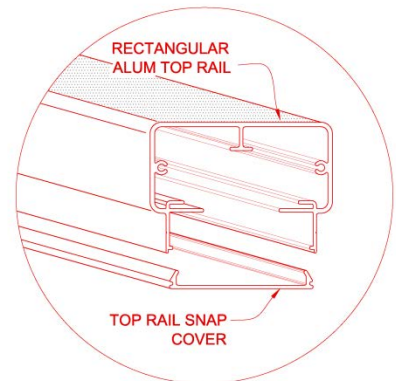

Fig 15

7C INSTALL TOP RAIL END

Using the supplied screws (x2 6-32 Type F Thread Cutting Pan Head), install the TOP RAIL END (Fig 16).

7D READY FOR CABLES

NOTE: Using grommets and/or PVC sleeves? Follow the steps in our "Grommet & PVC Sleeve Instructions" *before installing your cable*.

Refer to each assembly respective instructions for each cablerail assembly.

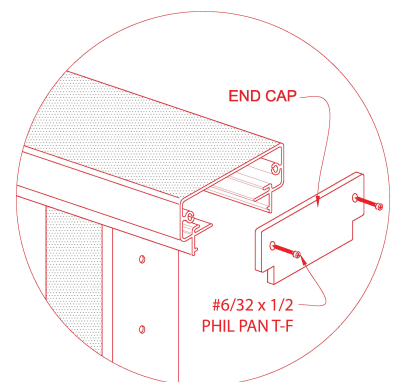

Fig 16

Need Assistance? Call 1-888-686-7245 (RAIL)

7E POST-TO-POST INSTALLATION (Not all designs will have this)

POST-TO-POST RAIL can be used in the following ways:

1. Inline Handrail/Support Rail
2. Stair Rail
3. Stand-Alone Handrail

1. **INLINE HANDRAIL/SUPPORT RAIL**

- 1.1 Must be installed sequentially starting from the first terminal post. Hold the mounting bracket centered against the inside face of the post, and 1/16" from to the top of the post (Fig 18). Mark with a felt tipped pen the two holes (Fig 17). Center punch the marked holes and drill pilot holes into post to accept x2 #10x3/4" Phillips Panhead Tek 410 SS Screw (included). Using these screws, attach mounting bracket to post (Fig 17). Repeat procedure for the next post. With the chop saw, cut the **POST TO POST RAIL** to length. At this time, loosen or remove anchors to allow the **POST TO POST RAIL** to be inserted over the brackets. Re-tighten the posts.

- 1.2 The **POST TO POST RAIL** is then screwed into place by pre-drilling 9/64" pilot holes through the rail into the bracket and securing with x2 #8x3/4" Phillips Panhead Tek 410 SS Screw (Fig 19). A variety of customer supplied top rail wood works well in this application. Usually drilling up from the bottom through the POST TO POST RAIL and screwing into the wood works the best (Fig 20).

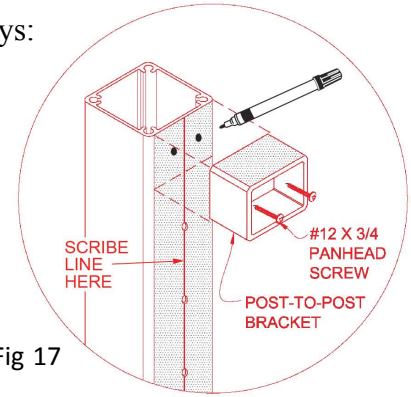

Fig 17

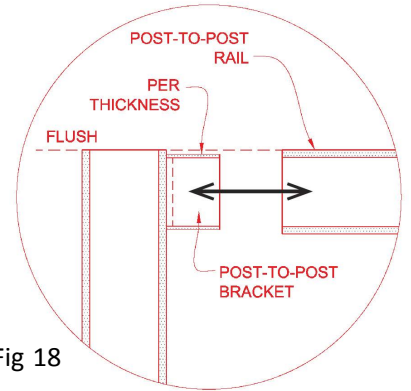

Fig 18

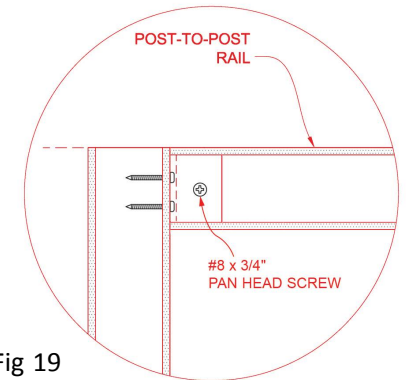

Fig 19

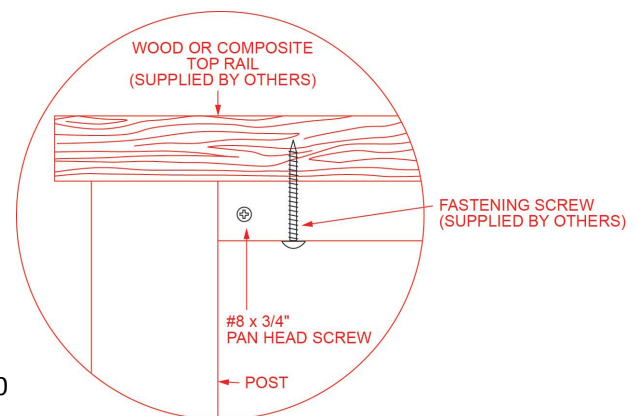

Fig 20

1.3 **90 DEGREE POST-TO-POST INSTRUCTIONS**

Determine the proper placement of the plastic bracket vertically on the post. This is based on where you plan to attach the Post-To-Post rail.

Insert # 8 x 1 ¼ Tech Screw, hold in position, pushing hard on the corner of the bracket (Fig 21).

Using the proper size Philip driver, power turn each screw until it drills into the post and tightens. (Note: If this proves difficult to drill with the Tech Screws, turn them a few times to mark the locations and drill with 1/8" drill bit.)

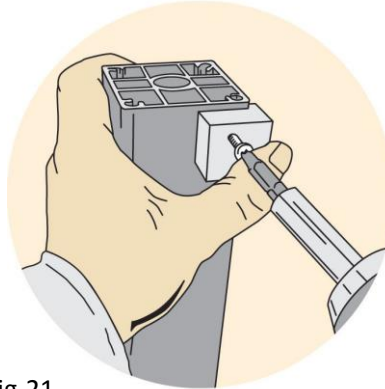

Fig 21

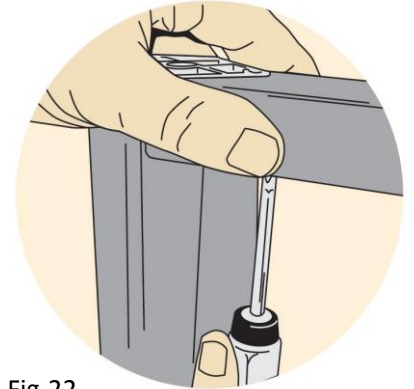

Fig 22

1.4 **135 DEGREE POST-TO-POST INSTRUCTIONS**

Determine proper placement of plastic bracket vertically on the post.

Line up the black line on the bracket with the scribe line on the post (Fig 23).

Insert a # 8 x ¾ Tech Screw in the hole on the short side of the bracket and a # 8 1 ¼ Tech Screw in the hole on the long side of the bracket. Turn each a few times to mark the location on the post.

Use 1/8" drill bit to drill through the side of the post at those marks.

Attach bracket with screws using a long Philips driver.

Install corner Post-To-Post piece (cut at proper angle and length) over bracket. Line up rail so it is flush with sides of post.

On the underside of the corner piece, drill through the METAL ONLY with an 11/64" drill bit, exposing the plastic bracket inside (Fig 24).

Drill a ½" pilot hole into the plastic bracket with a 1/8" drill bit.

Using a Philips screwdriver, hand screw in # 8 x ½" screw.

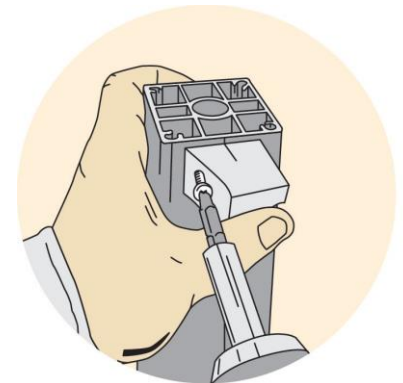

Fig 23

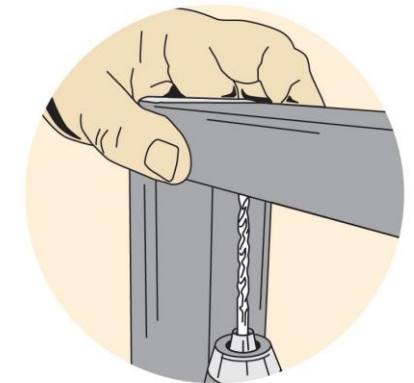

Fig 24

2. STAIR RAIL

2:1 Install top and bottom stair posts first. Before cutting stair posts to length, keep the following in mind:

- Post-To-Post stair handrail must run continuously between the posts at the head and base of the stairs.
- Posts at the top and bottom of the stairs will be longer than the intermediate posts. (See 2:7)
- Finished handrail height must be between 36" (max) and 34" (min).
- Post-To-Post hand rail is often used as a standalone stair hand rail (Fig 25).

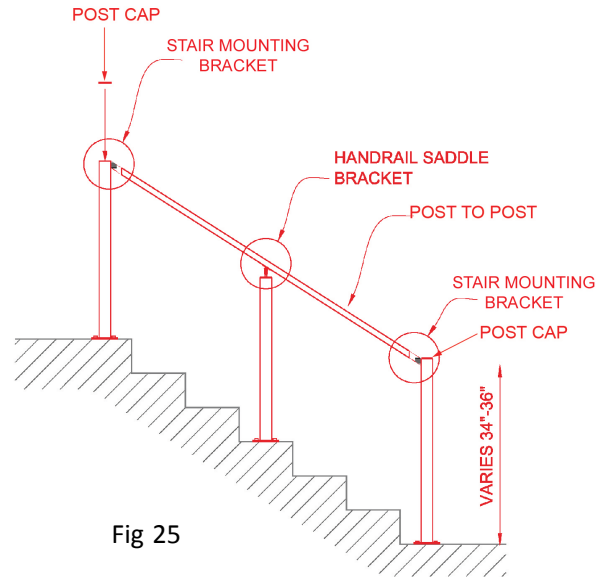

Fig 25

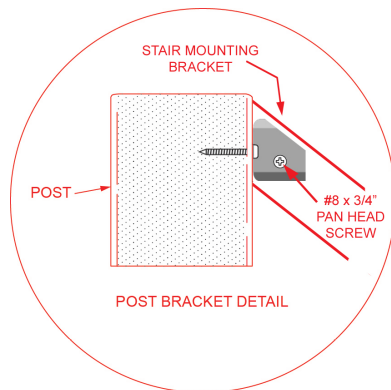

Fig 26

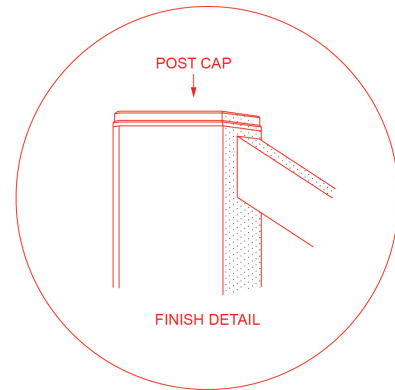

Fig 27

- Post-To-Post hand rail can also be combined with a wood top rail (Fig 28).

2:2 Determine mounting position for the Stair-Mounting Bracket which will be influenced by stair pitch and the desired position of the Post-To-Post rail (Fig 26).

2:3 Using the procedure previously described, secure bracket onto post using the supplied screws.

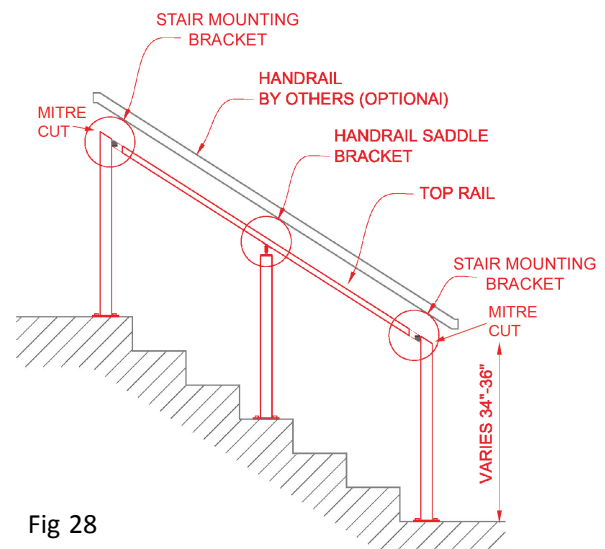

Fig 28

2:4 Install Post Caps with silicone applied to the inside cavity of the post, if using as a standard handrail (Fig 27).

2:5 Secure each Handrail Saddle Bracket onto each intermediate post and hold in position to mark the holes that will connect the bracket to the underside of the Post-To-Post (Fig 29 & 30).

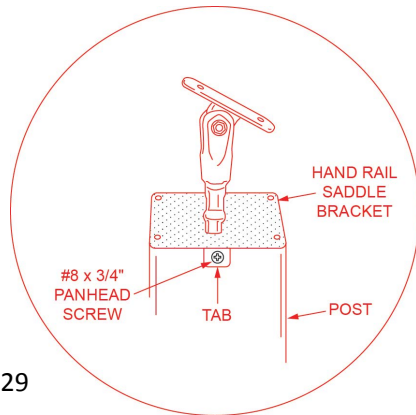

Fig 29

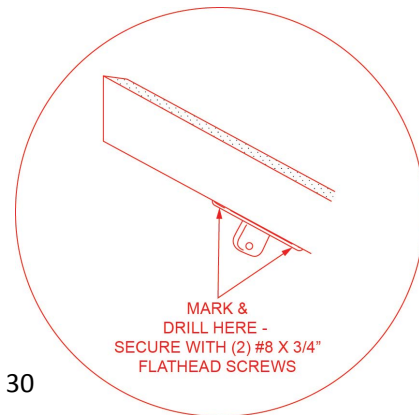

Fig 30

Unscrew and disassemble the upper portion of the bracket to make it easier to mark and drill holes. Drill 9/64" pilot holes in marked locations. Using the two screws that are provided, screw the bracket into place (Fig 30). Reassemble to finish (Fig 25).

3. STAND-ALONE HANDRAIL

Use this handrail along walls or attach to your posts as a separate graspable handrail to increase guided support.

3:1 Each handrail Assembly includes:

1ea Post-to-Post
(length varies)

2ea Handrail Wall Returns

Handrail Brackets
(quantity varies)

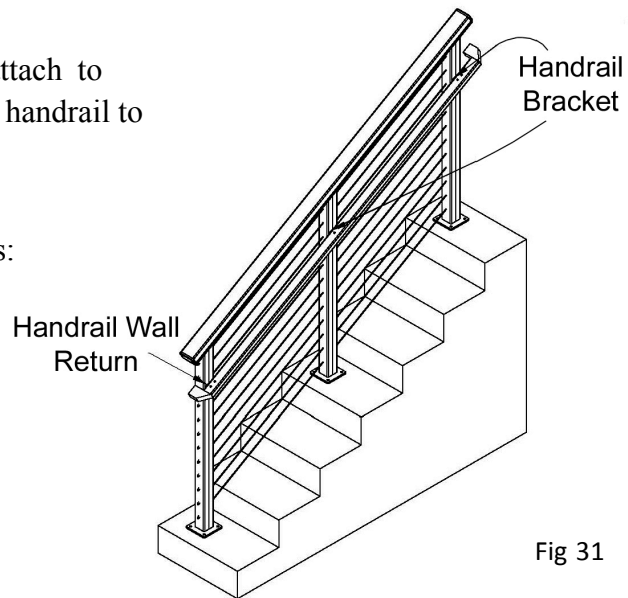

Fig 31

POST-TO-POST
STAND ALONE HAND RAIL