

MWMH weighing modules

Series of professional electromagnetic modules of high resolution guarantees highly precise and fast measurement.



MWMH IP69K



MWMH IP65



Easy access to the most functional interfaces

Features

Vast Max Capacity Range

Magnetolectric weighing modules MWMH are intended for mass measurement ranging from 1kg to 10kg. Minimum readability of 0.01g guarantees amazing accuracy for your measurement.

Protection Against Challenging Conditions

Hermetic versions of modules feature stainless steel housing with IP65 and IP69K. This allows operation even in the most challenging conditions. Mechanical design lacks sharp edges and gaps which ensures adherence to HACCP, GMP and FDA standards for safety and quality of operation.

Fast and Precise Measurement

High measurement accuracy with $sd=1d^*$ guarantees both readout of real weighing results and repeatability of indications. Cutting-edge design solutions provide fast measurement which is an asset allowing to install the module on automated production lines. Intended for fast and dynamic measuring processes the weighing module's converter throughput is 3200 meas./s**.

Cooperation with terminals

Connecting the module to a multifunctional weighing terminal expands communication interfaces range and increases usage in industrial applications.

Technical Specifications

	MWMH 100-1	MWMH 200-1	MWMH 500-1	MWMH 1000-1
Maximum capacity [Max]	1000 g	2000 g	5000 g	10000 g
Input load (preload range)	6 – 9 kg	4 – 7 kg	4 – 7 kg	4 – 7 kg
Minimum capacity	2 g	4 g	10 g	20 g
Readability [d] *	0.1 g	0.2 g	0.5 g	1 g
Max readability for non-verified module	0.01 g	0.02 g	0.1 g	0.1 g
Verification scale interval [e]	0.1 g	0.2 g	0.5 g	1 g
Tare range	–1000 g	–2000 g	–5000 g	–10000 g
Repeatability**	0.01 g	0.1 g	0.1 g	0.1 g
Sensitivity temperature drift***	$2 \times 10^{-6} / ^\circ\text{C} \times \text{Rt}$	$2 \times 10^{-6} / ^\circ\text{C} \times \text{Rt}$	$2 \times 10^{-6} / ^\circ\text{C} \times \text{Rt}$	$2 \times 10^{-6} / ^\circ\text{C} \times \text{Rt}$
Adjustment	external	external	external	external
Verification	Yes	Yes	Yes	Yes
OIML Class	III	III	III	III
Construction material	stainless steel	stainless steel	stainless steel	stainless steel
Display	—	—	—	—
Protection class	IP65 - Binder connectors	IP65 - Binder connectors	IP65 - Binder connectors	IP65 - Binder connectors
RS 232	1 - Binder connector	1 - Binder connector	1 - Binder connector	1 - Binder connector
Ethernet	1 - Binder connector	1 - Binder connector	1 - Binder connector	1 - Binder connector
IN/OUT	2 × IN, 2 × OUT	2 × IN, 2 × OUT	2 × IN, 2 × OUT	2 × IN, 2 × OUT
PROFINET module****	1 × RJ45 socket	1 × RJ45 socket	1 × RJ45 socket	1 × RJ45 socket
PROFIBUS module****	1 - Binder connector	1 - Binder connector	1 - Binder connector	1 - Binder connector
Signal cable on a weighing pan	—	—	—	—
Communication protocol	ASCII Text / Modbus RTU / TCP	ASCII Text / Modbus RTU / TCP	ASCII Text / Modbus RTU / TCP	ASCII Text / Modbus RTU / TCP
Power supply	12 ÷ 24 V DC	12 ÷ 24 V DC	12 ÷ 24 V DC	12 ÷ 24 V DC
Power consumption	5 W	5 W	5 W	5 W
Operating temperature	+10 ÷ +40 °C	+10 ÷ +40 °C	+10 ÷ +40 °C	+10 ÷ +40 °C
Atmospheric humidity*****	15 ÷ 80%	15 ÷ 80%	15 ÷ 80%	15 ÷ 80%
Transport and storage temperature	–20 ÷ +50 °C	–20 ÷ +50 °C	–20 ÷ +50 °C	–20 ÷ +50 °C
Weighing pan dimensions	212 × 174 mm	212 × 174 mm	212 × 174 mm	212 × 174 mm
Weighing device dimensions	344 × 224 × 164 mm	344 × 224 × 164 mm	344 × 224 × 164 mm	344 × 224 × 164 mm
Net weight	12.4 kg	12.4 kg	12.4 kg	12.4 kg
Gross weight	15 kg	15 kg	15 kg	15 kg
Packaging dimensions	580 × 413 × 360 mm	580 × 413 × 360 mm	580 × 413 × 360 mm	580 × 413 × 360 mm

Rt net weight

* for modules with verification

** repeatability is expressed as a standard deviation from 10 weighing cycles

*** parameter determined in the following temperature range: +15 ÷ +35 °C

**** interface installed interchangeably with Ethernet, IN/OUT, RS 485

***** non-condensing conditions

Technical Specifications

	MWMH 100-2	MWMH 200-2	MWMH 500-2	MWMH 1000-2
Maximum capacity [Max]	1000 g	2000 g	5000 g	10000 g
Input load (preload range)	6 – 9 kg	4 – 7 kg	4 – 7 kg	4 – 7 kg
Minimum capacity	2 g	4 g	10 g	20 g
Readability [d] *	0.1 g	0.2 g	0.5 g	1 g
Max readability for non-verified module	0.01 g	0.02 g	0.1 g	0.1 g
Verification scale interval [e]	0.1 g	0.2 g	0.5 g	1 g
Tare range	–1000 g	–2000 g	–5000 g	–10000 g
Repeatability**	0.01 g	0.1 g	0.1 g	0.1 g
Sensitivity temperature drift***	$2 \times 10^{-6} / ^\circ\text{C} \times \text{Rt}$	$2 \times 10^{-6} / ^\circ\text{C} \times \text{Rt}$	$2 \times 10^{-6} / ^\circ\text{C} \times \text{Rt}$	$2 \times 10^{-6} / ^\circ\text{C} \times \text{Rt}$
Adjustment	external	external	external	external
Verification	Yes	Yes	Yes	Yes
OIML Class	III	III	III	III
Construction material	stainless steel	stainless steel	stainless steel	stainless steel
Display	—	—	—	—
Protection class	IP65 - Binder connectors	IP65 - Binder connectors	IP65 - Binder connectors	IP65 - Binder connectors
RS 232	1 - Binder connector	1 - Binder connector	1 - Binder connector	1 - Binder connector
Ethernet	1 - Binder connector	1 - Binder connector	1 - Binder connector	1 - Binder connector
IN/OUT	2 × IN, 2 × OUT	2 × IN, 2 × OUT	2 × IN, 2 × OUT	2 × IN, 2 × OUT
PROFINET module****	1 × RJ45 socket	1 × RJ45 socket	1 × RJ45 socket	1 × RJ45 socket
PROFIBUS module****	1 - Binder connector	1 - Binder connector	1 - Binder connector	1 - Binder connector
Signal cable on a weighing pan	yes - Binder connector	yes - Binder connector	yes - Binder connector	yes - Binder connector
Communication protocol	ASCII Text / Modbus RTU / TCP	ASCII Text / Modbus RTU / TCP	ASCII Text / Modbus RTU / TCP	ASCII Text / Modbus RTU / TCP
Power supply	12 ÷ 24 V DC	12 ÷ 24 V DC	12 ÷ 24 V DC	12 ÷ 24 V DC
Power consumption	5 W	5 W	5 W	5 W
Operating temperature	+10 ÷ +40 °C	+10 ÷ +40 °C	+10 ÷ +40 °C	+10 ÷ +40 °C
Atmospheric humidity*****	15 ÷ 80%	15 ÷ 80%	15 ÷ 80%	15 ÷ 80%
Transport and storage temperature	–20 ÷ +50 °C	–20 ÷ +50 °C	–20 ÷ +50 °C	–20 ÷ +50 °C
Weighing pan dimensions	212 × 174 mm	212 × 174 mm	212 × 174 mm	212 × 174 mm
Weighing device dimensions	344 × 224 × 164 mm	344 × 224 × 164 mm	344 × 224 × 164 mm	344 × 224 × 164 mm
Net weight	12.4 kg	12.4 kg	12.4 kg	12.4 kg
Gross weight	15 kg	15 kg	15 kg	15 kg
Packaging dimensions	580 × 413 × 360 mm	580 × 413 × 360 mm	580 × 413 × 360 mm	580 × 413 × 360 mm

Rt net weight
 * for modules with verification
 ** repeatability is expressed as a standard deviation from 10 weighing cycles
 *** parameter determined in the following temperature range: +15 ÷ +35 °C
 **** interface installed interchangeably with Ethernet, IN/OUT, RS 485
 ***** non-condensing conditions

Technical Specifications

	MWMH 100-3	MWMH 200-3	MWMH 500-3	MWMH 1000-3
Maximum capacity [Max]	1000 g	2000 g	5000 g	10000 g
Input load (preload range)	6 – 9 kg	4 – 7 kg	4 – 7 kg	4 – 7 kg
Minimum capacity	2 g	4 g	10 g	20 g
Readability [d] *	0.1 g	0.2 g	0.5 g	1 g
Max readability for non-verified module	0.1 g	0.1 g	0.1 g	0.1 g
Verification scale interval [e]	0.1 g	0.2 g	0.5 g	1 g
Tare range	–1000 g	–2000 g	–5000 g	–10000 g
Repeatability**	0.01 g	0.1 g	0.1 g	0.1 g
Sensitivity temperature drift***	$2 \times 10^{-6} / ^\circ\text{C} \times \text{Rt}$	$2 \times 10^{-6} / ^\circ\text{C} \times \text{Rt}$	$2 \times 10^{-6} / ^\circ\text{C} \times \text{Rt}$	$2 \times 10^{-6} / ^\circ\text{C} \times \text{Rt}$
Adjustment	external	external	external	external
Verification	Yes	Yes	Yes	Yes
OIML Class	III	III	III	III
Construction material	stainless steel	stainless steel	stainless steel	stainless steel
Display	—	—	—	—
Protection class	IP69K - cable glands	IP69K - cable glands	IP69K - cable glands	IP69K - cable glands
RS 232	1 - cable gland	1 - cable gland	1 - cable gland	1 - cable gland
Ethernet	1 - cable gland	1 - cable gland	1 - cable gland	1 - cable gland
IN/OUT	2 × IN, 2 × OUT	2 × IN, 2 × OUT	2 × IN, 2 × OUT	2 × IN, 2 × OUT
PROFINET module****	1 × RJ45 socket	1 × RJ45 socket	1 × RJ45 socket	1 × RJ45 socket
PROFIBUS module****	1 - cable gland	1 - cable gland	1 - cable gland	1 - cable gland
Signal cable on a weighing pan	—	—	—	—
Communication protocol	ASCII Text / Modbus RTU / TCP	ASCII Text / Modbus RTU / TCP	ASCII Text / Modbus RTU / TCP	ASCII Text / Modbus RTU / TCP
Power supply	12 ÷ 24 V DC	12 ÷ 24 V DC	12 ÷ 24 V DC	12 ÷ 24 V DC
Power consumption	5 W	5 W	5 W	5 W
Operating temperature	+10 ÷ +40 °C	+10 ÷ +40 °C	+10 ÷ +40 °C	+10 ÷ +40 °C
Atmospheric humidity*****	15 ÷ 80%	15 ÷ 80%	15 ÷ 80%	15 ÷ 80%
Transport and storage temperature	–20 ÷ +50 °C	–20 ÷ +50 °C	–20 ÷ +50 °C	–20 ÷ +50 °C
Weighing pan dimensions	212 × 174 mm	212 × 174 mm	212 × 174 mm	212 × 174 mm
Weighing device dimensions	344 × 224 × 164 mm	344 × 224 × 164 mm	344 × 224 × 164 mm	344 × 224 × 164 mm
Net weight	12.4 kg	12.4 kg	12.4 kg	12.4 kg
Gross weight	15 kg	15 kg	15 kg	15 kg
Packaging dimensions	580 × 413 × 360 mm	580 × 413 × 360 mm	580 × 413 × 360 mm	580 × 413 × 360 mm

Rt net weight
 * for modules with verification
 ** repeatability is expressed as a standard deviation from 10 weighing cycles
 *** parameter determined in the following temperature range: +15 ÷ +35 °C
 **** interface installed interchangeably with Ethernet, IN/OUT, RS 485
 ***** non-condensing conditions

Technical Specifications

	MWMH 100-4	MWMH 200-4	MWMH 500-4	MWMH 1000-4
Maximum capacity [Max]	1000 g	2000 g	5000 g	10000 g
Input load (preload range)	6 – 9 kg	4 – 7 kg	4 – 7 kg	4 – 7 kg
Minimum capacity	2 g	4 g	10 g	20 g
Readability [d] *	0.1 g	0.2 g	0.5 g	1 g
Max readability for non-verified module	0.1 g	0.1 g	0.1 g	0.1 g
Verification scale interval [e]	0.1 g	0.2 g	0.5 g	1 g
Tare range	–1000 g	–2000 g	–5000 g	–10000 g
Repeatability**	0.01 g	0.1 g	0.1 g	0.1 g
Sensitivity temperature drift***	$2 \times 10^{-6} / ^\circ\text{C} \times R_t$	$2 \times 10^{-6} / ^\circ\text{C} \times R_t$	$2 \times 10^{-6} / ^\circ\text{C} \times R_t$	$2 \times 10^{-6} / ^\circ\text{C} \times R_t$
Adjustment	external	external	external	external
Verification	Yes	Yes	Yes	Yes
OIML Class	III	III	III	III
Construction material	stainless steel	stainless steel	stainless steel	stainless steel
Display	—	—	—	—
Protection class	IP69K - cable glands	IP69K - cable glands	IP69K - cable glands	IP69K - cable glands
RS 232	1 - cable gland	1 - cable gland	1 - cable gland	1 - cable gland
Ethernet	1 - cable gland	1 - cable gland	1 - cable gland	1 - cable gland
IN/OUT	2 × IN, 2 × OUT	2 × IN, 2 × OUT	2 × IN, 2 × OUT	2 × IN, 2 × OUT
PROFINET module****	1 × RJ45 socket	1 × RJ45 socket	1 × RJ45 socket	1 × RJ45 socket
PROFIBUS module****	1 - cable gland	1 - cable gland	1 - cable gland	1 - cable gland
Signal cable on a weighing pan	yes - cable gland	yes - cable gland	yes - cable gland	yes - cable gland
Communication protocol	ASCII Text / Modbus RTU / TCP	ASCII Text / Modbus RTU / TCP	ASCII Text / Modbus RTU / TCP	ASCII Text / Modbus RTU / TCP
Power supply	12 ÷ 24 V DC	12 ÷ 24 V DC	12 ÷ 24 V DC	12 ÷ 24 V DC
Power consumption	5 W	5 W	5 W	5 W
Operating temperature	+10 ÷ +40 °C	+10 ÷ +40 °C	+10 ÷ +40 °C	+10 ÷ +40 °C
Atmospheric humidity*****	15 ÷ 80%	15 ÷ 80%	15 ÷ 80%	15 ÷ 80%
Transport and storage temperature	–20 ÷ +50 °C	–20 ÷ +50 °C	–20 ÷ +50 °C	–20 ÷ +50 °C
Weighing pan dimensions	212 × 174 mm	212 × 174 mm	212 × 174 mm	212 × 174 mm
Weighing device dimensions	344 × 224 × 164 mm	344 × 224 × 164 mm	344 × 224 × 164 mm	344 × 224 × 164 mm
Net weight	12.4 kg	12.4 kg	12.4 kg	12.4 kg
Gross weight	15 kg	15 kg	15 kg	15 kg
Packaging dimensions	580 × 413 × 360 mm	580 × 413 × 360 mm	580 × 413 × 360 mm	580 × 413 × 360 mm

Rt net weight
 * for modules with verification
 ** repeatability is expressed as a standard deviation from 10 weighing cycles
 *** parameter determined in the following temperature range: +15 ÷ +35 °C
 **** interface installed interchangeably with Ethernet, IN/OUT, RS 485
 ***** non-condensing conditions

Dimensions

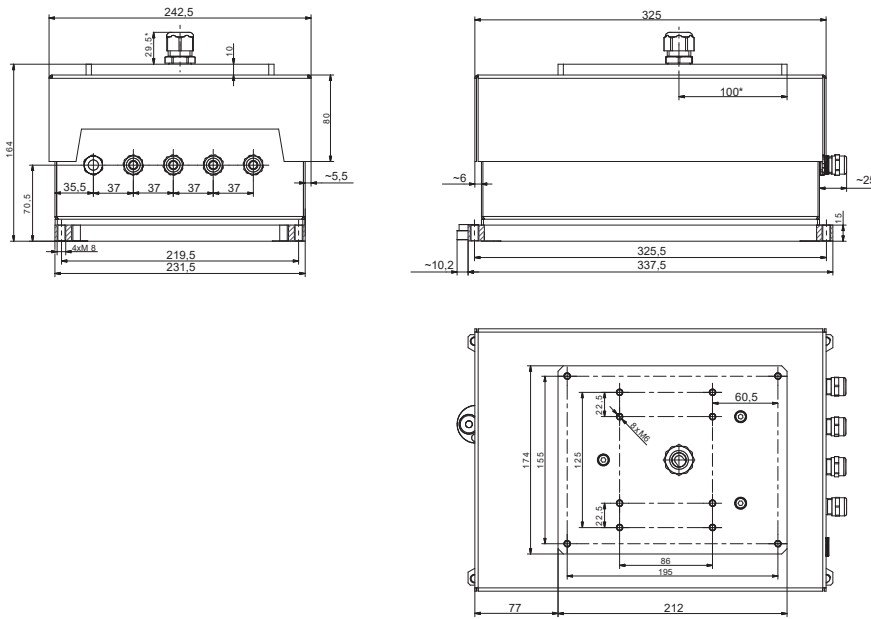

MWMH IP 69K

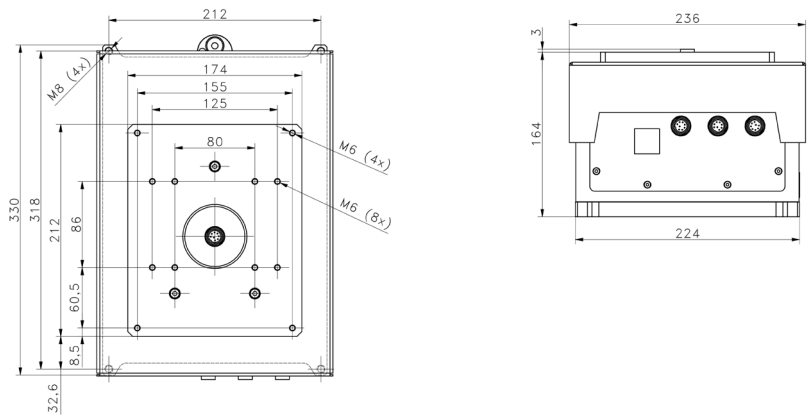

MWMH IP 65

Dedicated Software

MWMH-Manager

- option of adjustment of HRP platforms and MWSH, MWLH and MWMH modules
- option of readout of mass from HRP platforms and modules using the computer
- option of taring and zeroing HRP platforms and modules using the computer
- option of setting weighing filters for HRP platforms and modules

RADWAG Development Studio

- presentation of functions (and subfunctions) of communication protocol (Common Communication Protocol)
- possibility of connection with weighing equipment on which each function is carried out,
- library with mass control, contained within the development environment
- complete documentation of the communication protocol
- set of user manuals for different solutions addressed for programmers employed in companies using RADWAG-manufactured weighing equipment

LabView Driver

- operation of RADWAG balances in LabView environment

RADWAG Connect

- establishing communication with all balances, scales and weighing modules using Common Communication Protocol
- communication via local network,
- support of basic functions
- auto searching for devices
- connecting with few devices simultaneously, swapping between them
- clear list of connected platforms
- record of measurements in the program
- export of carried out measurements to CSV file
- work performed using freely selected device with Windows 10 operating system

RAD KEY

- Establishing cooperation between a weighing instrument and a computer