

Caché®

Hidden Faucet Aerator - 1.5 gpm

Flow Restricted Regular Size

Features and Benefits

- Threads directly (and disappears) into the faucet spout.
- Helps facilitate spout manufacturing and reduce cost.
- Vandal proof by design.
- Built on Cascade® or Perlator® design.



Certification

ANSI/NSF 61
WaterSense listed



Dimensions				
No	mm	Tolerance	In	Tolerance
A	≥26.00		≥1.024	
B	23.05	+ 0.05 / - 0.05	.907	+ .002 / - .002
C	≥16.00		≥.630	
D	≥13.50		≥.531	
E	≥9.00		≥.354	
F	4.50	+ 0.10 / - 0.10	.177	+ .004 / - .004
G	30°		30°	
H	M24x1-6H			
I	24.25	+ 0.05 / - 0.05	.955	+ .002 / - .002
J	24.60	+ 0.10 / - 0.10	.969	+ .004 / - .004
K	15.40	+ 0.80 / - 0.80	.606	+ .031 / - .031
L	12.95	+ 0.10 / - 0.10	.510	+ .004 / - .004
M	M24x1-6g			

Color Code

Dome: Green	Ring: White	Basket: Dark Gray
-------------	-------------	-------------------

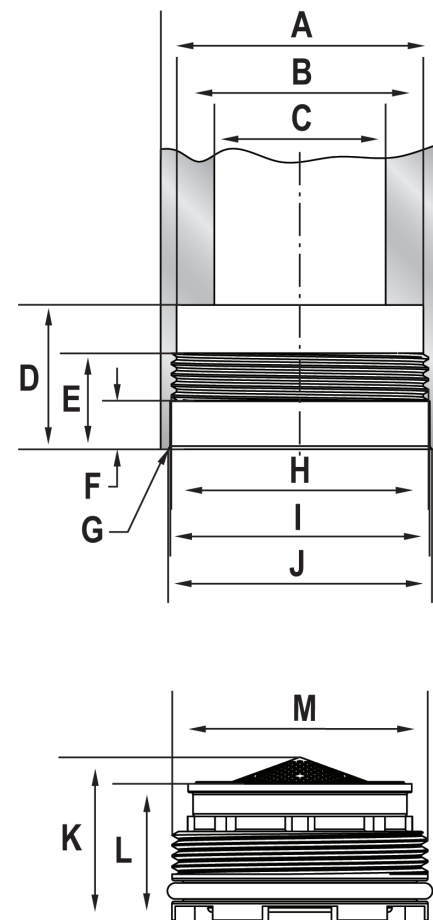

Technical Data

Material:

Body Acetal
O-ring Silicone

Working temperature: 150°F
Working pressure: 125 psi