

# Multi-Channel Indoor-Outdoor Thermohygrometer with Cable Free™ Sensor & ExactSet™ Clock

*MODEL: RMR-136HG*

## INTRODUCTION

Thank you for purchasing the RMR-136HG Multi-Channel Indoor-Outdoor Thermohygrometer with Cable Free™ sensor, model THGR268, and ExactSet™ calendar clock.

This basic configuration consists of the main unit that is the temperature and calendar clock station, and the thermohygrometer sensor remote unit. The main unit can support up to 3 remote sensors. Additional remote sensors are available.

The main unit has a large easy-read LCD screen that displays the indoor temperature, clock with calendar, and temperature and humidity data transmitted by the remote sensor to the main unit. The RMR-136HG also records the maximum and minimum indoor temperatures, and the maximum and minimum temperatures/humidity data transmitted from the remote sensor.

The clock is a radio-controlled ExactSet™ clock and includes a calendar. The clock automatically synchronizes time and date with radio signals received from the US Atomic Clock, one of the world's most accurate timepieces. Other clock/calendar features include three-language choice for day-of-the-week display, a four-step crescendo alarm and easy-change display modes. (To learn more about the US Atomic Clock visit the US Department of Commerce's National Institute of Standards and Technology website at: [www.nist.gov](http://www.nist.gov).)

## MAIN UNIT FEATURES

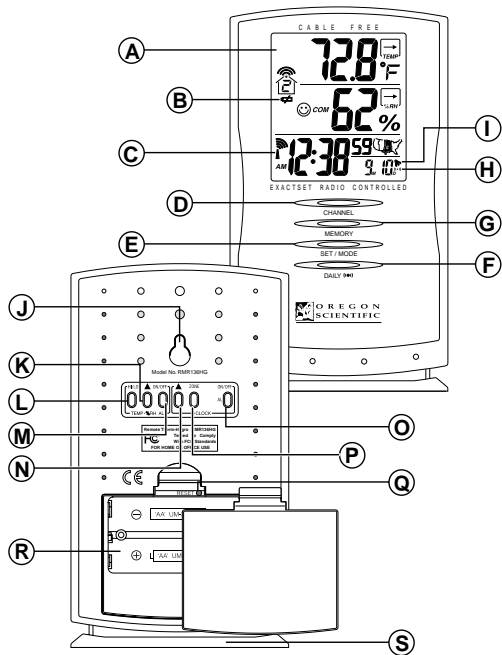

**A. THREE-LINE LCD DISPLAY**

Easy-read LCD display of remote sensor and indoor temperature-humidity data and calendar clock functions

**B. [  ] BATTERY-LOW ICON**

Indicates that the remote sensor or main unit battery power is low and that batteries need replacement

**C. [  ] US ATOMIC CLOCK SIGNAL RECEPTION ICON**

Graphically displays the radio signal reception strength

**D. [CHANNEL] BUTTON**

Sequences through and displays indoor and remote sensor channel data

**E. [SET/MODE] BUTTON**

Switches between display modes and saves user-selected settings

**F. [DAILY ((.)) ] BUTTON**

Sets the time for the alarm

**G. [MEMORY] BUTTON**

- Displays the maximum or minimum temperature and humidity readings
- Clears the stored maximum and minimum temperature and humidity data from remote sensor and the main unit

**H. [((•)) ] ALARM ICON**

Indicates that the alarm time is displayed

**I. [  ] ALARM-ON ICON**

Is displayed when the alarm is activate

**J. WALL-MOUNT RECESS**

For mounting the unit on a wall

**TEMPERATURE & RELATIVE HUMIDITY ALARM :****K. [ ▲ ] BUTTON**

Sets the remote sensor alarm values of minimum and maximum temperatures and humidity range

**L. [HIGH/LOW] BUTTON**

- Displays the maximum and minimum temperatures and humidity remote sensor alarms

-Saves alarm settings

**M. [ALARM ON/OFF] BUTTON**

Activates or disables the remote sensor alarms

**CLOCK :****N. [ ▲ ] BUTTON**

Advances the value of a setting

**O. [ALARM ON/OFF] BUTTON**

Activates or disables the clock alarm

**P. [ ZONE ] BUTTON**

Selects the US time zone

**Q. [RESET] BUTTON**

Returns all settings to their original default values

**R. BATTERY COMPARTMENT**

Accommodates two AA (UM-3) size batteries (included)

**S. REMOVABLE TABLE STAND**

For standing the main unit on a flat surface

## REMOTE THERMOHYGROMETER SENSOR

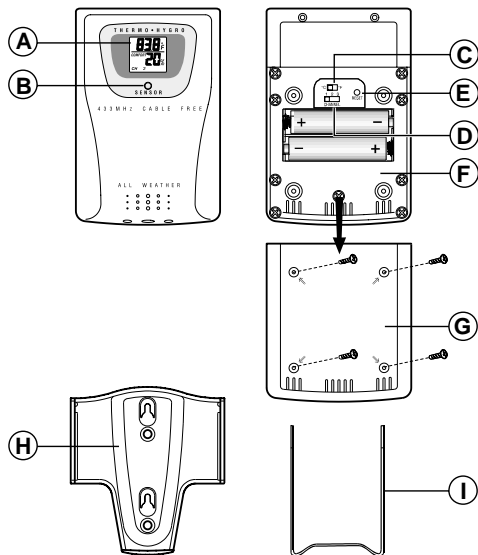

### A. TWO-LINE LCD

Displays the current temperature and humidity data measured by the remote sensor

### B. LED INDICATOR

Flashes when the remote sensor transmits a reading to the main unit

### C. °C/°F SLIDE SWITCH

Select between degrees displayed in either Centigrade (°C) or Fahrenheit (°F)

### D. CHANNEL SLIDE SWITCH

Assigns the channel number to the remote sensor

### E. RESET

Returns all settings to their original default values

### F. BATTERY COMPARTMENT

Accommodates two AA-size batteries (included)

### G. BATTERY DOOR

### H. WALL-MOUNT HOLDER

Supports the remote unit in wall-mounting

### I. REMOVABLE TABLE STAND

For standing the remote unit on a flat surface

## BEFORE YOU BEGIN

For best operation;

1. When using more than one remote sensor, assign a different channel to each of the remote sensors.

2. Insert batteries into the remote sensor **BEFORE** inserting batteries into the main unit.
3. Press **[RESET]** on the main unit after installing the batteries. Place the main unit close to the remote sensor as this will expedite initial signal synchronization between the main unit and the remote sensor.
4. Position the remote sensor within the effective transmission range of 21 - 32 yards (20 - 30 meters) from the main unit.

See “Wireless Transmission” for important information about wireless data transmission.

**Note:** Although the remote sensor has been designed for outdoor use, do not place the remote sensor in direct sunlight, rain or snow.

---

## REMOTE SENSOR BATTERY INSTALLATION & CHANNEL SELECTION.

---

To install / replace batteries:

1. Remove the screws on the battery compartment.
2. Using the **[CHANNEL]** slide switch, select the channel number of 1, 2 or 3 for that remote sensor.
3. The temperature can be displayed in either Celsius or Fahrenheit. Slide the **[°C/°F Slide Switch]** to either “C” or “F.”
4. Insert the batteries according to the polarities as shown.
5. Press **[RESET]**.
6. Replace the battery compartment door and secure its screws.

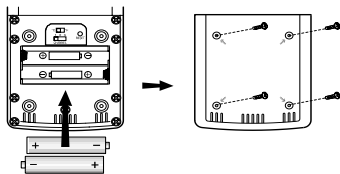

**NOTE:** Once a channel is assigned to a remote sensor, it can only be changed by removing and then reinserting the batteries or resetting the remote sensor.

---

## MAIN UNIT BATTERY INSTALLATION

---

To install / replace batteries:

1. Gently lift the tab on the battery compartment door and slide to remove door.
2. Install the batteries strictly according to the polarities shown.

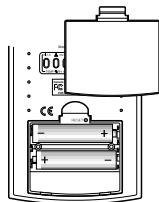

3. Press **[RESET]**.
4. Replace the battery compartment door.

---

## LOW BATTERY WARNING

---

The RMR-136HG features a low battery warning icon. This icon will appear on the second line of the LCD screen when the main unit batteries are low and need replacing. To determine low battery status of the remote sensor, press [**CHANNEL**] to sequence through the channels. When the remote sensor assigned to that channel number has low batteries, the low battery warning icon will be displayed.

---

## HOW TO USE THE TABLE STAND OR WALL MOUNTING

---

The main unit has a removable table stand, which when connected, can support the unit on a flat surface. Or the stand can be removed and unit can be wall mounted using the recessed hanging hole.

The remote unit also comes with a wall-mount holder and a removable stand.

### Main unit

Wall-mount

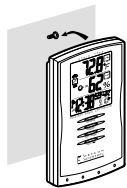
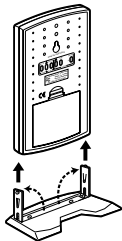

Table Stand



### Remote unit

Wall-mount

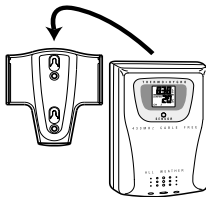
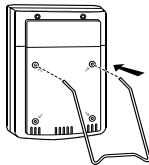

Table Stand



---

## THE RESET BUTTON

---

Pressing [**RESET**] will clear all settings and cause them to return to their original default values. Use a blunt stylus to hold down the button.

---

## GETTING STARTED

---

Once batteries are installed in the remote sensor unit, the sensor will start transmitting data to the main unit in 40-second intervals.

The main unit will start to search for remote sensor signals approximately 3 minutes after batteries are installed. Upon successful reception, the remote sensor temperature data will be displayed on the top line of the LCD screen and the respective humidity reading on the third line. The main unit will automatically update its readings every 40-second. The indoor temperature is displayed on the second line of the LCD screen.

If remote sensor signals are not received by the main unit, blanks “ --- ” will be displayed on the LCD screen and the kinetic wave icon will not be displayed for that remote sensor.

To trigger a remote sensor signal search:





- On the main unit, press and hold [CHANNEL] and [MEMORY] at the same time for 2-seconds. The signal search will take approximately 3-minutes.

The signal search will synchronize the signal transmission and reception between the remote sensor and main unit.

Should there be discrepancies between the reading shown on the main unit and that on the remote sensor repeat this step.

## CHECKING THE REMOTE AND INDOOR TEMPERATURE & HUMIDITY

The display of readings from a remote sensor or the main unit is a one-step procedure. The remote sensor channel or the main unit display is indicated in a box under the kinetic-wave icon.

<b>Kinetic-wave Icon</b>				
<b>Designated Display</b>	Indoor Display	Remote Display Channel One	Remote Display Channel Two	Remote Display Channel Three



To display temperature / humidity readings:

- Press [CHANNEL] to sequence through the choices of Indoor or remote sensor channel 1, 2 or 3.

If readings are not received from a remote sensor after 15 minutes, blanks “ --- ” will be displayed on the main unit LCD screen until readings are successfully received. Should this occur, check the remote sensor to verify that it is still in position and that the correct channel number has been selected. On the main unit then press and hold [CHANNEL] and [MEMORY] at the same time for 2-seconds to trigger a remote sensor signal search.



## HOW TO READ THE KINETIC WAVE DISPLAY

The kinetic wave display shows the signal receiving status of the main unit. There are three possible forms:

Searching for signal	
Signal search successful	
No signal received	



## THE COMFORT-LEVEL ICONS

The comfort level is based on the recorded relative humidity. An indicator will be displayed or show if the humidity level is comfortable, wet or dry.

Humidity Comfort-Level	 COMFORT	 DRY	 WET
	Comfortable	Dry	Wet

## TEMPERATURE AND HUMIDITY TREND INDICATOR ICONS

The temperature-trend and humidity-trend indicator arrow icons show the trends based on collected readings.

Arrow Indicator			
Temperature Trend	Rising	Steady	Falling

Arrow Indicator			
Humidity Trend	Rising	Steady	Falling

**NOTE:** If the temperature exceeds or fall below the temperature measuring range of the main unit or the remote sensor the main unit LCD screen display will show “*HHH*” or “*LLL*”. See “Specifications” for the temperature measuring ranges.

## REMOTE SENSOR SCANNING

The main unit can be set to automatically scan and display data readings from the remote sensor as well as indoor readings. When the remote-sensor mode is active, the main unit LCD screen will display the readings from one channel for approximately 4-seconds and then proceed to display the next channel data.

**To activate the remote-sensor scanning mode:**

- Press and hold [CHANNEL] for 2-seconds.

**To deactivate the remote-sensor scanning mode:**

- Press any button.

## MAXIMUM AND MINIMUM TEMPERATURE AND HUMIDITY

The maximum and minimum recorded temperature and humidity readings will automatically be stored in the memory.

**To display the maximum and minimum display memory:**

1. Press [CHANNEL] to select the channel to be checked.
2. Press [MEMORY] once to display the maximum (MAX) temperature and then again to display the minimum (MIN) temperature. The identifiers of “MAX” and “MIN” will be displayed as appropriate.

**To clear the memory:**

- Press and hold [MEMORY] for 2-seconds.

After clearing the memory, the maximum and minimum temperatures and humidity levels will be the same as current until new data readings are recorded.

## HOW TO USE CHANNEL-1 TEMPERATURE/HUMIDITY ALARM

Maximum and minimum temperature and humidity limits can be set for remote sensor channel-1 so that an alarm sounds when the user-selected limits are exceeded.

The maximum and minimum temperatures and humidity are sequentially displayed by pressing **[HIGH/LOW]**.

**The High-Low displays are as follows:**

Sequence	Respective Display
Press <b>[HI/LO]</b> X 1	Displays the HIGH temperature
Press <b>[HI/LO]</b> X 2	Displays the HIGH humidity
Press <b>[HI/LO]</b> X 3	Displays LOW temperature
Press <b>[HI/LO]</b> X 4	Displays LOW humidity

**To set the maximum or minimum temperatures or humidity level alarms:**

1. Press **[HI/LO]**. Remote sensor channel-1 will be displayed.
2. Press **[▲]** to set the temperature or humidity limits. Each press will increase the setting in increments of one (1) degree or humidity percentage. Press and hold **[▲]** for rapid-scrolling increments of five (5) degrees or humidity percentage.

3. Repeat steps 1 and 2 to set the maximum humidity setting and the minimum temperature and humidity settings.
4. When finished, press **[HI/LO]** to set another limit or wait 16-seconds and the unit will automatically return to the normal display mode. The appropriate HI, LO or both indicators will be displayed indicating the alarm status.

When the alarm activates the main unit LCD screen display will automatically switch to channel-1 if in another remote sensor channel mode and will flash. The alarm will sound for one minute unless disabled.

Press any key to momentarily stop the alarm. The alarm will automatically reactivate again if the limit continues to exceed the set limits.

### **NOTE: Temperature Range:**

The temperature range is from -58°F to 158°F (-50°C to 70°C). When setting the limits for the first time, the low/minimum limit will start at -58°F (-50°C) and the high/maximum limit at 158°F (+70°C). After the initial setting, the high/low limits will start from the temperatures as last selected.

### **NOTE: Humidity Range:**

The humidity range is from 2% to 98%. When setting the limits for the first time, the low/minimum limit will start at 2% and the high/maximum limit at 98%. After the initial setting, the limits will start from the humidity levels as last selected.

### **NOTE: Alarm Sounding:**

If a set limit is exceeded a second time while the alarm is sounding, the alarm will complete its first 1-minute cycle before sounding for another 1-minute cycle indicating that a limit has been surpassed a second time.



**To turn the alarm off:**

1. While the alarm is sounding, press **[HI/LO]**.
2. Then press **[ALARM ON/OFF]**.
3. The alarm has now been disabled and will not sound again until reactivated.

**To temporarily deactivate a sounding alarm:**

1. Press any button and the alarm will be temporarily deactivated. The alarm will sound again when a set limit is exceeded.

## INTERRUPTED SIGNALS

If the display for a particular remote sensor goes blank on the main unit LCD screen, press **[CHANNEL]** and **[MEMORY]** on the main unit at the same time for about 2-seconds to trigger a signal search between the main unit and the remote sensor.

**If the search does not reactive the signal reception, verify:**

1. The remote sensor is still in position.
2. The low battery warning icon is not displayed for the main unit or the remote sensor. Replace batteries as necessary.
3. The remote sensor is within the effective transmission range of 21 to 32 yards from the main unit, and that the transmission path is clear of obstacles and interference. Shorten the distance if necessary.

**NOTE:** When the temperature falls below freezing point, the batteries in the remote sensor will freeze lowering the voltage supply and the effective range.

## TRANSMISSION INTERFERENCE

Signals from household devices, such as door bells, home security systems and entry controls, may interfere with those of the RMR-136HG and result in temporarily reception failure. This is normal and will not affect the general performance of the product. The transmission and reception of temperature and humidity data readings will resume once the interference ends.

The success of wireless data transmission may vary and is directly related to where the remote sensor is placed and the environmental factors of that location. Should there be difficulty in data transmissions, verify:

1. The low battery warning icon is not displayed for either the main unit or the remote sensor. Replace batteries as necessary.
2. The remote sensor is within the effective transmission range of 21 - 32 yards from the main unit.
3. That there are no obstacle (like a transmission tower) or environmental reason (such as a steep hill) that is causing the interference or blockage between the main unit and the remote sensor.

If the difficulty continues, reposition the remote sensor to a different location and/or closer to the main unit.

## CALENDAR CLOCK DISPLAY MODES

The RMR136HG has two different time display modes:

**MODE 1: Local Time**

Hour, Minute, Second, Month, Day



**MODE 2: Local Time**

Hour, Minute, Day-of-the-Week, Month, Day



Press [SET/MODE] switch between the two time display modes.

**Note:** When [24 hr ▶ OFF / (⦿)] is pressed the bottom line of the main unit LCD screen will display the alarm time.

---

**EXACTSET™ CLOCK SIGNAL RECEPTION**

---

The split-second accuracy of the RMR-136HG is achieved through its internal antenna that responds to a special 60kHz frequency signal generated by the US Atomic Clock.

The RMR-136HG automatically activates its antenna upon battery insertion and within 3 - 7 minutes should receive the US Atomic Clock signal. Note that if the RMR-136HG is new allow up to 72 hours for the unit to receive the initializing signal. The strongest signal reception usually occurs between midnight and 4:00 AM. However, if the RMR-136HG has not picked up a signal

after 48 hours, remove the batteries, allow the unit to clear and then reinsert the batteries. Once the RMR-136HG receives the initial signal, updates are accomplished with greater ease.

**IMPORTANT:** Do not adjust the time zone until AFTER the clock has picked up the signal.

**NOTE: SIGNAL STRENGTH**

The RMR-136HG, like other radio frequency equipment, is most effective when it is placed near a window. The RMR-136HG may need to be moved or repositioned to receive a stronger signal. For best reception, place the RMR-136HG away from metal objects and electrical appliances to minimize interference.

On the bottom line of the LCD screen immediately to the left of the time display, is an icon indicating the signal reception strength. Please note that while the RMR-136HG is receiving a signal from the US Atomic Clock, the “receiving” icon will flash; once the signal reception is complete, the icon will stop flashing.

**Signal Strength Icons:**

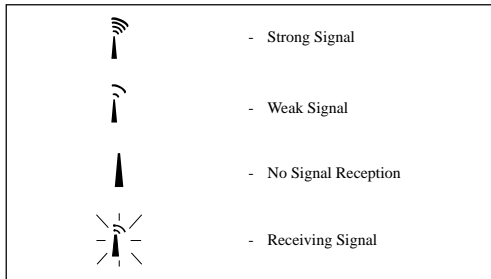

---

## SELECTING THE TIME ZONE

---

**CAUTION:** Do not press and hold [ZONE] for more than 3-seconds. Doing so will deactivate the automatic time signal reception capability. If the automatic signal reception is disabled, the signal strength icon will not be displayed. To reactivate the automatic signal reception, press [▲] for three seconds

On the bottom line of the LCD screen there is a map outlining the United States divided into the four US time zones.

1. Press and release [ZONE] to sequentially advance through the time zones from west to east.
2. The selected time zone will be darkened on the map.

To see the time in a different time zone:

1. Press and release [ZONE] until the desired time zone is darkened on the map icon. The time will automatically adjust to that time zone.

---

## SETTING THE CLOCK ALARM

---

1. Press [((.))]. The ((.)) symbol will appear on the bottom line of the LCD screen, lower right hand corner. The alarm time will also be displayed on the same line of the LCD screen.
2. Press and hold [((.))] until the hour digits of the alarm time begin to flash.
3. Press [▲] to advance the hour selection in increments of one hour, or press and hold for rapid advancement.

**NOTE:** When setting the hour, be aware of the AM/PM designations.

4. When the hour has been selected, press [((.))] again and the minutes digits of the alarm time will begin to flash.
5. Press [▲] to advance the minute selection in increments of one minute, or press and hold for rapid advancement.
6. When the alarm time is set, press [((.))]. The alarm will automatically activate itself. The active alarm status is indicated by the bell icon just above the ((.)) symbol.

---

## ACTIVATING/DISABLING THE CLOCK ALARM

---

To active the daily alarm, press [AL ON/OFF]. When the alarm is active, a bell icon will appear in the lower left corner of the LCD screen. If the alarm is not active, there will be no bell icon.

When the alarm sounds there are two ways to turn it off:

1. Press [((.))]. The alarm will remain active but will not sound again for 24-hours.
2. Press [AL ON/OFF]. The alarm function is disabled and will not sound again until reactivated.

**IMPORTANT:** The RMR-136HG has an automatic snooze feature. If the alarm is not disabled by either option 1 or 2 above, the alarm will automatically go into “snooze” once, sound again in 8 minutes and then temporarily turn itself off for 24-hours.

---

## SELECTING THE DAY-OF-THE-WEEK LANGUAGE DISPLAY

---

The RMR-136HG has three language choices for the day-of-the-week display: English (E), Spanish (S) and French (F). To select the display language:

1. Press **[MODE]** until the hour display begins to flash.
2. Press **[MODE]** five (5) more times and a single letter (E, S, or F) will be displayed on the LCD screen next to the time display.
3. Press **[▲]** to advance and sequence through the language choices.
4. When the language is selected, press **[MODE]** one time to exit the language setting mode and to return to normal time display mode.

---

## MANUALLY SETTING THE CLOCK

---

The RMR-136HG is an ExactSet™ clock and does not need to be set manually. However, instructions to set the clock manually are included and follow:

1. Press and hold **[MODE]**. The hour digits of the time display will begin to flash.
2. While the hour digits are flashing, press **[▲]** until the desired hour is reached.

**NOTE:** When setting the hours, be aware of the AM/PM designations.

3. When the hour is set, press **[MODE]** again and the minutes segment of the time display will begin to flash. Repeat the above steps to set the minutes, year, month, date and day-of-the-week.

4. When the last setting has been made, press **[MODE]** to exit the setting mode and return to the normal time display mode.

**IMPORTANT:** As soon as any manual setting changes are made to the clock, the low signal strength icon will be displayed indicating that the clock is now running on manual settings instead of signals from the US Atomic Clock. In manual mode, it is very unlikely that the RMR-136HG will receive signals from the US Atomic Clock. To reactivate signal reception, press **[RESET]** or remove the batteries, allow the unit to clear all settings and then reinsert the batteries.

---

## CUSTOMER ASSISTANCE

---

Should you have questions or require additional information about this product, please contact our Customer Service Department at 800-853-8883 or via email at: [www.helpme@oscientific.com](mailto:www.helpme@oscientific.com)

Please also visit our website at: [www.oregonscientific.com](http://www.oregonscientific.com)

---

## WARRANTY

---

Oregon Scientific warrants this product to be free of manufacturing defects for 90 days from date of retail purchase. Defective products should be returned to the place of retail purchase.

This warranty does not cover product subjected to tampering, misuse, abuse or accidental damage.

---

## PRECAUTIONS

---

This product has been designed and manufactured to provide you with year of service if it is carefully handled. Please follow these few precautions:

1. Do not immerse the main unit or remote sensor in water.
2. Do not clean the product with abrasive or corrosive materials. They may scratch the plastic parts and corrode the electronic circuit.
3. Do not subject the product to excessive force, shock, dust, temperature or humidity which may result in malfunction, shorter electronic life span, damaged battery and distorted parts.
4. Do not tamper with the product's internal components. Doing so will invalidate the warranty on the unit and may cause unnecessary damage. This product contains no user-serviceable parts.
5. Only use fresh batteries as specified in the user's manual. Do not mix new and old batteries as the old ones may leak.
6. Always read the user's manual thoroughly before operating the unit

---

## SPECIFICATIONS

---

### Temperature Measurement

#### Main unit:

Proposed operating range:	23.0° F to 122.0° F (- 5.0° C to 50.0° C)
Temperature resolution:	0.2°F (0.1° C)
Temperature compensation:	14.0° F to 140.0° F (-10.0° C to 60.0° C)
Relative humidity operating range:	25% RH to 90% RH

### Remote thermohygrometer sensor:

Proposed operating range:	4.0° F to 140.0° F (-20.0° C to 60.0° C)
Temperature resolution:	0.2°F (0.1° C)
Temperature compensation:	14.0° F to 140.0° F (-10.0° C to 60.0° C)
Relative humidity operating range:	25% RH to 90% RH
RF transmission frequency:	433 MHz
Number of remote sensors:	Maximum of 3
RF transmission range:	Maximum 32.5 yards (30 meters)
Temperature sensing cycle:	approximately 40 seconds

### Radio Controlled Clock

Main time set and synchronized by Radio Signal WWVB for USA	
12-Hr display hh/mm/ss format	
Date format in Month/day	
Day-of-the-week language:	Choice of English, Spanish and French
Four time zone with date and day	
2-Minute crescendo alarm	

### Power

Main unit:	2 pcs "AA"(UM-3)1.5V alkaline battery (included)
------------	--

Remote sensor: 2 pcs “AA” (UM-3)  
1.5V alkaline battery  
(included)

**Weight**

Main unit: 5.77 oz (without batteries)  
165 g (without batteries)  
Remote sensing unit : 2.82 oz (without batteries)  
80.5 g (without batteries)

**Dimension**

Main unit: 5.68”(L) x 3.36”(W) x  
0.98”(T)  
(142(L) x 84(W) x  
24.5(T) mm)  
Remote sensing unit: 4.2”(L) x 2.8”(W) x  
0.84”(T)  
(105(L) x 70(W) x  
21(T) mm)

---

**NOTE ON COMPLIANCE**

---

This product complies to standards and specifications of BZT, FCC and article number 334 of PTT.

This device complies with Part 15 of the FCC Rules. Operation is subject to the following two conditions: (1) This device may not cause harmful interference, and (2) This device must accept any interference received, including interference that may cause undesired operation.

**WARNING:** Changes or modifications to this unit not expressly approved by the party responsible for compliance could void the user’s authority to operate the equipment.

**NOTE:** This equipment has been tested and found to comply with the limits for a Class B digital device, pursuant to Part 15 of the FCC Rules. These limits are designed to provide reasonable protection against harmful interference in a residential installation. This equipment generates, uses and can radiate radio frequency energy and, if not installed and used in accordance with the instructions, may cause harmful interference to radio communications.

However, there is no guarantee that interference will not occur in a particular installation. This equipment does cause harmful interference to radio or television reception, which can be determined by turning the equipment off and on, the user is encouraged to correct the interference by one or more of the following measures:

- Reorient or relocate the RMR-136HG.
- Increase the separation between the affected equipment and the RMR-136HG.
- Consult an experienced radio/television technician for assistance.

**Product Name : Remote Thermo-Hygro**

**Model Name : RMR136HG**

**Responsible Party : IDT (USA) Mr. David Childers 19861 SW  
95 th Place Tualatin, Oregon 97062, U.S.A.**

**Tel: 503-639-8883**

---

## CAUTION

---

- The contents of this manual is subject to change without notice.
- Due to printing limitations, the displays shown in this manual may differ from the actual product displays.
- The manufacturer and its suppliers hold no responsibility to you or any other claim arising by using this product.
- The contents of this manual may not be reproduced without permission of the manufacturer.

