

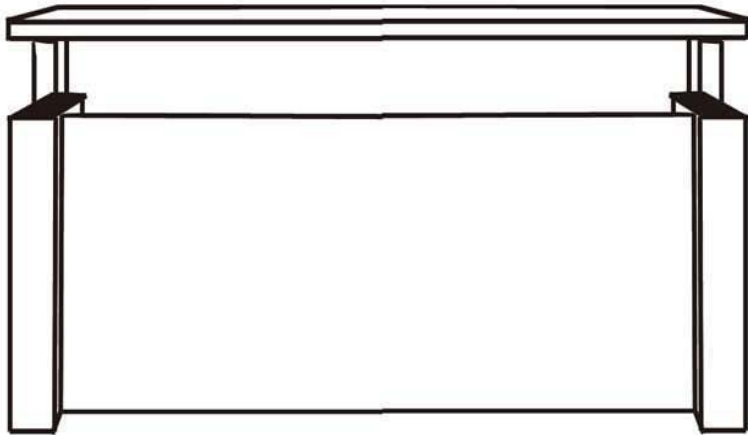









Assembly Instructions for Adjustable Height Executive Desks Y11741-Y11752

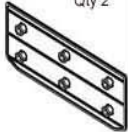

List of Hardware:

A	B	C	D Qty 19	E Qty 4
				
4MM Allen Wrench	5MM Allen Wrench	Wrench	M8x20 Machine Screw	M6x8 Machine Screw
F Qty 10	G Qty 4	H Qty 4	I Qty 2	J Qty 6
				
ST4.8x20 Wood Screw	Large Washer	Small Washer	End Cap	Cam Lock/Pin Set

List of Parts:

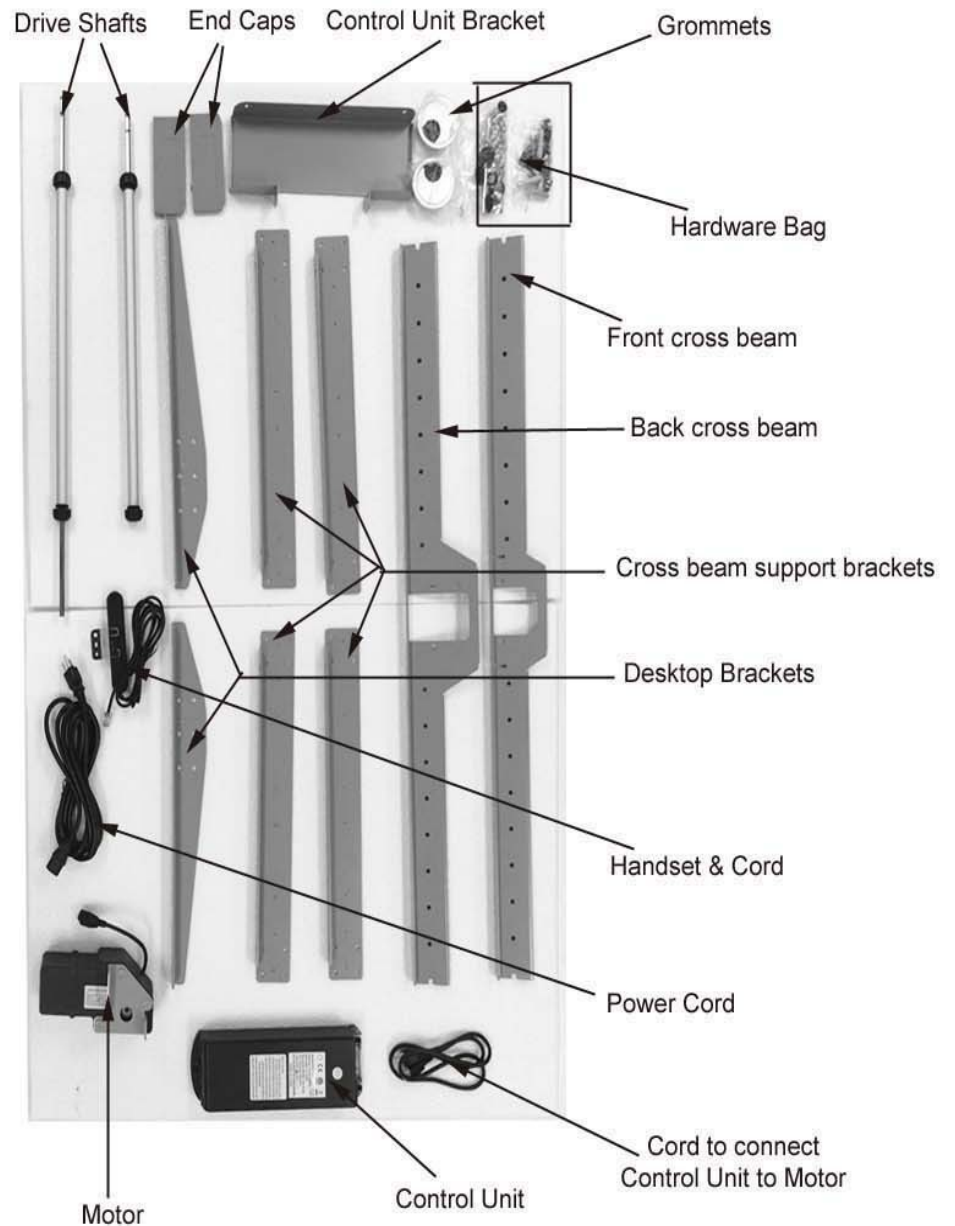

1.) Identify Left and Right Side Panels with assembled legs. Side Panels will be marked with L and R. Screw in Leveling Glides.

2.) Next, attach 3 cam pins to each left and right side panel. Stand up leg panels in position and attach front desk panel with (J) cam locks.

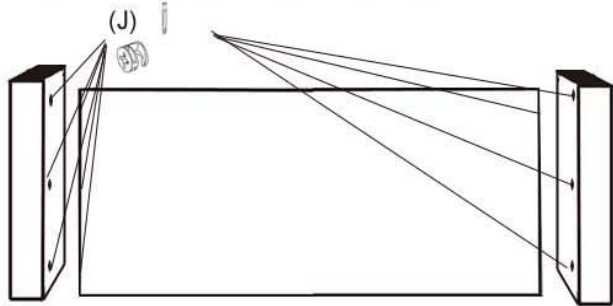

3.) Now, assemble the Back Cross Beam with two Cross Beam Supports, using the (D) M8x20 Machine Screws. Use two D screws to attach each Cross Beam support. Make sure length of entire cross beam matches the width of the desk.

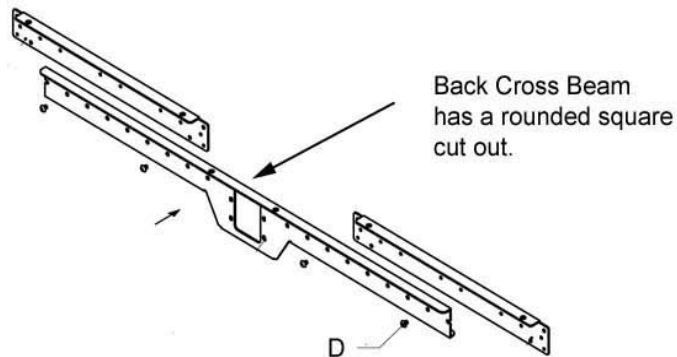

4.) Attach the back cross beam to the adjustable leg frame using two (D) screws per side.

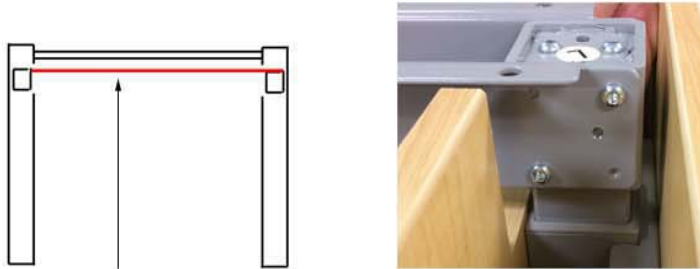

Attach Back Cross Beam to the side closest to the modesty panel

5.) Place the Motor inside the cutout. Use one (D) screw to attach bracket.

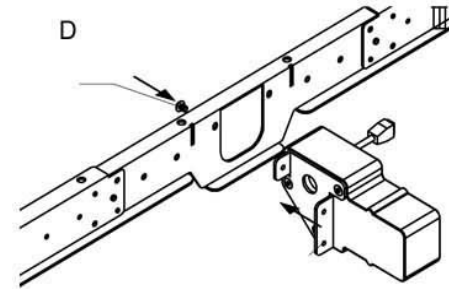

6.) The next step is to attach the Drive Shafts to the Motor.

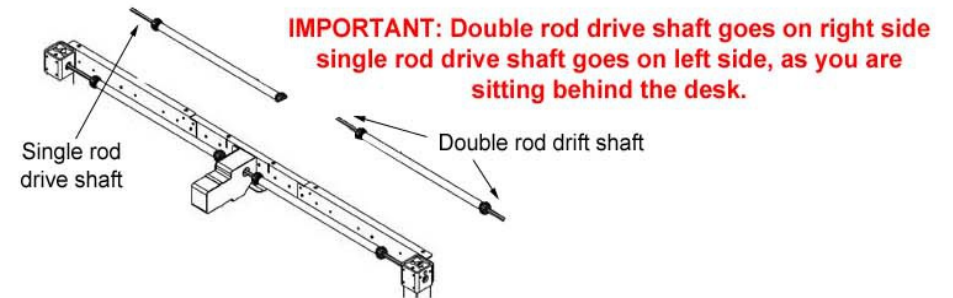

The Drive Shafts twist open and closed. Twist both open to allow you to slide the metal rod in and out of the shaft. Twist both shafts open and insert into motor and adjustable leg frames.

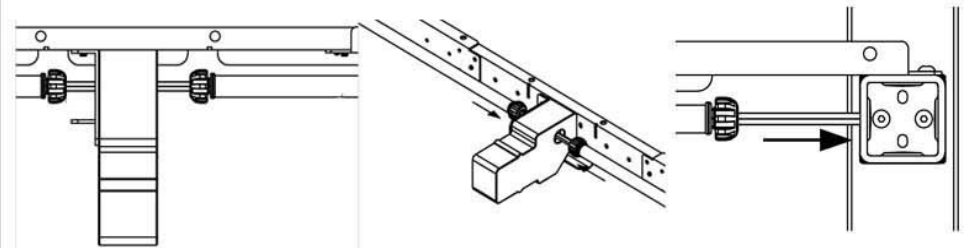
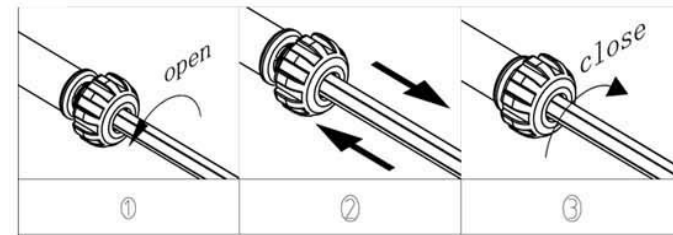

7.) Use (C) Wrench to tighten Drive Shafts.

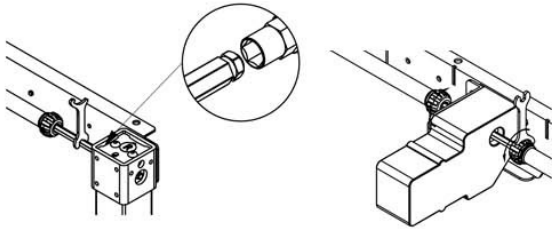

8.) Next, assemble Front Cross beam following same instructions as indicated in Step 3.

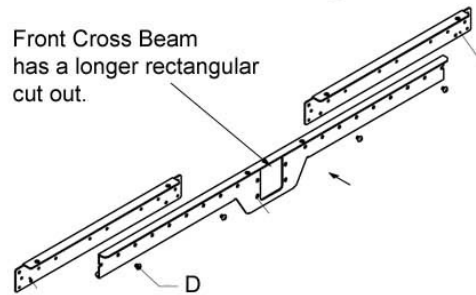

9.) Place Front Cross Beam so that the motor fits through the cutout. Attach motor with two (D) screws. Then, attach the front cross beam to the adjustable leg frame using two (D) screws per side, like shown in Step 4.

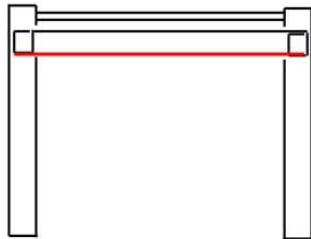

10.) Attach the Control Unit Bracket next. This fits into the slots on the Back Support Bracket. No screws needed to attach. Then, set control unit in bracket.

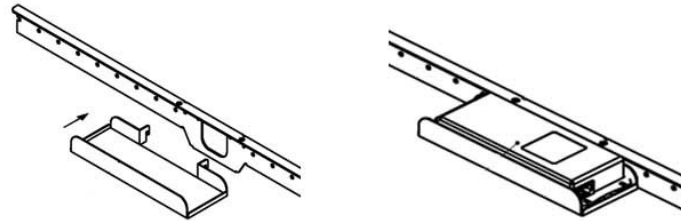

11.) Connect Control Unit to Motor as shown. Also connect power cord to motor and handset.

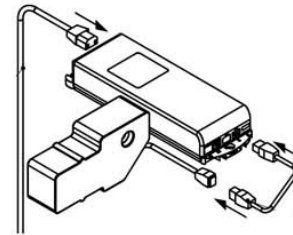

12.) Plug the power cord into a power outlet. Using the handset, raise the adjustable legs a few inches to make attaching the Desktop Brackets easier. Attach the Desktop Brackets with two (E) M6x8 Screws each.

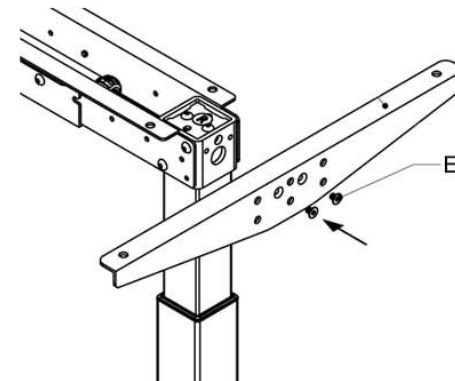

13.) Next, snap on the Desktop Bracket End Caps.

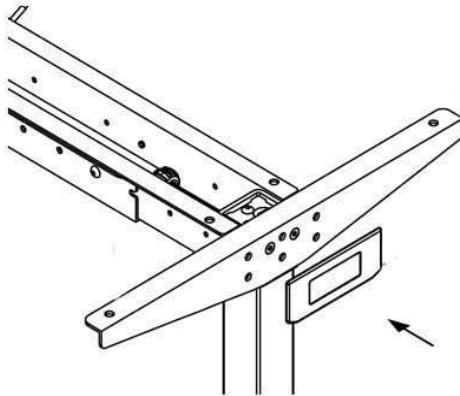

14.) Place (G) Washers on the Desktop Brackets as shown. Place (H) washers over Cross Beams as shown.

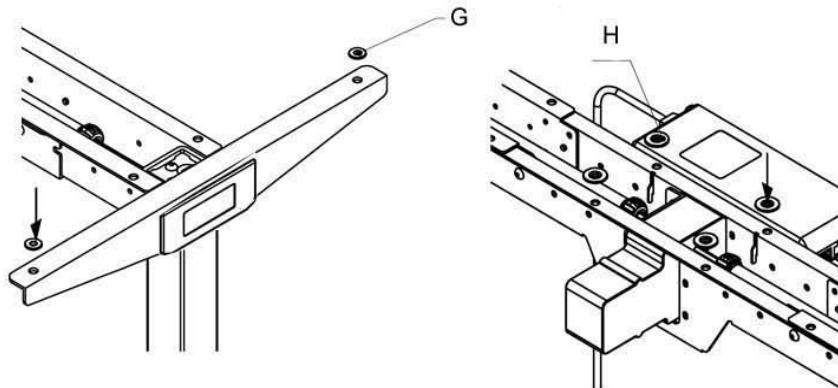

15.) It is time to mount the desktop. With a helper, lay the desktop on top of the assembled frame, making sure the front and back edges are flush with the leg panels and that there is 2" of desktop overhang on the sides of the leg panels. See picture on following page.

*****IMPORTANT***** It may be necessary to make use of the black washers included to level and adjust your desktop so that it is even with both side panels of the desk. After leveling, you will need to reinitialize the memory by pushing "M" and "Up" and then releasing. This will raise the desktop to the tallest height and then lower it to the desk height by stopping when it senses that is touching one of the side panels.



16.) Once the desktop placement is correct and the desk top is level, use a power screwdriver to drill the woodscrews into the desktop, through the frame to connect. Insert grommets once desktop is connected on all corners.

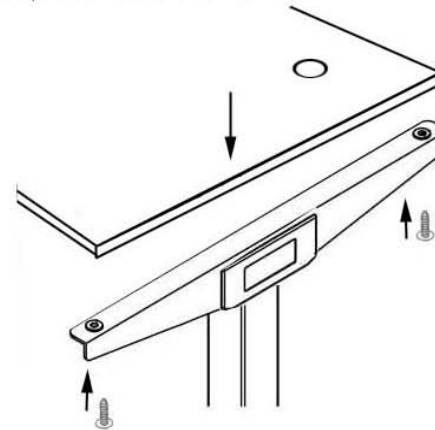

17.) Mount handset to underside of desktop with screws provided.

18.) Make sure all cords are connected to motor and plug your desk into a power outlet. Then see Initialization process on the follow page. **IMPORTANT: THE INITIALIZATION MUST BE COMPLETED IN ORDER TO ENSURE PROPER DESK FUNCTION.**



See next page

Questions? Please call 1-800-443-5117.
Customer Service available 8:30 - 5:00 Central Time, Monday - Friday



Initialization:

1. Press and hold the "M + Up" buttons. The controller will display (SET) and will start the initialization process. The desk will first go to the lowest position, then the highest position and finally stops in between. The initialization is completed is ready to use.
2. Initialization needs to be done every time when you are using different desktops.
3. Initialization will remember the highest and lowest position of the desk and you do not have to re-initialize if power goes out.
4. The lowest position of the system is (070) and this number will be shown on the controller when you press the down button and make it all the way down to the lowest position.

Operation:

1. Press Up button and the desk will stop when it reaches the highest position.
2. Press Down button and the desk will stop when it reaches the lowest position (070).

Memory feature:

1. Press and hold the S button and the controller will display (SET). Then, press one of the numbers and the system will remember this particular position.
2. Press one of the buttons that you have preset and the system will automatically adjust the desk to the height next time. If you want to stop, just press any button on the controller..

Overload protection:

1. When the weight on the desk is over 120Kg (265 lbs), the screen on the controller will appear (E01), which means the total weight on the desk is overloaded.

Anti-collision protection:

1. Press and hold "M + Down button + 3" for 3 seconds and the Anti-collision feature will be activated. The "point" on the screen will light up.
2. Press and hold "M + Down button + 3" for 3 seconds and the Anti-Collision feature will be deactivated. The "point" on the screen will be off. (The Anti-Collision feature is deactivated as a factory preset)
3. Anti-Collision preset code is (E16).
4. Grades of Anti-Collision: Grade 1 (Anti-Collision for light strength). Grade 2 (Anti-Collision for medium strength). Grade 3 (Anti-Collision for heavy strength). Press and hold "M + Up button + 1" for 3 seconds to setup these three grades, and the screen will show it as 1 , 2, 3.

Motor stalling protection:

1. When motor stalls the protection feature will be activated and (E02) will appear on the screen.

Customers can set the lowest position:

1. Press and hold "M + 1 + Down" button to go to factory setting for the lowest desk position, the Nixie light will glitter. Press Up button to increase and Down button to decrease. The range will be 10~150, press M to confirm the setting after it goes to the desired position.