

OWNERS MANUAL
For
Little Giant®
MODEL WRS-6 WASTEWATER
REMOVAL SYSTEM WITH 6-CIA PUMP**INSTALLATION**
OPERATION
REPAIR PARTS
SAFETY**BEFORE INSTALLATION:**

Little Giant Wastewater Kits are carefully packaged, inspected and tested to insure safe operation and delivery. When you receive your unit, examine it carefully to determine that there are no missing, broken or damaged parts that may have occurred during shipment. If damage has occurred, make notation and notify the firm you purchased the unit from. They will assist you in replacement or repair, if required. Read this manual carefully and also the enclosed pump manual.

This unit is designed to pump wastewater from laundry trays, washing machines, sinks or dehumidifiers. Unit is not designed to pump raw sewage, fluids other than water, or fluids with solids. Inlet screen will remove many solids over 1/8" diameter, but large amounts of solids can clog screen and result in pump failure. Maximum fluid temperature is 125°F. Unit is designed to fit under most sinks so in many cases it is not necessary to recess the unit into the floor.

ITEMS TO PURCHASE:

NOTE: Some state or local codes require all electrical and/or plumbing connections to be made by a licensed contractor. It is the customer's responsibility to determine codes involved and to comply with these codes. If user can install unit, items to purchase are:

1. Inlet piping, with trap and union (basin cover has 1 1/2" FNPT fitting).
2. Discharge piping, with swing check valve and union (basin cover has 1 1/2" FNPT fitting).
3. Vent piping (basin cover has 2" FNPT fitting).

SAFETY GUIDELINES

1. **CAUTION:** To reduce the risk of electric shock, pull plug before servicing this pump.
2. Read all instructions and safety guidelines thoroughly. Failure to follow the guidelines and the instructions could result in serious bodily injury and/or property damage.
3. Check local electrical and building codes before installation. The installation must be in accordance with their regulations.
4. During normal operation the pump is immersed in water. Caution must be used to prevent bodily injury when working near the pump:
 - a. The plug must be removed from the receptacle prior to touching, servicing or repairing the pump.
 - b. To minimize possible fatal electrical shock hazard, extreme care should be used when changing fuses. Do not stand in water while changing fuses or insert your finger into fuse socket.

ELECTRICAL CONNECTIONS

All wiring must meet local codes, and a licensed electrical contractor is recommended. The pump is supplied with a 3-prong vented plug. Plugs must be plugged into a grounded receptacle and vent tube must remain unobstructed for proper pump operation. Pump should be on a separate circuit with fuse or circuit breaker and GFCI (ground fault circuit interrupter). Be sure electrical supply matches pump nameplate data. Do not use extension cord. If installed in basement, plug connection should be 4 feet or more above floor, especially if basement floods. Be sure electrical connections cannot be reached by rising water. Under no circumstances should outlet box or receptacle be located where it may become flooded or submerged by water.

INSTALLATION

All plumbing must meet local codes. A licensed plumbing contractor is recommended. All fixtures connected to the WRS-6 Basin Kit must be vented according to state and local codes.

STEP 1: Determine proper location for unit. Unit should be located so that inlet is gravity-fed. Unit will not draw water up from a lower level. Position and level basin. Keep basin away from any item that could puncture basin. Position selected should be convenient to inlet, discharge and vent piping and electrical supply.

STEP 2: Plumb inlet. Using 1-1/2" threaded pipe, plumb inlet to basin cover fitting. Use a P-trap and a union next to the basin. Use pipe joint compound and hand tighten only on plastic fittings. Do not reduce below 1-1/2" piping.

STEP 3: Plumb discharge. Using 1-1/2" threaded pipe, plumb discharge to basin cover fitting. Use a swing check valve no more than 3" from top of basin cover and a union. Be sure check valve is installed in proper flow direction.

If check valve is installed backwards, no water will flow out of unit. Be sure discharge piping is sealed with pipe joint compound and that lift height of pump is not exceeded. Hand tighten only on plastic fittings.

STEP 4: Plumb vent. Plumb vent using 2" threaded pipe to fitting in basin cover. Use pipe joint compound on threads and hand tighten only on plastic fittings. The basin must be vented in accordance with state and local codes. The vent is essential for proper switch operation and must not be omitted or restricted.

CAUTION: Do not use a mechanical vent with this product. A mechanical vent will cause improper operation of the automatic switch.

STEP 5: Test Unit. Connect power cord to electrical supply as stated under "Electrical Connections." Secure power cord to piping with ties or tape. Fill unit with water through inlet. Pump should turn on with 7"-10" of water in tank, and turn off when 1"-3" of water is left in tank.

MAINTENANCE

Maintenance operations consist of cleaning basin inlet screen in cover, cleaning basin and limited pump maintenance. **WARNING:** Before any maintenance is performed, shut off water inlet and disconnect power cord from supply outlet. Pump may become hot in operation. Allow pump to cool before servicing.

Basin Screen – Remove (4) 1/4-20 screen cover plate screws, plastic cover plate, o-ring and screen. Clean inlet screen using a mild detergent and water. Examine o-ring and if deformed, replace with new o-ring. See replacement parts list.

Basin – Sediment may build up in basin causing pump to operate improperly. Remove (10) 1/4-20 screws from cover. Remove cord grommet and loosen cords to allow slack and then remove cover.

Remove pump and clean basin using a mild detergent and water. Reassemble in reverse order.

Torque screws 18-20 in.-lbs.

If pump alignment plate is removed, it must be reinstalled per pump alignment diagram.

Pump – Sediment or lint can clog pump and cause improper operation. If necessary, remove pump and pull off the pressed-in screen. Clean using a mild detergent and water and reinstall. Plastic pump base may also be removed to clean around impeller and inside base. Remove the 6 base screws and clean base using a mild detergent and water. Do not remove impeller. When reinstalling base, be sure seal ring is seated properly in groove and torque screws to 10-15 in.-lbs. See pump manual for other information. For any other pump repair, return the pump to a Little Giant authorized service center.

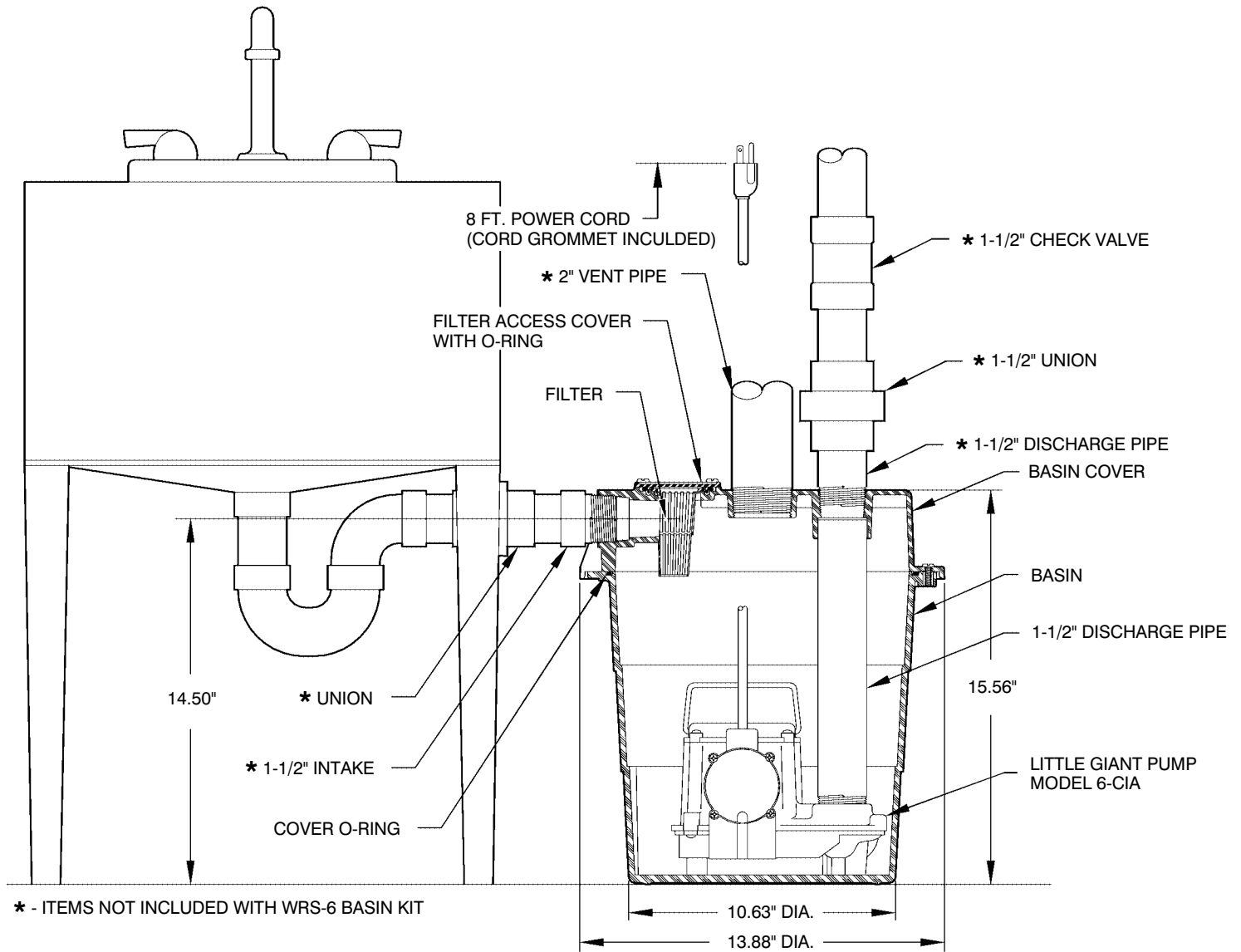

TYPICAL INSTALLATION

SPECIFICATIONS

MODEL NUMBER	VOLTS	HERTZ	AMPS	WATTS	GALLONS PER HOUR (GPH) AT HT.			SHUTOFF (FT.)	MAX. PSI
					5'	10'	15'		
WRS-6	115	60	9	720	2750	1750	750	18	7.8

**FOR TROUBLE-SHOOTING INFORMATION
SEE PUMP OWNERS MANUAL INCLUDED WITH
WRS-6 BASIN KIT.**

REPLACEMENT PARTS LIST			
ITEM	PART #	DESCRIPTION	QTY.
1	113130	BASIN COVER	1
2	901709	SCREW, 1/4"-20 X 1/2"	14
3	924125	O-RING, 11.975 I.D.	1
4	113129	BASIN	1
5	113140	DISCHARGE PIPE	1
6	506158	PUMP, 6-CIA, 115V	1
7	925016	CORD GROMMET	1
8	113131	INTAKE SCREEN	1
9	924126	O-RING, 3.225 I.D.	1
10	113132	COVER PLATE, SCREEN	1
11	113135	ALIGNMENT PLATE	1

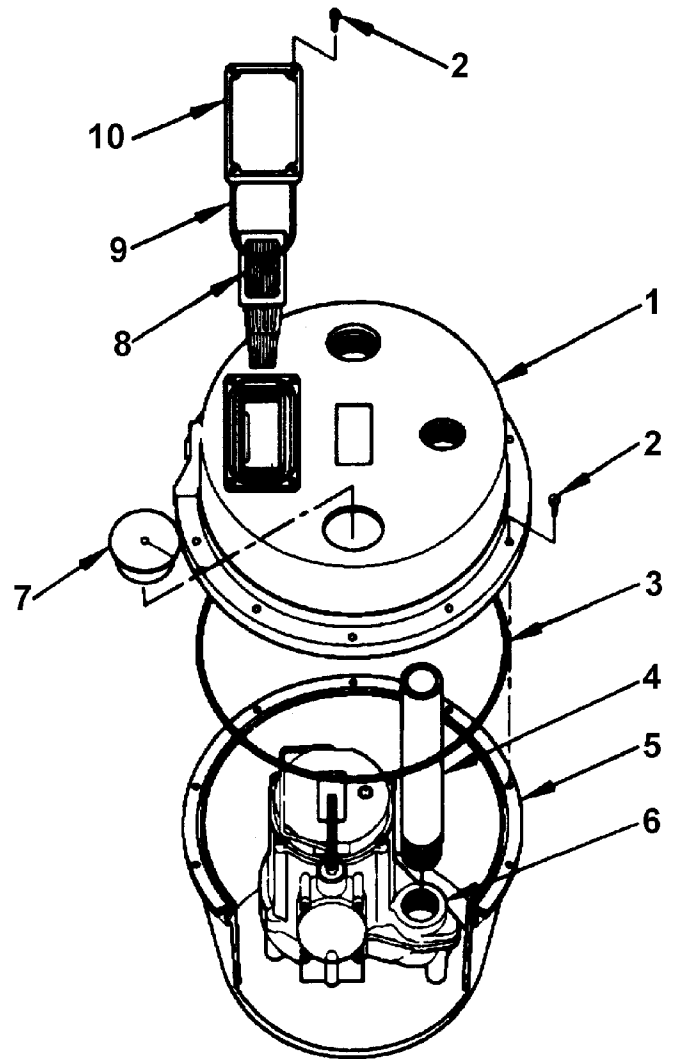
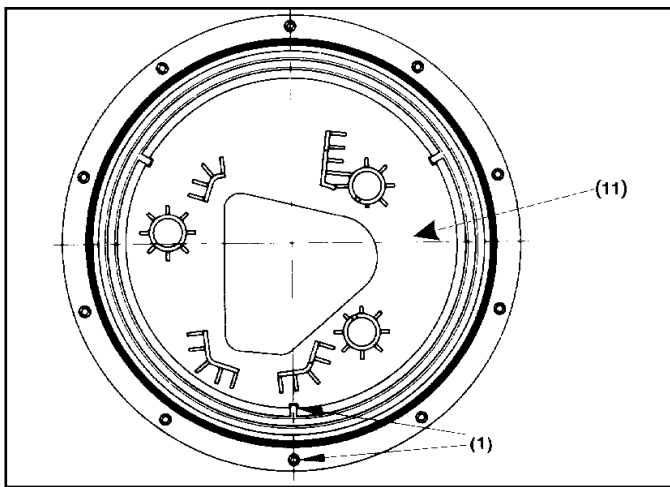

ONE YEAR LIMITED WARRANTY

For one year from date of purchase, Little Giant Pump Company will repair this unit if defective in material or workmanship. Warranty service is available by returning the unit prepaid to the factory. For further details, please consult the warranty statement on carton. This warranty gives you specific legal rights and you may also have other rights which vary from state to state.

KEEP THIS FOLDER

File this for safekeeping. It may be valuable to your for service under the terms of the warranty.

Date of Purchase _____ Name of Dealer _____

Serial # _____ Product # _____ Model # _____