



3778 South Kalamath Street, Englewood, CO 80110

Phone (303) 762-7373

Fax (303) 484-4070

www.presomatic.com
office@presomatic.com

Installation Instructions for Deadbolt Models 8101 8101OP 8102LT



Congratulations on choosing the strongest combination lock in the world! Presomatic Keyless Locks is proud to be the first to design and develop a lock of this kind.

This lock is unique and has many features not normally found in standard style locks. For easy installation please take 5-10 minutes to read the instructions first.

Your combination is _____ and is not recorded at the factory. This number can be found on the combination slides if required.

We hope you enjoy the use of your lock and if you need any assistance, please call us.

Sincerely,

Presomatic Keyless Locks

- **Table of Contents**

2	Table of Contents
3	What's In the Box
4	Step 1: Measuring the Door
5	Step 2: Cutting Opening in the Door
6	Step 2: Cutting Opening in the Door Continued
7	Step 3: Installing Deadlatch
8	Step 3: Installing Deadlatch Continued
8	Step 4: Installing Lock Body In Door
9	Step 4: Installing Lock Body In Door Continued
9	Step 5: Testing Lock Operation
10	Step 6: Mounting the Interior Cover
11	Step 7: Installing the Strikeplate
12	Changing the Combination Slides
13	Installing Spacers for Hollow Core Doors
14	Care and Lubrication
14	Troubleshooting
15	In the Event of a Lockout Scenario
15	Lock Operation Instructions
16	Accessories
17	Specifications
18	Exploded Parts Diagram
19	Exploded Parts Continued

• What's In the Box

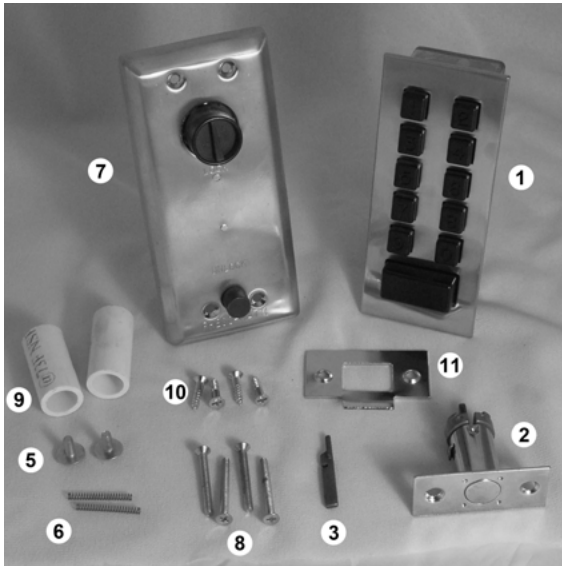

STANDARD CONTENTS:

1. Lock Assembly
2. Deadbolt Assembly
3. 1 Actuator*
4. 1 Brass Pin*
5. 2 Flathead Screws*
6. 2 Reset Button Springs*
7. Interior Cover
8. 4 (1-1/2") Interior Cover Screws
9. 2 Plastic Spacers for Hollow Doors
10. Strikeplate
11. 4 Wood Screws
12. Installation Templates

* These parts are already installed on the lock when it arrives from the factory.

TOOLS REQUIRED:

1. Flathead Screwdriver
2. Phillips Screwdriver
3. Tape Measure
4. Pencil or Scratch Awl
5. Chisel or Tin Snips (metal doors)
6. Hammer
7. Electric Drill
8. 1" Wood Drill Bit/Hole Saw
9. Jigsaw or Sawzall (metal doors)



Important! Verify that you received all components and have all tools necessary on hand before beginning. Contact us for replacement of any missing parts.

NOTE: References to the “outside” or “face” of the door in these instructions is the side you desire the keypad to be on.

● Step 1: Measuring the Door

Measuring the Door:

Fold the included Ruler Template along its indicated line, and place on the door (see photo on right). The door thickness should be 1-3/4” (45mm). If the door is significantly thinner or thicker, additional hardware may be required for installation.

Using the door ruler, mark the center of the outside edge of the door to use as a guide for drilling the hole for the bolt.

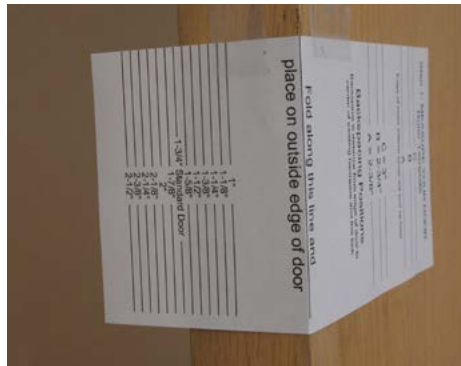

Doors with existing hardware:

Place the ruler on the door. Match exact center of existing hardware and determine the backspacing as well as ensure that the interior cover (as noted on the ruler) will not interfere with any door accents such as windows or trim.

Ensure that the backset of your existing hardware matches the backset of the lock ordered, if it does not your lock may not cover the hole left by the old hardware.

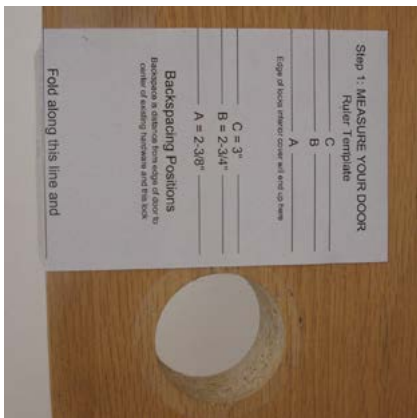

Doors without Existing Hardware:

Using the ruler, ensure that the lock’s interior cover will not intersect or interfere with any existing door hardware, raised panels, or windows.

Since this door is solid, the lock won’t interfere with any existing door features or hardware.

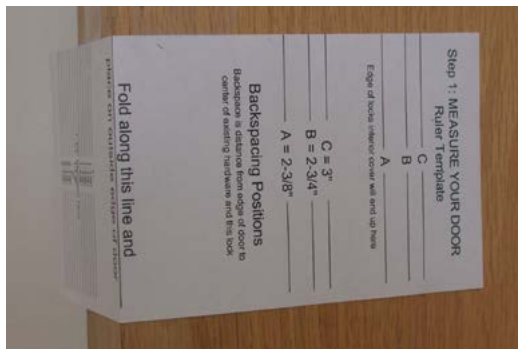

• Step 2: Cutting Opening in the Door

Place the folded template on the face of the door, as shown to the right.

Use tape to hold the template on the door, making sure to place tape in multiple spots as to avoid the template moving during installation.



We recommend installing the lock 4 ft (1.2 m) from the bottom of the door.

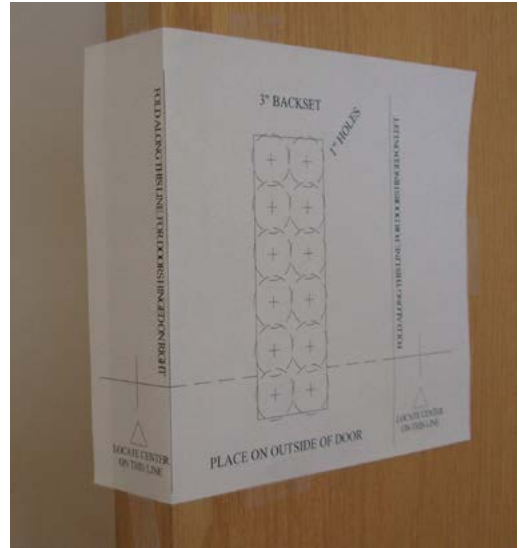

If your door does not have existing hardware, locate center of door edge on line shown on the left. Mark this spot for drilling the bolt hole **after cutting square opening for lock**.

If you are replacing an existing lockset, place the template so this line is centered over the existing bolt hole.

If your door is thicker than 1-3/4", you must locate the mark for 7/8" from front edge of door.

Drill a 1" hole on the mark straight through - parallel to the ground - to the rectangular opening.

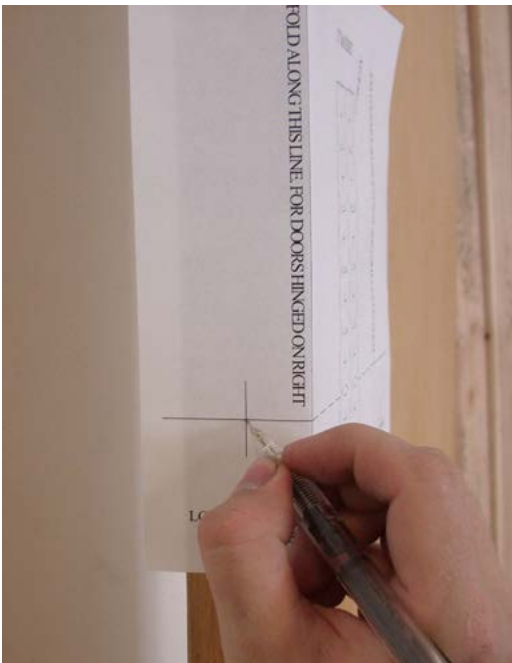

Any method will work for cutting the opening in the door. However, we recommend the hand/coping saw method for wood and fiberglass doors, and the jigsaw method for metal doors.

- **Step 2: Cutting Opening in the Door - Drill**

Place a mark on each of the circles contained in the template. Drill a small pilot hole into each of these marks. Make sure there is a mark on the edge of the door to indicate where the bolt hole is to be drilled (if you are not replacing existing hardware) and remove the template.

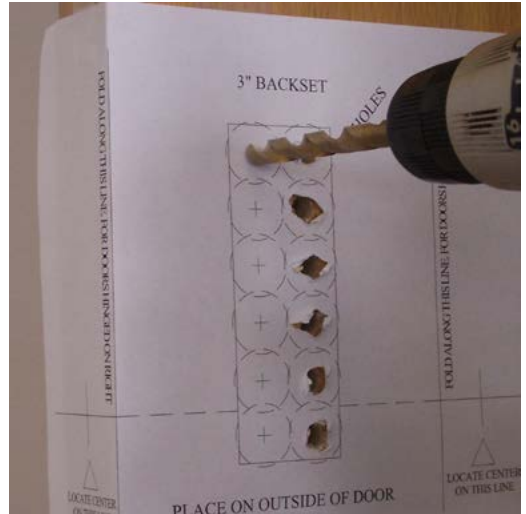

Using a 1 inch wood bit or hole saw, drill into each of the pilot holes.

Remove the remaining points left over from the hole saw drilling using a jigsaw, coping saw, sharp chisel, or wood rasp.

(It is not recommended to use chisels on anything but solid wood doors, as they can cause splintering.)



- **Step 2: Cutting Opening in the Door - Jigsaw**

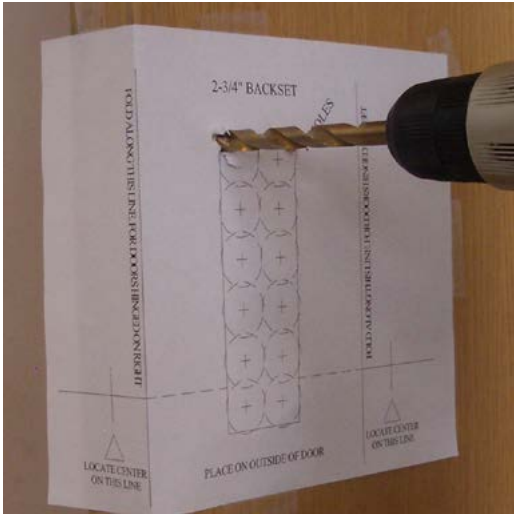

Using the template, drill out the four corners of the square hole using a 7/16" drill bit (or another size that will fit the blade of your jigsaw) ensuring that the bit does not go outside the marked lines of the template.

Make sure that the edge of the door is marked where the hole will be bored for the bolt, if you are not replacing existing hardware, and remove the template.

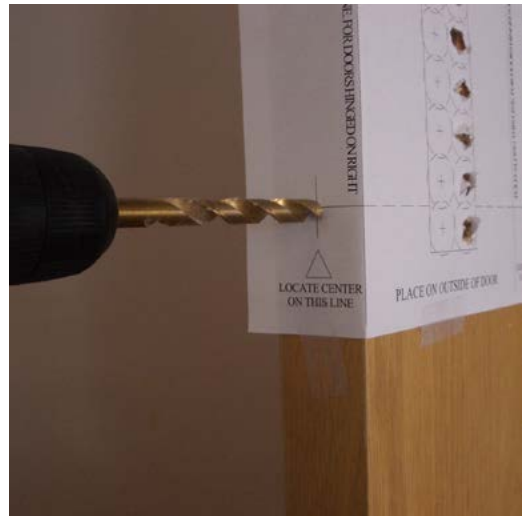

Using a ruler or straightedge, connect the four corners to act as a guide when the opening.

Use a slow cutting speed (a fast cutting speed can cause the blade to wander on the backside of the cut) and follow the lines carefully. Allow the speed of the blade to do the cutting, do not muscle or try and speed through the cut, as it will produce a rough cut and mishapen hole for the lock.

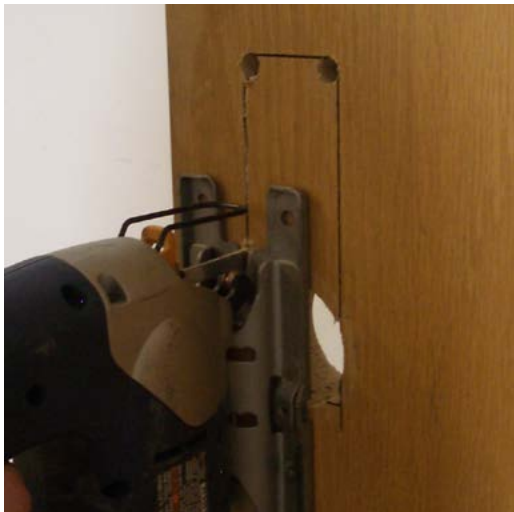

- **Step 2: Cutting Opening in the Door - Coping Saw**

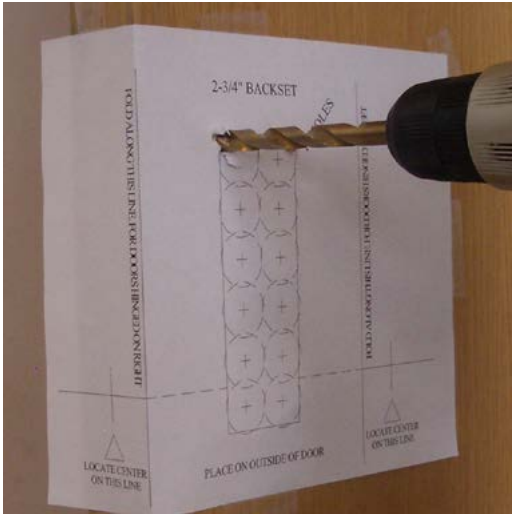

Using the template, drill out the four corners of the square hole using a 7/16" drill bit (or another size that will fit the blade of your jigsaw) ensuring that the bit does not go outside the marked lines of the template.

Make sure that the edge of the door is marked where the hole will be bored for the bolt, if you are not replacing existing hardware, and remove the template.

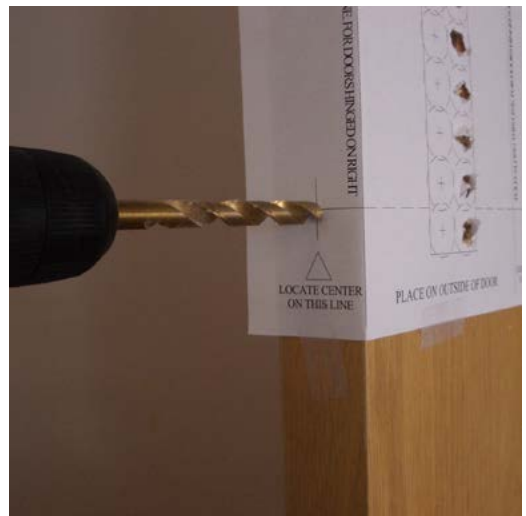

Using a ruler or straightedge, connect the four corners to act as a guide when the opening.

Insert the fine toothed blade of a coping saw into one of the holes and begin cutting, following the line and being careful to make the cut straight, so as not to cause the line to wander on the backside of the cut. Repeat until the rectangle is cut out.

● Step 3: Installing Deadbolt

Models 8101 and 8101OP:

Drill out channel inside deadbolt hole for lugs to travel on bolthousing with a 3/8" to 7/16" drill bit. Use the picture to the right as a reference.

You can check the clearance by holding the deadbolt in place, as if it were installed, and extending the deadbolt using the actuator.

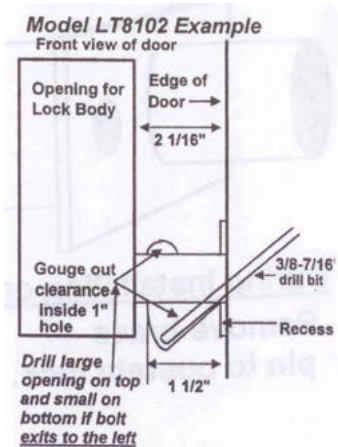
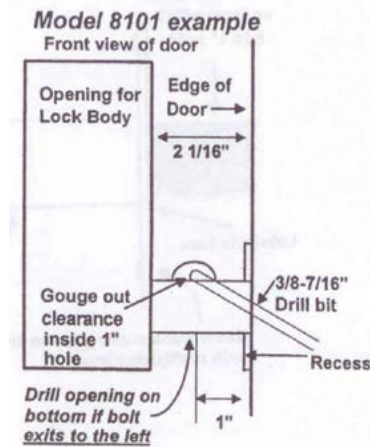

Model 8102LT:

Drill out channel inside deadbolt hole for lugs to travel on bolthousing with a 3/8" to 7/16" drill bit, using the picture at left as a reference.

You can check the clearance by holding the deadbolt in place, as if it were installed, and extending the deadbolt using the actuator.



IMPORTANT: The above photos represent installation from the front side of door, with bolts that exit the right side of door. If your door is installed to swing from the opposite direction, you must reverse the drilling of channels top to bottom.

• Step 3: Installing Deadbolt Continued

Insert deadbolt housing in opening with the tail towards backside of door. Mark bolt face plate on door edge and use a chisel to countersink the plate before attempting to put the lock in the door.

Lubricate the deadbolt only with a spray lubricant such as WD-40, silicone spray, etc. The bolt assembly was put together with a metal coating solution and must now be lubricated for smooth operation. **Do not** lubricate the lock itself (See step 8).

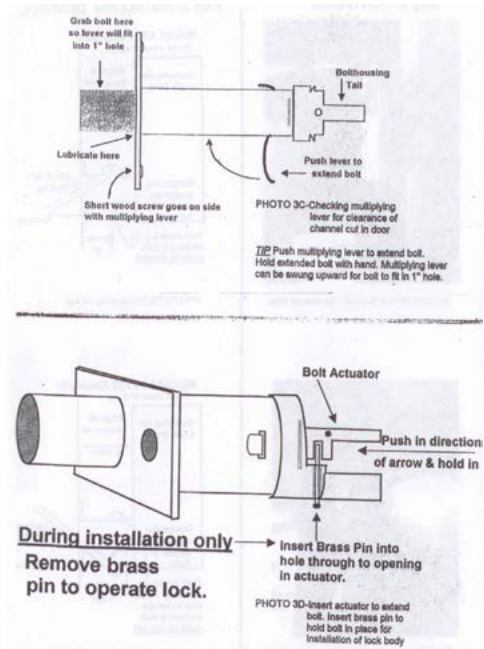

IMPORTANT: Do not secure the deadbolt with wood screws. This is completed in step 5 to ensure proper alignment for the operation of the lock.

• Actuator Orientation

When removing the deadbolt from the lock (as it was shipped from the factory) the deadbolt actuator may fall out. Please see the diagram at right for the correct orientation to reinstall the actuator with the deadbolt.

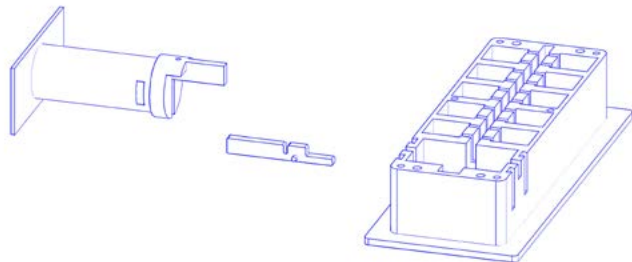

- **Step 4: Installing Lock Body In Door**

If door is hollow, see the step on installing hollow door spacers at the **Additional Steps** section.

Insert lock into opening with number buttons facing outside. Match up the bolt casting to the slot in bottom side of lock and **make sure dovetails in lock body mate with dovetails in bolt casting**. Push lock on as far as possible. It should be a snug fit and will be set in the final position with screw in the next step.

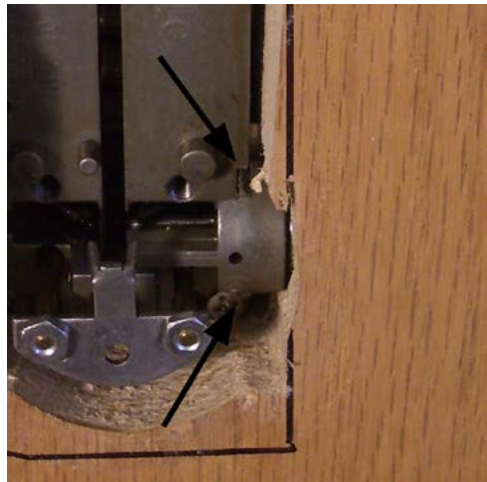

Insert reset button springs (1 on each side of lock) into threaded screw holes. (Shown left)

Next, insert the large flathead screws into the same holes. (Shown right) On bolt side, only tighten until bolthousing casting is tight against lock body. **Then back screw off 1/4 turn. Do NOT over tighten.** On other side tighten second screw until snug.



Once the deadbolt is installed, remove the brass pin retaining the actuator.

- **Step 6: Mounting the Interior Cover**

Using one hand, press and hold the reset button on the front of the lock, this moves the unlock plate away from the lock, giving easier access. Next, position the cover at approximately a 45 degree angle, and insert the unlock button through the hole in the center of the pull plate.



Next rotate the interior cover so the arm of the lever goes into the slot above the reset button pin. Insert the four screws into the holes on the corner of the interior cover, but do not tighten them yet.



Before tightening, align lock body until straight and latchbolt faceplate is flush and straight in counter-sunk hole. **GENTLY** tighten interior cover screws until snug (DO NOT over tighten) while checking for smooth operation of unlock button.

GENTLY secure latchbolt housing with wood screws until flush (DO NOT over tighten).

IMPORTANT: Excessive tightening of interior cover and latch bolt can cause binding and failure of internal parts.

RULE OF THUMB: Hand tighten interior cover screws till flush, then 1/4 turn.

Test unlock button 2 or 3 times with door ***in the open position*** by using the lock test method outlined in step 5.

- **Step 7: Testing Lock Operation**

Operation of the lock should be tested once it is fully assembled, but before closing the door, to ensure that the lock functions correctly and smoothly. To test the operation of the lock, simply press the reset button (large rectangular button on the face of the lock) with the door open. The bolt should extend from the lock. Process the combination and the door should unlock automatically.

Move to the interior of the door, and with it still open press the lock button (large button at the top of the interior cover) fully to extend the bolt. Press the unlock button to retract it.

If any operation does not succeed or is not smooth, do not close the door. Check for binding of the bolt and the lock itself. If no binding is found, contact us immediately.a

- **Step 8: Installing the Strikeplate**

Extend the bolt from the lock, as noted in the previous step. Close the door to line up the bolt with the jamb. If the lock is replacing existing hardware, you should be able to replace the existing strikeplate with the new one.

If this is a new installation, use a pencil to mark the top and bottom of the bolt on the jamb. Use these marks to drill a 1" hole into the jamb (3/4" deep for 8101 and 8101OP, 1-1/4" deep for 8102LT). Mark jamb and use a chisel to recess the strikeplate into the jamb. Install with provided wood screws.

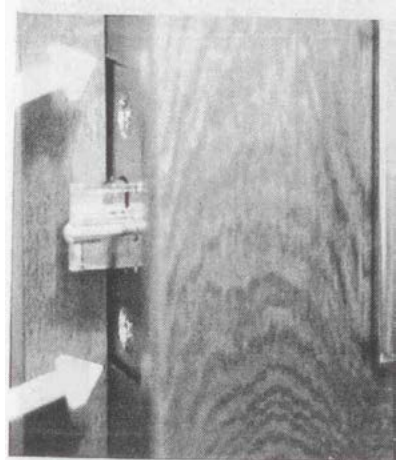

PHOTO 7A-Mark door jamb at edges of latchbolt face for alignment



IMPORTANT! Align strikeplate with bolt so that the bolt is loose in the strikeplate. If the bolt sits against the strikeplate it will cause binding, and the lock will only open if the combination is processed and the door is wiggled.

- **Changing the Combination Slides**

Using a Phillips head screw driver, remove the interior cover. With the interior cover removed, loosen and swing the two spring clips out of the way.



Remove the combination slide cover plate.

Remove the combination slides from the lock. Replace with the new combination slides in the same orientation.

With the combination slides replaced, reinstall the slide cover plate and spring clips. Test the new combination slide before reinstalling the interior cover.



More pictures and a video on this process can also be found on www.presomatic.com

- **Installing Spacers for Hollow Core Doors**

Spacers must be installed in any hollow core doors to prevent the door from crushing together.

Installations in hollow core doors without spacers will cause operating problems with the lock. If spacers are too long, you can sand, file, or trim the edges slightly.

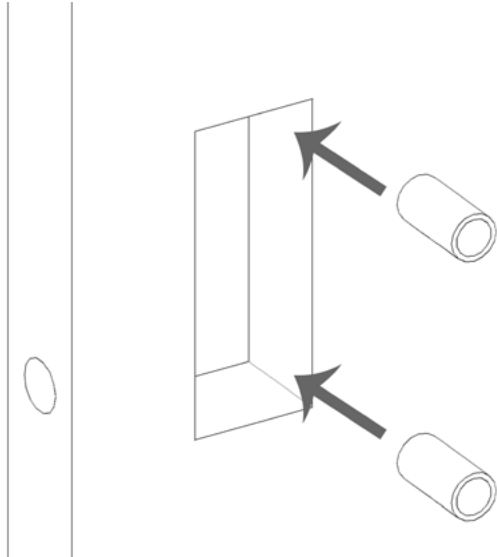

- **Lock Operation Instructions**

To operate the lock from outside: To **unlock** the door - press the combination numbers in correct sequence, making sure to depress buttons all the way. Latch will retract automatically. If the number is entered incorrectly, push the large **RESET** button to clear the combination. To **lock** the door, just close the door. It locks automatically!

To operate lock from inside: To **unlock** the door, press the unlock button. The latch will retract automatically. To **lock** the door, just close it. The latch will lock automatically.

To set the **NIGHTLATCH** feature (if equipped) so the lock cannot be opened from outside by use of the combination, push the nightlatch button (large button at the top of the interior cover) in all the way and turn to the right 1/6 of a turn. Button should remain depressed. To release, turn nightlatch button to up position. Button should return to the out position.

- **Care and Lubrication**

Clean the lock and exposed surfaces with a damp cloth or mild glass cleaner. Use of harsh solvents or abrasives will deteriorate the finish of your lock. Lubrication is only necessary on the latchbolt itself occasionally, or if the latch mechanism begins to stick.

***DO NOT* lubricate the lock - all parts are corrosion resistant and self lubricating. Lubrication of the lock itself can cause malfunctions and erratic behavior.**

- **Troubleshooting**

I want to test the lock before putting it in the door: The lock has been tested at the factory before being shipped. If you would like to bench test the lock follow the steps outlined in Step 5. Ensure the lock remains upright as if installed in the door.

The latchbolt is backwards when I install it in the door: The latchbolt will need to be reversed to fit the swing of your door. Follow the steps outlined in Step 3: Reversing the Latchbolt.

My lock does not always lock when the door is closed: Doors with closers or heavy weather stripping may prevent the latch from engaging the strikeplate correctly. If you can lock the door by pushing the door closed, adjust the strikeplate outward.

My lock works when bench testing, but will not unlock in the door: The latch is operated by spring pressure. Doors with heavy weather stripping or warping will cause the latch bolt to bind on the strike plate. To test for binding, close the door and process the combination holding the last number down with one hand and “wiggling” the door with the other. If the door unlocks, binding is occurring and the strike plate is most likely interfering with the latch operation. Adjust the strike plate to give it more room.

My door is not 1-3/4” thick on the white ruler template: If the door is thinner than 1-3/4”, you will need spacers or escutcheons to ensure the lock is correctly positioned in the door.

If the door is thicker than 1-3/4” you may require an adapter kit. Verify your door thickness with the white ruler template and contact your dealer or Presomatic directly for correct parts.

● Accessories

Part #	Name	Description	Cost
8105	Combination Slides	Random 4 number combination slides to change combination. Multiple sets available in different or alike combinations.	\$10.00
8105S	Custom Number Combination Slides	Custom made to order 4 digit number combination slides.	\$15.00
8105M	Master Combination Slides	Mastered combination slides for multiple installations. Two combinations are cut into each pair of slides, one 6 digit master and one 4 digit individual. For use in 4 digit lock models only.	\$15.00
7105	7 Digit Combination Slides	7 Digit combination slides to change combination in 7 number lock models only. Stock numbers only.	\$15.00
NL-10	Number Labels	Self adhesive clear mylar labels with bold white numbers 1-0. Labels are applied adjacent to number buttons on lock face.	\$2.00
K-BOX	Weldable Gate Box	Especially designed for gates - fits all 3" backset Presomatic models. Lock fits into box.	\$33.00
20	Door Thickness Adapter	For nonstandard doors 1-13/16" to 2-1/4" thick. Specify for deadbolt or deadlatch model.	\$10.00
110	1/4" Spacer	For doors 1-1/4" to 1-5/8" thick. Black only.	\$10.00
120	1/8" Spacer	For doors 1-5/8" thick. Black only.	\$15.00
46	Standard Strikeplate	Comes with models 8101 and 8102LT.	\$6.00
50	Doorstop Strikeplate	Comes with models 8200 and 8200A.	\$10.00
EWSP	Extra Wide Strikeplate	Hardened steel for use on extra wide door jambs.	\$9.00
LS	Lock Shield	Visual shield fits over lock.	\$29.00
8	Stay Open Lever	For use with 8200 and 8200A model locks. Keeps lock in the unlocked position to allow unrestricted access. Installs on interior plate.	\$10.00

• Specifications

PRESOMATIC locks can be installed in solid and hollow core doors made of wood, metal or fiberglass and are universal to fit both right and left hand doors.

ADJUSTABILITY Locks are preset at factory for 1-3/4" thick doors. All models are adjustable for 1-3/8" to 2-1/4" doors inclusive. Spacer plates, which fit under lock face flange, are required for doors 1-3/8" to 1-5/8" inclusive. These spacers do not alter the security of the locks. Adapter kits, which cahnge the length of the unlock and lock button (on applicable models) are required for doors 1-13/16" to 2-1/4" inclusive.

BOLT HOUSINGS A dovetail mounting system interlocks the bolt into the lock body itself and forms a solid one-piece construction for durability and security.

REQUIRED OPENINGS 1-7/8" wide by 5-3/8" high. Installation diagram below shows distance from door edge and height. Installation template provided gives exact positioning.

LATCH BORE Latch hole is 1". Some additional drilling is required for 8102LT deadbolt models.

BOLT DIMENSIONS Model 8101 deadbolt is .850 diameter with 5/8" throw. Model 8102LT deadbolt is .850" with 1" throw. Model 8200 and 8200A is .720" diameter with 9/16" throw.

LATCH FACES All models have a 2-1/2" by 1-1/8" latch face. Latch faces are made of chrome plated steel.

STRIKE PLATE Standard strike plates are 2-1/2" by 1-1/8". Door stop strike plates have an additional 3/8" lip for positive door stop. Alls trikeplates are made of hardened and plated steel to resist corrosion.

FINISHES Textured black pebble, satin chrome, bright chrome, nickle and satin nickle.

MODELS	A	B	C	D	E	F	G
8101 2-3/8" Backset	1-7/8"	5-3/8"	1"	1-1/2"	13/16"	3-3/8"	3-7/8"
8101OP 2-3/4" Backset	1-7/8"	5-3/8"	1"	1-7/8"	13/16"	3-3/4"	4-1/4"
8102LT, 8200 3" Backset	1-7/8"	5-3/8"	1"	2-1/16"	13/16"	3-15/16"	4-1/2"

A = Lock Opening Width

B = Lock Opening Height

C = Bolt Housing Opening Diameter

D = Distance From Edge of Door to Closest Edge of Lock Opening

E = Distance From Bottom of Lock Opening to Centerline of Bolt Housing

F = Distance From Edge of Door to Farthest Edge of Lock Open

G = Distance From Edge of Door to Farthest Edge of Lock Cover

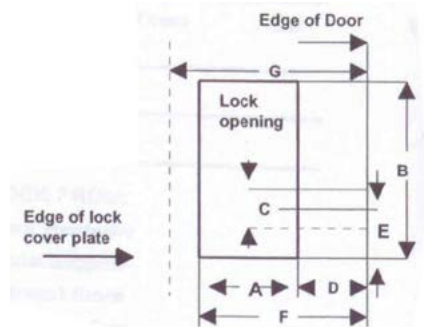

- **Exploded Parts Diagram**

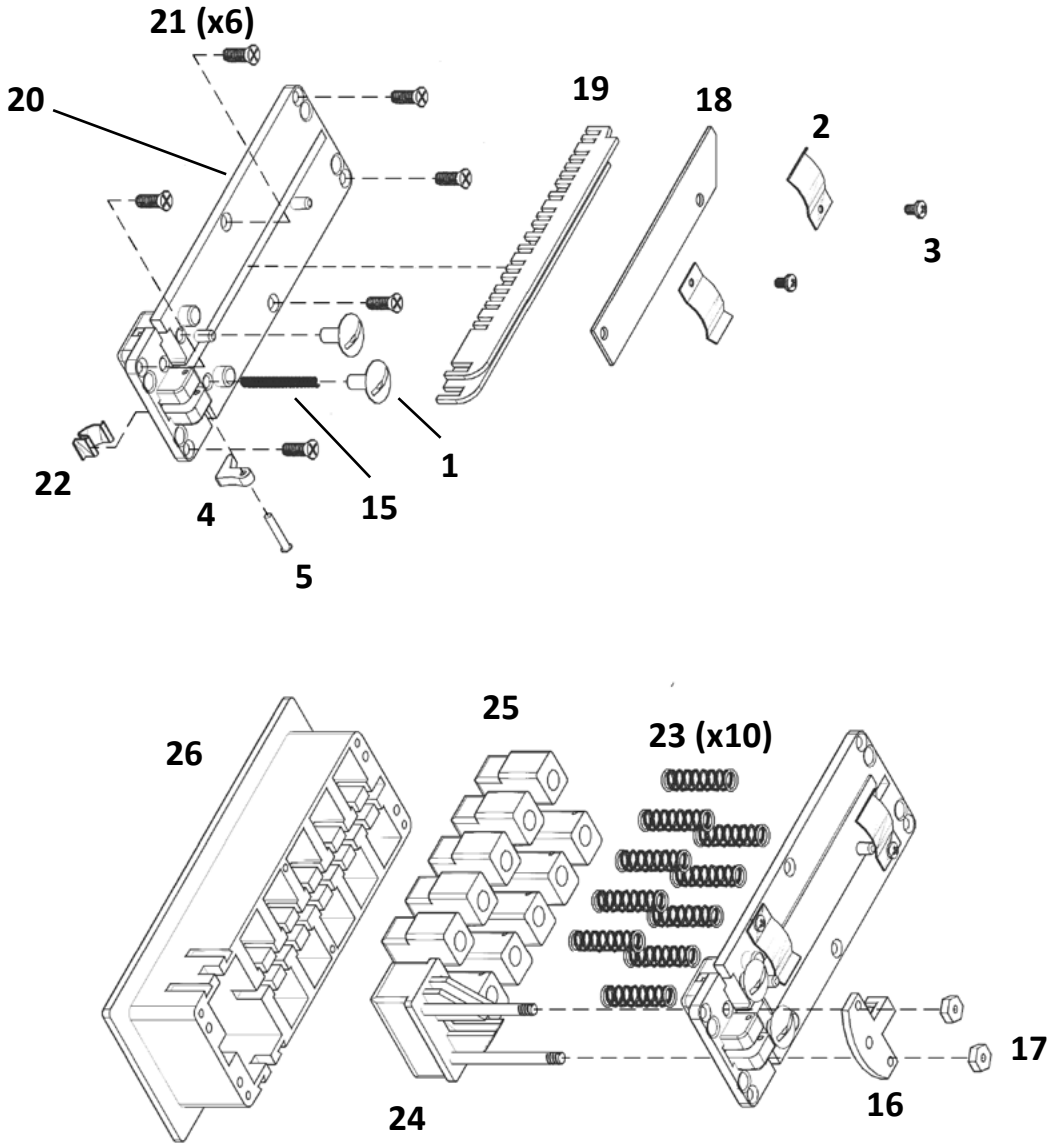

● Exploded Parts Continued

1. Large Flathead Screw (2)
2. Spring Clips (2)
3. Spring Clip Screws (2)
4. Unlock Lever
5. Unlock Lever Pin
6. Cotter Key
7. Rocker Arm Return Spring
8. Rocker Arm
9. Rocker Arm Pivot Clip
10. Unlock Button Flat Spring
11. Interior Unlock Button
12. Interior Lock Button
13. Interior Cover Plate
14. Interior Cover Plate Screws (4)
15. Reset Spring
16. Pull Plate
17. Pull Plate Nuts
18. Combination Slide Cover Plate
19. Combination Slides
20. Lock Body Cover Plate
21. Lock Body Cover Screws (6)
22. Neutralizing Spring
23. Number Button Springs (10)
24. Reset Button
25. Number Buttons
26. Lock Body

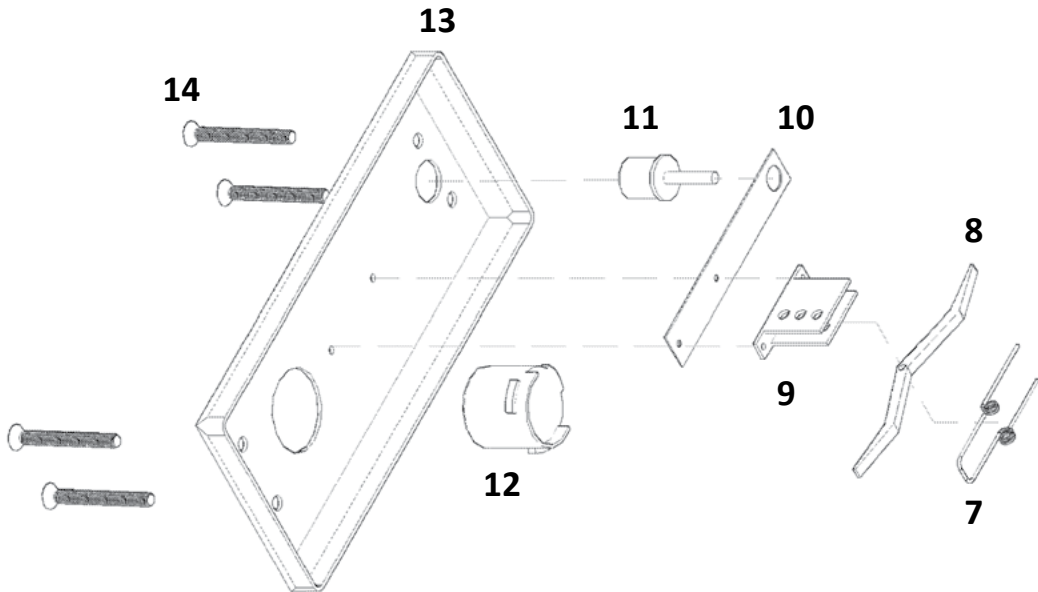

Note: Parts 16, 13, 12, and 11 are present only on models that have the nightlatch feature.