



3 FT POWER CORD ARE SUPPLIED WITH 1.5 kW (115V) & 2 kW (230V) HEATERS ONLY

NOTE: IT IS RECOMMENDED THAT ALL HEATERS LARGER THAN 2 KW BE HARD WIRED TO THE ELECTRICAL SUPPLY BY A QUALIFIED ELECTRICIAN.

-  1.5 KW HEATERS SUPPLIED WITH #5-20P 115V PLUG
-  2 KW HEATERS SUPPLIED WITH #6-15P 220V PLUG

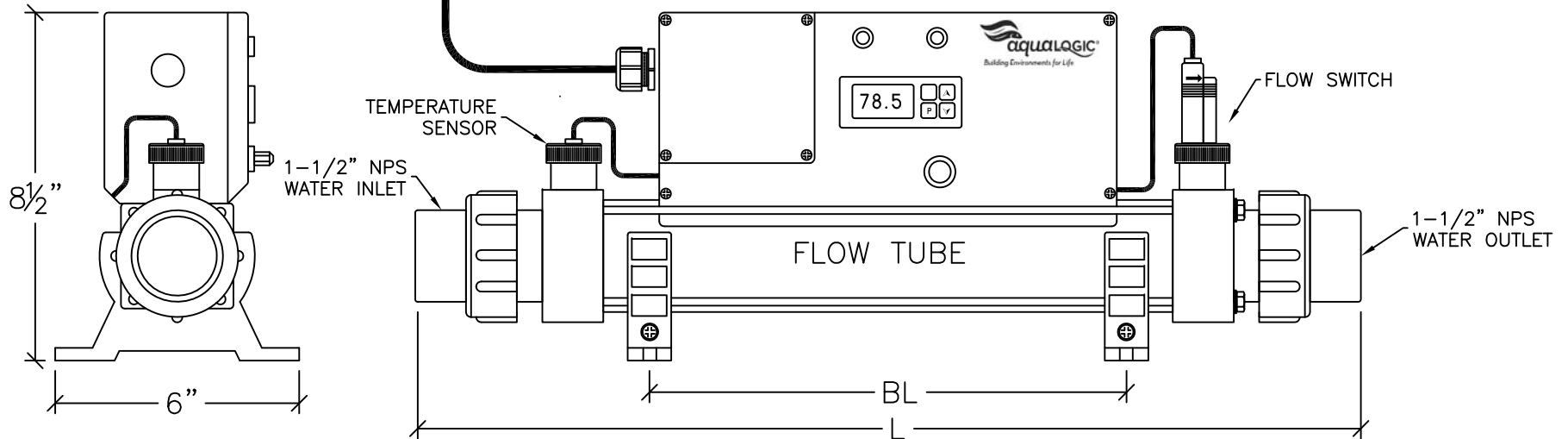

INLINE HEATER SPECIFICATIONS

MODEL	KW	VOLTS	PHASE	AMPS	L	BL
HSS-1.5-115	1.5	115	1	13	23"	12.5"
HSS-2-115	2	115	1	17.4	23"	12.5"
HSS-2-220	2	220	1	9	23"	12.5"
HSS-3-220	3	220	1	13.6	23"	12.5"
HTI-1.5-115	1.5	115	1	13	23"	12.5"
HTI-2-115	2	115	1	17.4	23"	12.5"
HTI-2-220	2	220	1	9	23"	12.5"
HTI-3-220	3	220	1	13.6	23"	12.5"
HTI-4-220	4	220	1	18	23"	12.5"
HTI-6-220	6	220	1	27	23"	12.5"
HTI-6-220-3	6	220	3	15.7	27"	16.5"
HTI-8-220	8	220	1	36.4	27"	16.5"
HTI-8-220-3	8	220	3	21	29.5"	16.5"
HTI-12-220	12	220	1	55	29.5"	16.5"
HTI-12-220-3	12	220	3	32	29.5"	16.5"
HTI-15-220-3	15	220	3	40	29.5"	16.5"
HTI-18-220-3	18	220	3	48	29.5"	16.5"

HSS- 316 STAINLESS STEEL MODELS
 HTI- PURE TITANIUM MODELS
 HEATERS USE DELTA 3 PHASE POWER

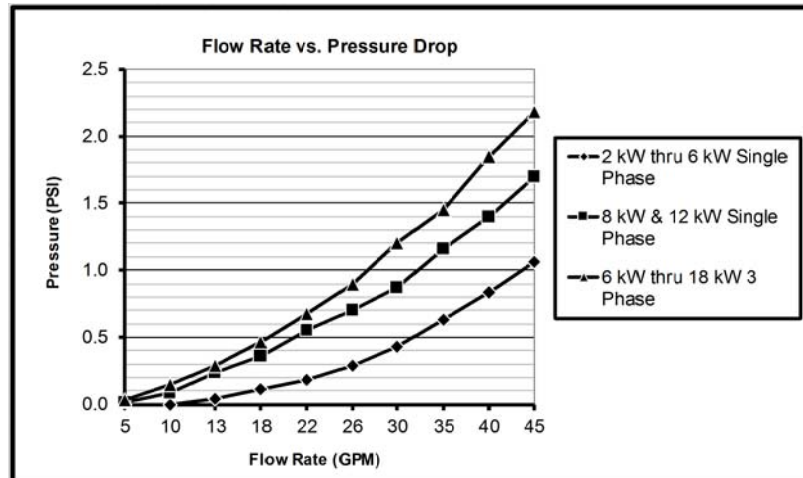

MINIMUM WATER FLOW RATE FOR 1.5 kW THRU 8 kW HEATERS: 10 GPM (600 GPH)
 MINIMUM WATER FLOW RATE FOR 12 kW THRU 18 kW HEATERS: 25 GPM (1500 GPH)
 MAXIMUM WATER FLOW RATE FOR ALL HEATERS: 44 GPM (2640 GPH)

 Aqua Logic, Inc.
 8268 Clairemont Mesa Blvd. Suite 302
 San Diego, CA 92111

TITLE: 1.5 KW THRU 18 KW
 INLINE HEATERS

LAST UPDATE: 3-7-14	DATE: 7-25-07	FILE: ELECRO HEATER	BY: CE
---------------------	---------------	---------------------	--------