

**MODELS (V)LVFO43NE AND
(V)LVFO43PE**

⚠ WARNING: If the information in this manual is not followed exactly, a fire or explosion may result causing property damage, personal injury or loss of life.

- Do not store or use gasoline or other flammable vapors and liquids in the vicinity of this or any other appliance.
- **WHAT TO DO IF YOU SMELL GAS**
 - Do not try to light any appliance.
 - Do not touch any electrical switch; do not use any phone in your building.
 - Immediately call your gas supplier from a neighbor's phone. Follow the gas supplier's instructions.
 - If you cannot reach your gas supplier, call the fire department.
- Installation and service must be performed by a qualified installer, service agency or the gas supplier.

⚠ WARNING: For Outdoor Use Only.

INSTALLER: Leave this manual with the appliance.
CONSUMER: Retain this manual for future reference.

TABLE OF CONTENTS

Safety	2	Wiring Diagram	20
Local Codes	4	Troubleshooting	21
Product identification	4	Parts	24
Product Features	4	Specifications	27
Installation	5	Replacement Parts	27
Operation	16	Service Hints	27
Cleaning and Maintenance	18	Technical Service	27
Inspecting Burners	19	Accessories	27
Replacing Light Bulb	19	Warranty	Back Cover

SAFETY

⚠ WARNING: Improper installation, adjustment, alteration, service or maintenance can cause injury or property damage. Refer to this manual for correct installation and operational procedures. For assistance or additional information consult a qualified installer, service agency or the gas supplier.

* Aftermarket: Completion of sale, not for purpose of resale, from the manufacturer

⚠ WARNING: This product contains and/or generates chemicals known to the State of California to cause cancer or birth defects or other reproductive harm.

IMPORTANT: Read this owner's manual carefully and completely before trying to assemble, operate or service this fireplace. Improper use of this fireplace can cause serious injury or death from burns, fire, explosion, electrical shock and carbon monoxide poisoning.

⚠ DANGER: Carbon monoxide poisoning may lead to death!

Carbon Monoxide Poisoning: Early signs of carbon monoxide poisoning resemble the flu, with headaches, dizziness or nausea. If you have these signs, the fireplace may not be working properly. **Get fresh air at once!** Have heater serviced. Some people are more affected by carbon monoxide than others. These include pregnant women, people with heart or lung disease or anemia, those under the influence of alcohol and those at high altitudes.

Natural and Propane/LP Gas: Natural and propane/LP gases are odorless. An odor-making agent is added to the gas. The odor helps you detect a gas leak. However, the odor added to the gas can fade. Gas may be present even though no odor exists.

Make certain you read and understand all warnings. Keep this manual for reference. It is your guide to safe and proper operation of this fireplace.

⚠ WARNING: Any change to this fireplace or its controls can be dangerous.

Due to high temperatures, the appliance should be located out of traffic and away from furniture and draperies.

Do not place clothing or other flammable material on or near the appliance. Never place any objects on the fireplace.

SAFETY

Continued

Fireplace become very hot when in use. Keep children and adults away from hot surfaces to avoid burns or clothing ignition. Fireplace will remain hot for a time after shutdown. Allow surfaces to cool before touching.

Carefully supervise young children when they are in the room with fireplace. When using the remote control, keep selector switch in the OFF position to prevent children from turning on burners with remote.

Keep the appliance area clear and free from combustible materials, gasoline and other flammable vapors and liquids.

The finish of the front face is protected with a self adhering plastic coating that must be removed before fireplace is operated. To prevent melting, ensure that the plastic coating protecting the finish is removed.

1. This appliance is only for use with the type of gas indicated on the rating plate. This appliance is not convertible for use with other gases.
2. Do not place propane/LP supply tank(s) inside any structure. Locate propane/LP supply tank(s) outdoors (propane/LP units only).
3. If you smell gas
 - shut off gas supply
 - do not try to light any appliance
 - do not touch any electrical switch; do not use any phone in your building
 - immediately call your gas supplier from a neighbor's phone. Follow the gas supplier's instructions
 - if you cannot reach your gas supplier, call the fire department
4. This fireplace shall be used only outdoors in a well ventilated space and shall not be used in a building, garage or any other enclosed area.
5. Do not use this fireplace as a wood-burning fireplace. Use only high temperature pebbles that are approved for use with this fireplace.
6. To prevent the creation of soot, follow the instructions in *Cleaning and Maintenance*, page 18.
7. Before using furniture polish, wax, carpet cleaner or similar products, turn fireplace off. If heated, the vapors from these products may create a white powder residue within burner box or on adjacent walls or furniture.
8. Do not run fireplace
 - where flammable liquids or vapors are used or stored
 - under dusty conditions
9. Do not use this fireplace to cook food or burn paper or other objects.
10. Do not use fireplace if any part has been exposed to or under water. Immediately call a qualified service technician to inspect the fireplace and to replace any part of the control system and any gas control which has been under water.
11. Turn fireplace off and let cool before servicing. Only a qualified service person should service and repair fireplace.
12. To prevent performance problems in propane/LP units, do not use propane/LP fuel tanks of less than 100 lbs. capacity (propane/LP units only).
13. Provide adequate clearances around air openings.

SAFETY

Continued

LOCAL CODES

Install and use fireplace with care. Follow all local codes. In the absence of local codes, use the latest edition of *The National Fuel Gas Code ANSI Z223.1/NFPA 54**.

*Available from:

American National Standards Institute, Inc.
1430 Broadway
New York, NY 10018

National Fire Protection Association, Inc.
Batterymarch Park
Quincy, MA 02269

State of Massachusetts: The installation must be made by a licensed plumber or gas fitter in the Commonwealth of Massachusetts.

Sellers of unvented propane or natural gas-fired supplemental room heaters shall provide to each purchaser a copy of 527 CMR 30 upon sale of the unit.

Vent-free gas products are prohibited for bedroom and bathroom installation in the Commonwealth of Massachusetts.

PRODUCT IDENTIFICATION

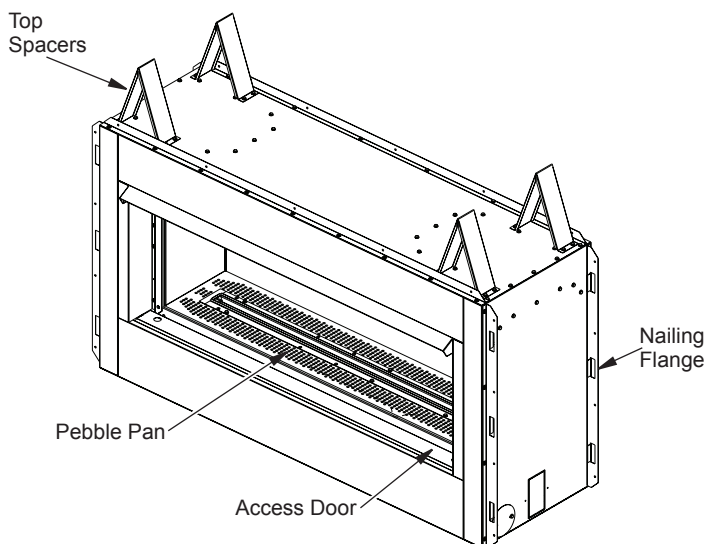

Figure 1 - Outdoor Linear Fireplace

PRODUCT FEATURES

OPERATION

This fireplace is clean burning. It requires no outside venting. There is no heat loss out a vent or up a chimney. Heat is generated by realistic flames. This fireplace is designed for outdoor use only. It has been tested and approved to ANSI Z21.97 standard for

outdoor decorative gas appliance and CAN 1-2.21-M85 standard for gas-fired appliance for outdoor installation.

INSTALLATION

⚠ CAUTION: This fireplace creates warm air currents. These currents move heat to wall surfaces next to fireplace. Installing fireplace next to vinyl or cloth wall coverings or operating fireplace where impurities (such as, but not limited to, tobacco smoke, aromatic candles, cleaning fluids, oil or kerosene lamps, etc.) in the air exist, may discolor walls or cause odors.

Note: Standoff spacers are attached to the sides and top of your fireplace, these spacers can be placed directly against wall or framing materials.

IMPORTANT: Make sure fireplace is level. If fireplace is not level, burner will not work properly. Use dimensions shown for rough openings to create the easiest installation (see Figures 2 thru 5, page 6).

CHECK GAS TYPE

Use the correct gas type (natural or propane/LP) for your fireplace. If your gas supply is not correct, do not install fireplace. Call dealer where you bought fireplace for proper type gas.

⚠ WARNING: This appliance is equipped for either natural gas or propane/LP gas but not both. Gas type is indicated on the rating plate. Field conversion is not permitted.

INSTALLATION CLEARANCES

⚠ WARNING: Maintain the minimum clearances. If you can, provide greater clearances from floor, ceiling and adjoining wall.

Carefully follow the instructions below. This will ensure safe installation.

CLEARANCES

Minimum clearances to combustibles for the fireplace are as follows:

*Back and sides	1"
Perpendicular walls	8"
Floor (From bottom of Fireplace)	0"
Ceiling (From top of opening)	42"
Top of Standoffs	0"

* For back and sides of fireplace, do not pack with insulation or other materials.

OUTDOOR ENCLOSURE REQUIREMENTS

Must conform to one of the following conditions:

- With walls on all sides, but with no overhead cover;
- Within a partial enclosure which includes an overhead cover and no more than two side walls. These side walls may be parallel, as in breezeway or at right angles to each side; or
- Within a partial enclosure which includes an overhead cover and three sidewalls, as long as 30% or more of the horizontal periphery of the enclosure is permanently open.

FRAMING AND FINISHING

Figure 2 page 6 shows typical framing of this fireplace. Figure 3 page 6 shows framing for see-thru installation. All minimum clearances must be met. Steel framing may be necessary or wood studs may be notched. Concrete board is provided for facing around the fireplace as shown in Figure 4 page 6.

If you are using a separate combustible mantel piece, refer to Figure 5, page 6 for proper installation height. You can install noncombustible mantels at any height above the fireplace.

Note: Noncombustible mantels may discolor!

INSTALLATION

Continued

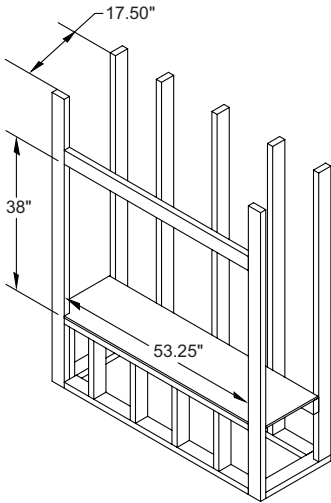

Figure 2 - Framing Clearances for One Sided Application

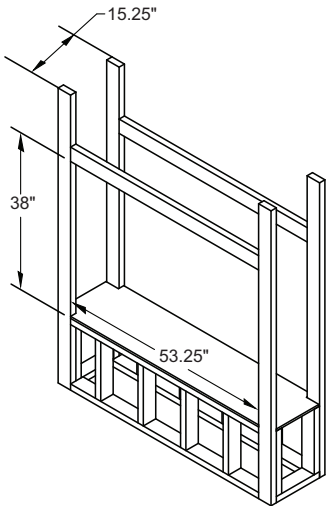

Figure 3 - Framing Clearances for See-Thru Application

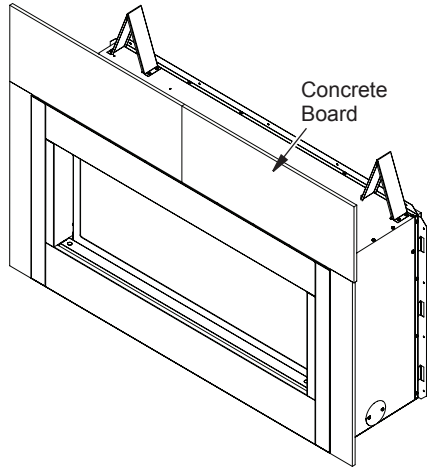

Figure 4 - Installing Concrete Board

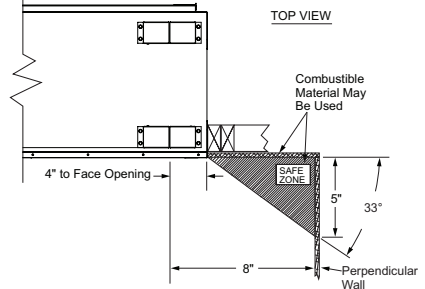
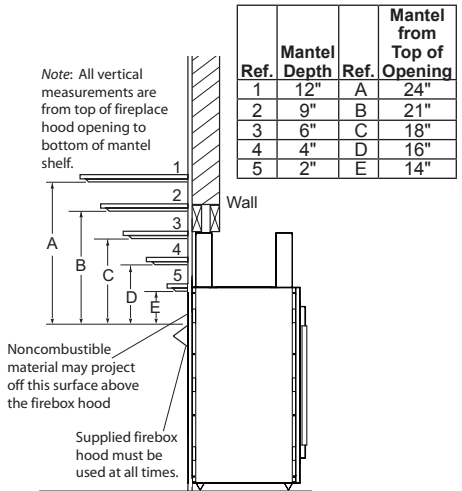

Figure 5 - Clearances for Combustible Mantels

INSTALLATION

Continued

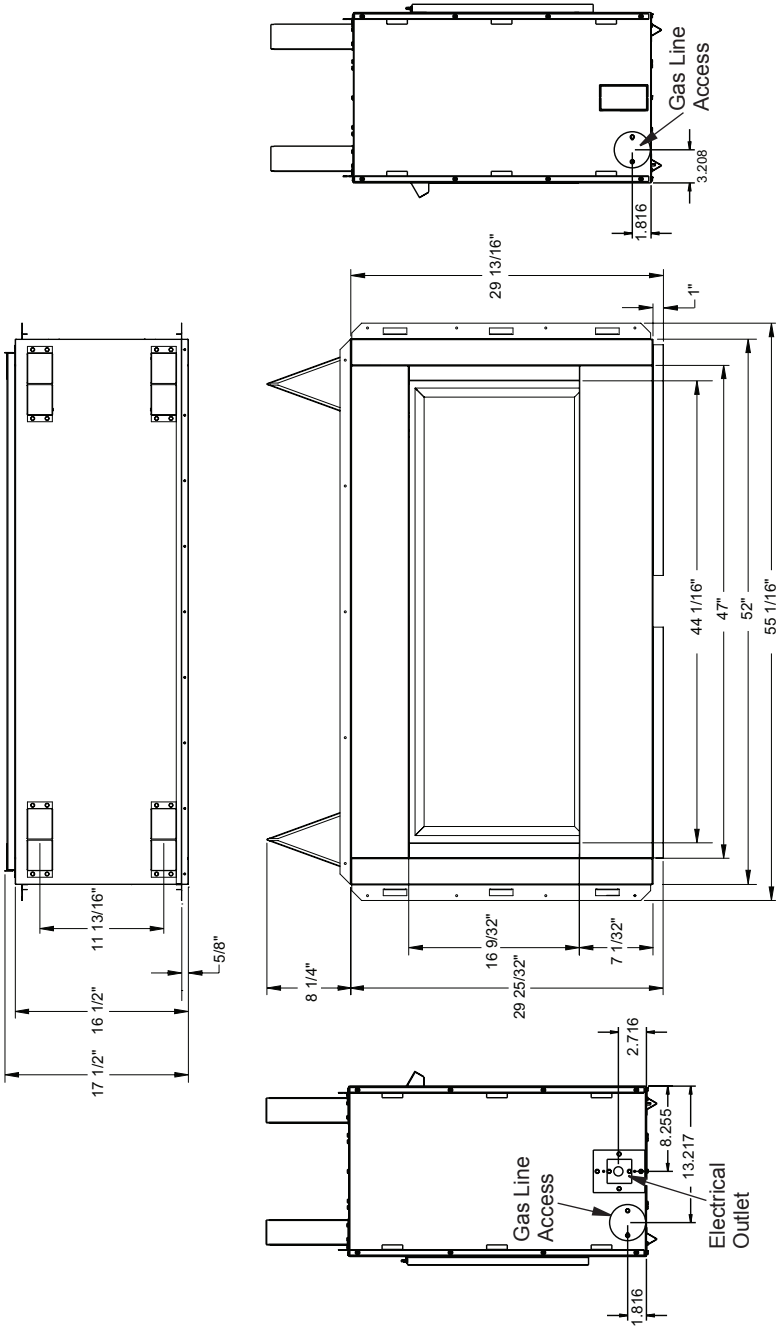

Figure 6 - (V)LVFO43E Series Dimensions

INSTALLATION

Continued

Mantel Clearances for Built-In Installation

If placing mantel above built-in fireplace, you must meet minimum clearance between mantel shelf and top of fireplace opening.

NOTICE: If your installation does not meet the minimum clearances shown, you must do one of the following:

- raise the mantel to an acceptable height
- remove the mantel

NOTICE: Surface temperatures of adjacent walls and mantels become hot during operation. Walls and mantels above the firebox may become hot to the touch. If installed properly, these temperatures meet the requirement of the national product standard. Follow all minimum clearances shown in this manual.

ELECTRICAL WIRING INSTRUCTIONS

1. Remove electrical cover plate with bushing from left side of fireplace front by removing 2 sheet metal screws as shown in Figure 7.
2. Slide power source wiring through electrical bushing opening and electrical cover plate and make all necessary connections.
3. Slide all wiring connections in electrical housing as shown in Figure 7.
4. Secure electrical cover plate with screws previously removed.

Note: Electrical housing and cover plate have sharp edges. Wear protective gloves.

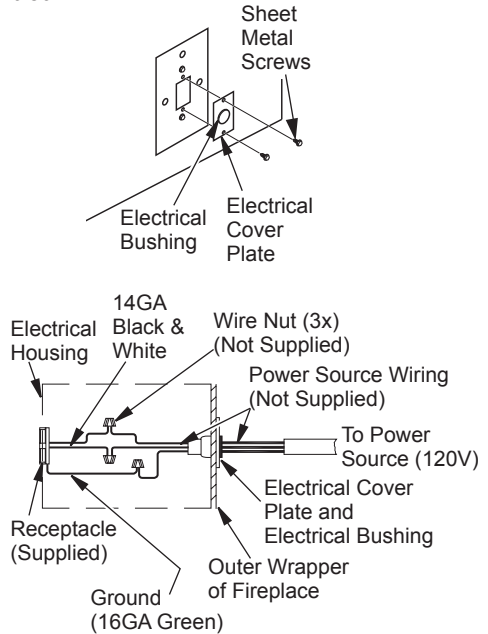

Figure 7 - Connecting Electricity

CHECK GAS TYPE

Use proper gas type for the fireplace unit you are installing. If you have conflicting gas types, do not install fireplace. See retailer where you purchased the fireplace for proper fireplace according to your gas type.

INSTALLING GAS PIPING TO FIREPLACE LOCATION

WARNING: A qualified service person must connect fireplace to gas supply. Follow all local codes.

CAUTION: Never connect propane/LP fireplace directly to the propane/LP supply. This fireplace requires an external regulator (not supplied). Install the external regulator between the fireplace and propane/LP supply.

INSTALLATION

Continued

⚠ WARNING: Never connect natural gas fireplace to private (non-utility) gas wells. This gas is commonly known as wellhead gas.

Installation Items Needed

Before installing fireplace, make sure you have the items listed below.

- external regulator for propane/LP unit only (supplied by installer)
- piping (check local codes)
- sealant (resistant to propane/LP gas)
- equipment shutoff valve *
- test gauge connection *
- sediment trap (optional)
- tee joint
- pipe wrench
- approved flexible gas line with gas connector (if allowed by local codes) (not provided)

* An equipment shutoff valve with 1/8" NPT tap is an acceptable alternative to test gauge connection. Purchase the optional equipment shutoff valve from your dealer.

For propane/LP units, the installer must supply an external regulator. The external regulator will reduce incoming gas pressure. You must reduce incoming gas pressure to between 11" and 14" of water. If you do not reduce incoming gas pressure, fireplace regulator damage could occur. Install external regulator with the vent pointing down as shown in Figure 8. Pointing the vent down protects it from freezing rain or sleet.

⚠ CAUTION: Use only new, black iron or steel pipe. Internally-tinned copper tubing may be used in certain areas. Check your local codes. Use pipe of 1/2" diameter or greater to allow proper gas volume to fireplace. If pipe is too small, undue loss of volume will occur.

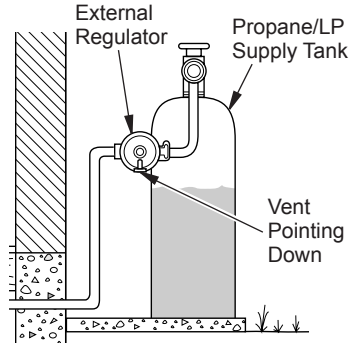

Figure 8 - External Regulator on Propane/LP Supply Tank with Vent Pointing Down

Installation must include an equipment shutoff valve, union and plugged 1/8" NPT tap. Locate NPT tap within reach for test gauge hook up. NPT tap must be upstream from fireplace (see Figure 8).

IMPORTANT: Install equipment shutoff valve in an accessible location. The equipment shutoff valve is for turning on or shutting off the gas to the appliance.

Check your building codes for any special requirements for locating equipment shutoff valve to fireplaces.

Apply pipe joint sealant lightly to male NPT threads. This will prevent excess sealant from going into pipe. Excess sealant in pipe could result in clogged fireplace valves. Never use sealant on flare threads.

⚠ WARNING: Use pipe joint sealant that is resistant to liquid petroleum (LP) gas.

We recommend that you install a sediment trap in supply line as shown in Figure 9, page 10. Locate sediment trap where it is within reach for cleaning. Install in piping system between fuel supply and fireplace. Locate sediment trap where trapped matter is not likely to freeze. A sediment trap traps moisture and contaminants. This keeps them from going into fireplace gas controls. If sediment trap is not installed or is installed wrong, fireplace may not run properly.

INSTALLATION

Continued

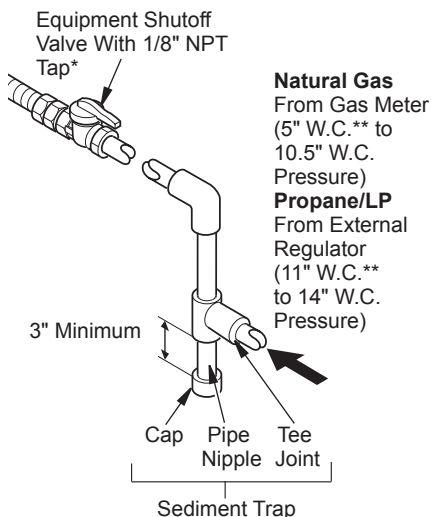

Figure 9 - Gas Connection

* Purchase the optional equipment shutoff valve from your dealer.

** Minimum inlet pressure for purpose of input adjustment.

CONNECTING FIREPLACE TO GAS SUPPLY

Installation Items Needed

- 5/16" hex socket wrench or nut-driver
- sealant (resistant to propane/LP gas, not provided)

1. Route flexible gas line (provided by installer) from equipment shutoff valve to fireplace. Route flexible gas supply line through one of the access holes on side of fireplace.
2. Attach flexible gas line from gas supply to control valve (see Figure 10).
3. Check all gas connections for leaks. See Checking Gas Connections.

CHECKING GAS CONNECTIONS

WARNING: Test all gas piping and connections, internal and external to unit, for leaks after installing or servicing. Correct all leaks at once.

WARNING: Never use an open flame to check for a leak. Apply a noncorrosive leak detection fluid to all joints. Bubbles forming show a leak. Correct all leaks at once.

CAUTION: Make sure external regulator has been installed between propane/LP supply and fireplace. See guidelines under Connecting Fireplace to Gas Supply.

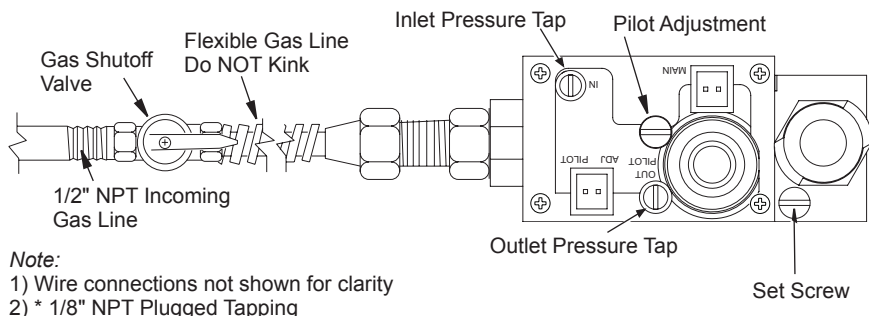

Note:

- 1) Wire connections not shown for clarity
- 2) * 1/8" NPT Plugged Tapping

Figure 10 - Connecting Incoming Gas Line to Flex Gas Line

INSTALLATION

Continued

PRESSURE TESTING GAS SUPPLY PIPING SYSTEM

Test Pressures In Excess Of 1/2 PSIG (3.5 kPa)

1. Disconnect fireplace with its appliance main gas valve (control valve) and equipment shutoff valve from gas supply piping system. Pressures in excess of 1/2 psig will damage fireplace regulator.
2. Cap off open end of gas pipe where equipment shutoff valve was connected.
3. Pressurize supply piping system by either opening propane/LP supply tank valve for propane/LP gas or opening main gas valve located on or near gas meter for natural gas or using compressed air.
4. Check all joints of gas supply piping system. Apply noncorrosive leak detection fluid to all joints. Bubbles forming show a leak.
5. Correct all leaks at once.
6. Reconnect fireplace and equipment shutoff valve to gas supply. Check reconnected fittings for leaks.

Test Pressures Equal To or Less Than 1/2 PSIG (3.5 kPa)

1. Close equipment shutoff valve (see Figure 11).
2. Pressurize supply piping system by either opening propane/LP supply tank valve for propane/LP gas or opening main gas valve located on or near gas meter for natural gas or using compressed air.
3. Check all joints from gas meter to equipment shutoff valve for natural gas or propane/LP supply to equipment shutoff valve for propane/LP (see Figures 12 or 13). Apply noncorrosive leak detection fluid to all joints. Bubbles forming show a leak.
4. Correct all leaks at once.

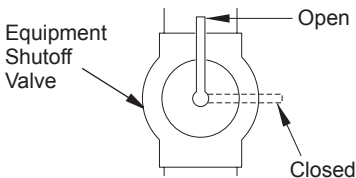

Figure 11 - Equipment Shutoff Valve

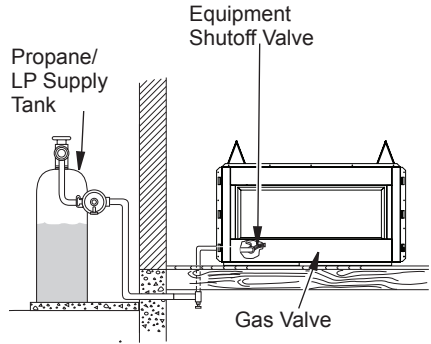

Figure 12 - Checking Gas Joints for Propane/LP Gas Fireplace

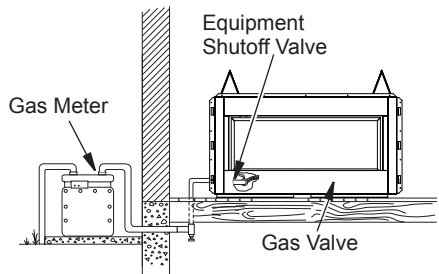

Figure 13 - Checking Gas Joints for Natural Gas Fireplace

PRESSURE TESTING FIREPLACE GAS CONNECTIONS

1. Open equipment shutoff valve (see Figure 11).
2. Open main gas valve located on or near gas meter for natural gas or open propane/LP supply tank valve.
3. Make sure control knob of fireplace is in the OFF position.
4. Check all joints from equipment shutoff valve to gas control valve (see Figures 12 or 13). Apply noncorrosive leak detection fluid to all joints. Bubbles forming show a leak.
5. Correct all leaks at once.
6. Light fireplace (see *Operation*, page 16). Check all other internal joints for leaks.
7. Turn off fireplace (see *To Turn Off Gas to Appliance*, page 17).

INSTALLATION

Continued

FINISHING FIREPLACE FOR INSTALLATION

(V)LVFO43 series fireplace come with the rear panel semi-installed. If you will be using the fireplace for a one sided regular application, you will need to finish the installation of the rear panel. If you will be upgrading the fireplace to a see-thru, the rear panel will need to be removed (See *Upgrading (V)LVFO43 Series to See-Thru Application*).

1. Using self-tapping screws provided and holes on rear panel as a guide, screw the rear panel to the fireplace as shown in Figure 14.

INSTALLING HOOD

1. Loosen screws at top of face opening and slide hood through screws as shown in Figure 15.
2. Tighten screws securing hood to fireplace.

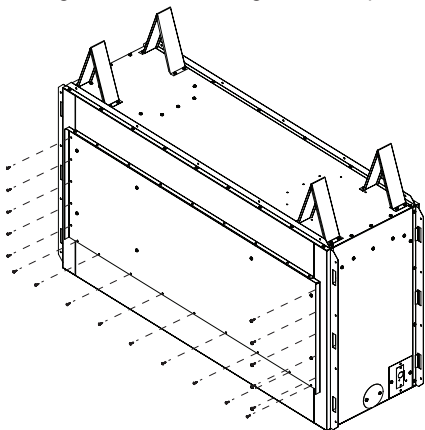

Figure 14 - Installing Rear Panel for Regular Applications

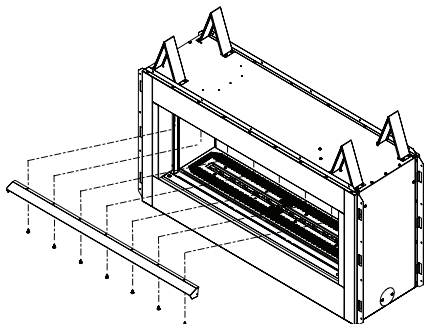

Figure 15 - Installing Hood

UPGRADING (V)LVFO43 TO SEE-THRU APPLICATION

Removing Rear Panel

1. In the rear of the fireplace, locate screws at top of rear panel and remove as shown in Figure 16. Discard screws and rear panel.
2. Unscrew mount bracket from top face as shown in Figure 17. Discard mounting bracket and replace screws.

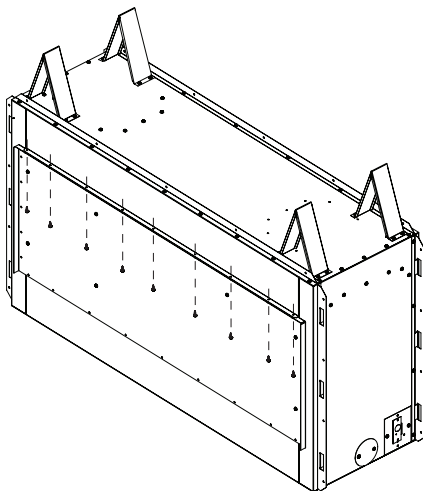

Figure 16 - Removing Rear Panel for See-Thru Applications

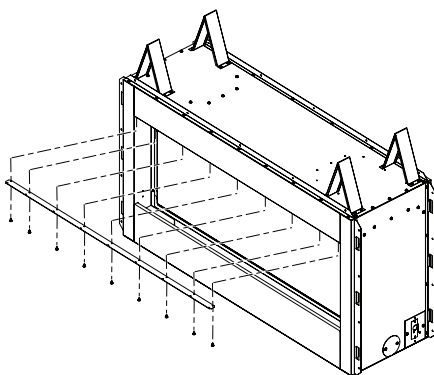

Figure 17 - Removing for See-Thru Applications

INSTALLATION

Continued

Removing False Door

1. In the rear of the fireplace, Unlock 3 door latches on top of firebox using your fingers or the latch opener provided.
2. Hook opener over latch as shown in Figure 18. Swing the bottom of the opener down toward the door. You will not need to pull down.
3. Tilt open false door 45° from the top of firebox and lift up to release door from retaining channel.

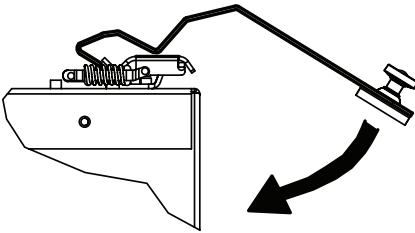

Figure 18 - Latch Opener

Removing Rear Interior Wall

1. Through firebox opening in the front of the fireplace, unscrew 4 corner brackets from the firebox top (See Figure 19).
2. Remove 2 side walls and then the rear wall. Discard rear wall.
3. Replace 2 side walls and reinstall the corner brackets.

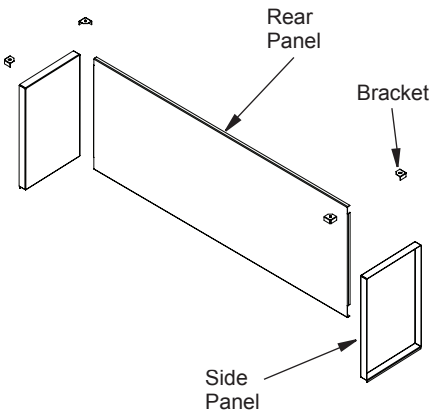

Figure 19 - Removing Rear Interior Wall for See-Thru Applications

Installing Access Door Retaining Brackets

1. Screw access door retaining brackets into the inner side face using 2 screws on both the left and right side as shown in Figure 20.

Installing Side Face Filler

1. Screw side face filler into firebox side baffle using 2 screws on both the left and right side as shown in Figure 21.

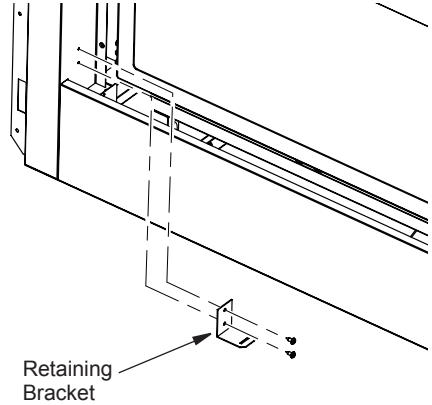

Figure 20 - Installing Access Door Retaining Brackets for See-Thru Applications

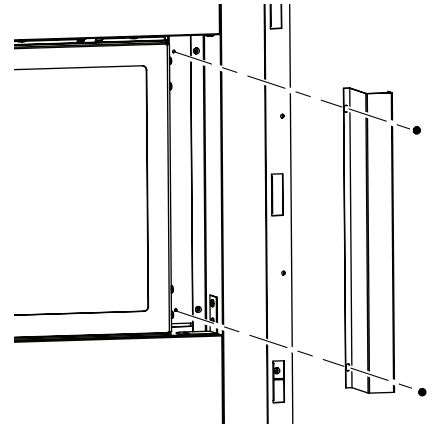

Figure 21 - Installing Side Face Filler for See-Thru Applications

INSTALLATION

Continued

Installing Access Door

1. Place access door into rectangular opening in front of the glass door with the slanted side facing forward. The slanted surface will slide underneath the flange of the bottom face. Insert tabs on side of access door into slots on retaining brackets (See Figure 22).

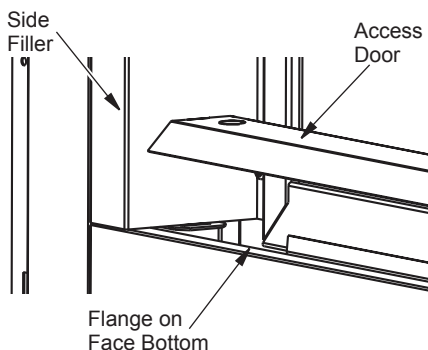

Figure 22 - Access Door for See-Through Applications

Installing Hood

1. Install hood as shown on page 12.

Locating Control Module

1. Remove Access Plate (See Figure 22).
2. Remove 2 screws on top of the electronic access cover (See Figure 23).
3. Remove electronic access cover by gently pulling up and out of the fireplace. There are two switches connected to cover.
4. The control module is located on the left as shown in Figure 24.

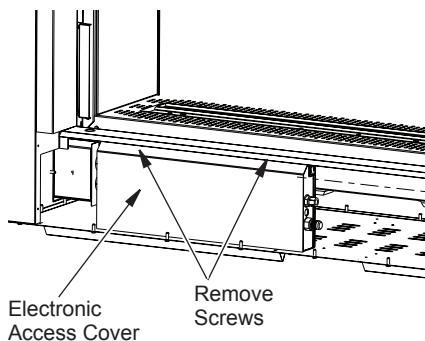

Figure 23 - Removing Control Access Cover (Face Bottom not shown for Clarity)

5. Light switch is located on the right hand side as shown in Figure 24.
6. ON/OFF switch is located on the left hand side as shown in Figure 24.

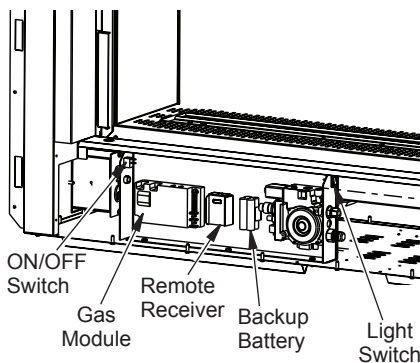

Figure 24 - Control Module (Face Bottom not shown for Clarity)

GLASS PEBBLE INSTALLATION

⚠ WARNING: Do not change or substitute glass pebbles provided with this fireplace. If replacing, use only replacement glass pebbles. See Replacement Parts page 27.

Green glass pebbles are included with your fireplace.

1. Place glass pebbles in a single layer evenly on the pebble pan. Make sure not to place any on the burner in the center of the pebble pan.

INSTALLATION

Continued

GLASS PANEL INSTALLATION

The glass panel assembly should be installed after the fireplace is completely framed and finished. The brackets are attached to the front side face of the fireplace using two screws as shown in Figure 25. Position the glass panel in the bracket so that it is securely in place. The glass panel can be placed in two different height locations.

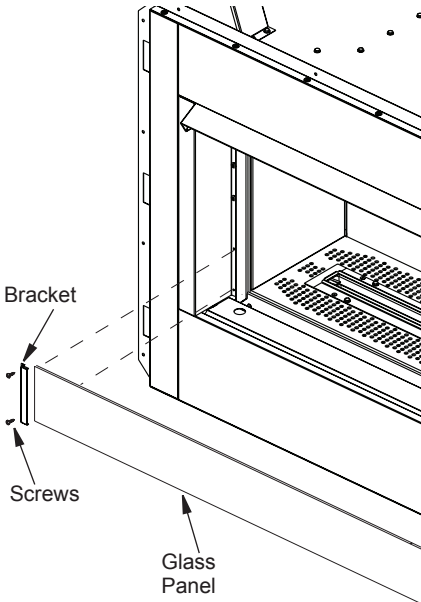

Figure 25 - Installing Glass Panel

GAS CONTROL MODULE SYSTEM REMOTE CONTROL FEATURE

The module has a built in remote control receiver that allows the user to program the remote transmitter at any time during or after the installation of the burner.

1. There is a switch located on the right side of the module that reads REMOTE/OFF (Figure 26).
2. When the remote/off switch is in the OFF position, the burner will operate from the rocker switch or wall switch connected to the two BROWN wires on the module.
3. When the remote/off is in the REMOTE position the burner will operate from the Remote Control Transmitter.

NOTE: The module must be programmed to the Remote Control Transmitter.

- To program the module (make sure the system has power), locate the learn button (Figure 27) on the module. Locate the metal shield that is covering the module and remove the screw on top. Use a small thin object like a paper clip (not sharp points) to press and release the learn button. There will be a beep sound from the module. Then press any button on the remote transmitter. Once the module's internal receiver accepts the transmitter code, there will be a series of confirming beeps.
- The remote system is ready for use.
- Pushing and holding the LEARN button for 6 seconds will result in clearing the transmitter security code from the module's memory. The module will make three long beeps in succession when it has been cleared.

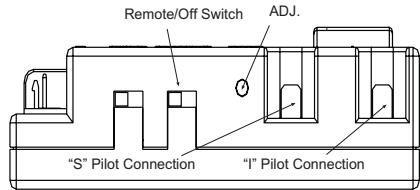

Figure 26 - Gas Module Right Side

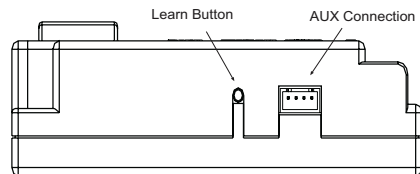

Figure 27 - Gas Module Left Side

INSTALLATION

Continued

IGNITOR ASSEMBLY

The ignitor assembly is factory preset for proper ignition of the burner. Alterations may have occurred during shipping and handling. Call a qualified service person to readjust the ignitor assembly if necessary.

The ignitor should be positioned as shown in Figure 28.

Note: Figure 28, shows the correct positioning of the ignitor and sensing rod.

If your ignitor assembly does not meet these requirements:

- turn appliance off (see *To Turn Off Gas to Appliance*, page 17).
- see *Troubleshooting*, page 18

Note: Reference only, not to scale

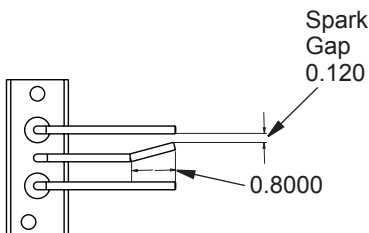
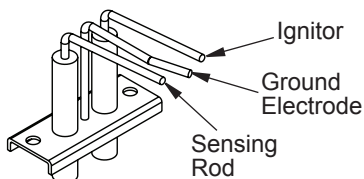

Figure 28 - Ignitor

OPERATION

**FOR YOUR SAFETY
READ BEFORE LIGHTING**

⚠ WARNING: If you do not follow these instructions exactly, a fire or explosion may result causing property damage, personal injury or loss of life.

- A. This appliance does not have a pilot, it is equipped with an ignition device which automatically lights the pilot. Do not light pilot by hand.
- B. **BEFORE LIGHTING** smell all around the appliance area for gas. Be sure to smell next to the floor because some gas is heavier than air and will settle on the floor.

WHAT TO DO IF YOU SMELL GAS



- Do not try to light any appliance.
 - Do not touch any electric switch; do not use any phone in your building.
 - Immediately call your gas supplier from a neighbor's phone. Follow the gas supplier's instructions.
 - If you cannot reach your gas supplier, call the fire department.
- C. Do not use this appliance if any part has been under water. Immediately call a qualified service technician to inspect the appliance and to replace any part of the control system and any gas control which has been under water.

OPERATION

Continued

LIGHTING INSTRUCTIONS

This appliance requires 120V electricity for normal operation. Control module should be plugged into electrical outlet located underneath firebox bottom. Back up battery supply is available for power outages.

1. STOP! Read the safety information, column 1.
2. Make sure equipment shutoff valve is fully open.
3. Turn safety shutoff switch to the OFF position.
4. Remove access cover.
5. Turn equipment shutoff valve clockwise  to the OFF position (see Figure 29). Do not force.
6. Wait five (5) minutes to clear out any gas. Then smell for gas, including near the floor. If you smell gas, STOP! Follow "B" in the safety information. If you don't smell gas, go to the next step.
7. Turn equipment shutoff valve counter-clockwise  to the ON position. Do not force.
8. Replace access cover.
9. Turn on all electric power to appliance.
10. Turn safety shutoff switch to the ON position.
11. Visually locate ignitor. Ignitor should begin to spark and main burner should ignite once flame appears at pilot.

- If lighting appliance for the first time each season, it may take several attempts before supply gas can reach pilot and main burners.
- If appliance will not stay lit after several attempts, follow instructions under To Turn Off Gas To Appliance and call your service technician or gas supplier.

⚠ CAUTION: Do not try to adjust heating levels by using the equipment shutoff valve.

TO TURN OFF GAS TO APPLIANCE

1. Push remote control to "OFF" position.
2. Turn off all electric power to appliance if service is to be performed.
3. Turn equipment shutoff valve clockwise  to OFF. Do not force.
4. Replace access cover.

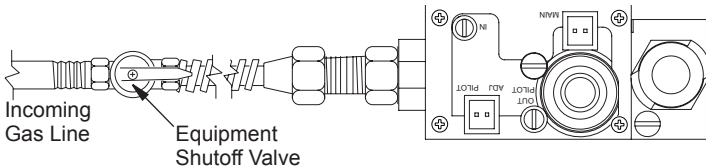

Figure 29 - Turning Equipment Shutoff Valve to the OFF Position

CLEANING AND MAINTENANCE

⚠ WARNING: Turn off fireplace and let cool before cleaning.

⚠ CAUTION: You must keep control areas, burner and circulating air passageways of fireplace clean. Inspect these areas of fireplace before each use. Have fireplace inspected yearly by a qualified service person.

⚠ WARNING: Failure to keep the primary air opening(s) of the burner(s) clean may result in sooting and property damage.

BURNER INJECTOR HOLDER AND PILOT AIR INLET HOLE

The primary air inlet holes allow the proper amount of air to mix with the gas. This provides a clean burning flame. Keep these holes clear of dust, dirt, lint and pet hair. Clean these air inlet holes prior to each heating season. Blocked air holes will create soot. We recommend that you clean the unit every three months during operation and have fireplace inspected yearly by a qualified service person.

We also recommend that you keep the burner tube and pilot assembly clean and free of dust and dirt. To clean these parts we recommend using compressed air no greater than 30 PSI. Your local computer store, hardware store or

home center may carry compressed air in a can. If using compressed air in a can, please follow the directions on the can. If you don't follow directions on the can, you could damage the ignitor.

1. Shut off the unit. Allow the unit to cool for at least thirty minutes.
2. Inspect burner, air shutter and orifice for dust and dirt (see Figure 30).
3. Blow air through the ports/slots and holes in the burner.
4. Check the orifice located at the end of the burner tube again. Remove any large particles of dust, dirt, lint or pet hair with a soft cloth or vacuum cleaner nozzle.
5. Blow air into the primary air holes on the injector holder.
6. In case any large clumps of dust have now been pushed into the burner repeat steps 3 and 4 above.

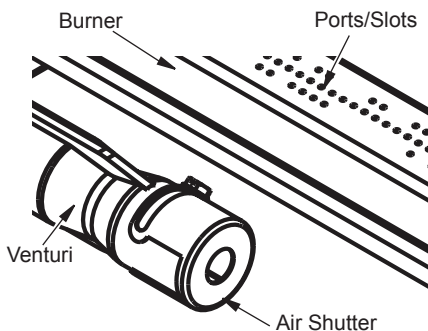

Figure 30 - Injector Holder On Outlet Burner Tube

INSPECTING BURNERS

BURNER PRIMARY AIR HOLES

Air is drawn into the burner through the holes in the fitting at the burner entrance. These holes may become blocked with dust or lint. Periodically inspect these holes for any blockage and clean if needed. Blocked air holes will create soot.

MAIN BURNER

Periodically inspect all burner flame holes with the fireplace running. Some burner flame holes may become blocked by debris or rust, with no flame present. If so, turn off fireplace and let cool. Remove blockage. Blocked burner flame holes will create soot.

BURNER FLAME PATTERN

 **WARNING: If yellow tipping occurs, your fireplace could produce increased levels of carbon monoxide.**

NOTICE: Do not mistake orange flames with yellow tipping. Dirt or other fine particles enter the fireplace and burn causing brief patches of orange flame.

Burner flames will be steady, not lifting or floating. Flame patterns will be different from unit to unit and will vary depending on installation type and weather conditions. This can be dangerous. Inspect flames after installation to ensure proper installation and performance. If burner flame pattern differs from that described:

- turn fireplace off (see [To Turn Off Gas to Appliance](#), page 17)
- see [Troubleshooting](#), page 21

REPLACING LIGHT BULB

Light assembly is located underneath the burner assembly (see page 24 for reference).

1. Unplug power supply.
2. Remove access door (Figure 22, page 14).
3. Remove glass panel if installed (Figure 25, page 15).
4. Remove rear interior panels (Figure 19, page 13).
5. Remove glass Pebbles.
6. Remove six screws holding the pebble pan (see item #17 on page 26 for reference).
7. Using a small slotted screw driver, carefully slide it under the edge of light bulb cover and pry it open. Pull burned out bulb and replace.
8. Replace all in reverse order.

WIRING DIAGRAM

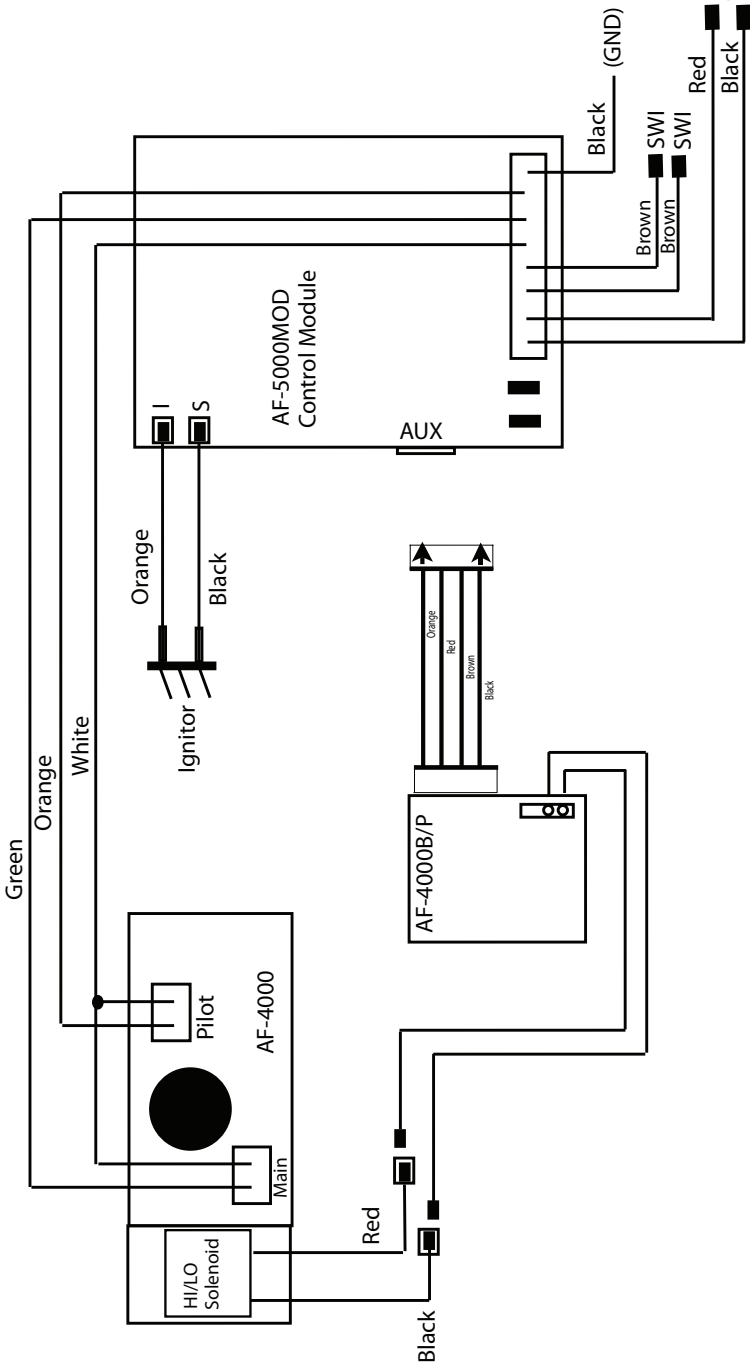

TROUBLESHOOTING



WARNING: Turn off appliance and let cool before servicing. Only a qualified service person should service and repair appliance.

Note: All troubleshooting items are listed in order of operation.

Remote Ignitor has a special feature. It will allow heat from the burner to dry the probe and burner assembly due to excess moisture, caused by rain, humidity or condensation. To activate:

- Press and hold the HI and LO buttons on the transmitter for 30-45 seconds. This allows the sparking to start and the burner to ignite.
- Release the HI and LO buttons, after the allotted time, sparking will stop and the burner will go out.
- Press and hold the ON button and sparking will start again and burner should ignite.
- Release the ON button. The sparking will stop, and the burner should stay ON.
- Repeat if necessary.

OBSERVED PROBLEM	POSSIBLE CAUSE	REMEDY
When "ON" button on remote control is pressed, there is no spark at ignitor assembly	<ol style="list-style-type: none"> 1. Ignitor electrode not connected to ignitor cable 2. Ignitor cable pinched or wet 3. Broken ignitor cable 4. Bad ignitor 5. Ignitor electrode positioned wrong 6. Ignitor electrode broken 7. Battery not installed, battery power low or battery not installed correctly (electronic ignition models only) 	<ol style="list-style-type: none"> 1. Reconnect ignitor cable 2. Free ignitor cable if pinched by any metal or tubing. Keep ignitor cable dry 3. Replace ignitor 4. Replace ignitor 5. Adjust ignitor wires as shown in Figure 28 on page 16. Replace ignitor assembly if repositioning does not correct the problem 6. Replace ignitor 7. Install new alkaline battery in remote control and battery pack. Verify batteries are installed correctly. (5.4 volts batteries required to operate valve system)
When "ON" button on remote control is pressed, there is spark at ignitor but no ignition	<ol style="list-style-type: none"> 1. Gas supply turned off or equipment shutoff valve closed 2. Air in gas lines when installed 3. Depleted gas supply (propane/LP only) 4. Control module not in REMOTE position 5. Gas control valve pressure setting is not correct 6. Inlet gas pressure is too low 7. Burner orifice(s) clogged 8. Wire disconnected from gas control 9. Ground wire issue 	<ol style="list-style-type: none"> 1. Turn on gas supply or open equipment shutoff valve 2. Repeat igniting operation until air is removed 3. Contact local propane/LP gas company 4. Set control module to REMOTE position 5. Contact qualified service person to check pressure 6. Contact local natural or propane/LP gas company 7. Clean burner (see <i>Cleaning and Maintenance</i>, page 18) or replace burner orifice(s) 8. See <i>Wiring Diagram</i>, page 20 9. Verify black ground wire from module is secured under screw adjacent to ignitor

TROUBLESHOOTING

Continued

OBSERVED PROBLEM	POSSIBLE CAUSE	REMEDY
Delayed ignition of burner	1. Manifold pressure is too low	1. Contact local natural or propane/LP gas company
	2. Burner orifice clogged	2. Clean burner (see <i>Cleaning and Maintenance</i> , page 18) or replace burner orifice(s)
Burner backfiring during combustion	1. Burner orifice is clogged or damaged	1. Clean burner (see <i>Cleaning and Maintenance</i> , page 18) or replace burner orifice
	2. Damaged burner	2. Replace damaged burner
Slight smoke or odor during initial operation	1. Residues from manufacturing processes	1. Problem will stop after a few hours of operation
Appliance produces a whistling noise when burners are lit	1. Air in gas line	1. Operate burners until air is removed from line. Have gas line checked by local natural or propane/LP gas company
	2. Air passageways on appliance blocked	2. Observe minimum installation clearances (see pages 5 through 8)
	3. Dirty or partially clogged burner orifice.	3. Clean burner (see <i>Cleaning and Maintenance</i> , page 18) or replace burner orifice(s)
White powder residue forming within burner box or on adjacent walls or furniture	1. When heated, vapors from furniture polish, wax, carpet cleaners, etc. may turn into white powder residue	1. Turn appliance off when using furniture polish, wax, carpet cleaners or similar products
Remote does not function	1. Battery is not installed. Battery power is low	1. Replace batteries in battery pack and in hand-held remote
Appliance produces a clicking/ticking noise just after burners are lit or shut off	1. Metal expanding while heating or contracting while cooling	1. This is normal with most appliances. If noise is excessive, contact qualified service person
	2. Ignitor Assembly is out of position	2. Check ignitor position and adjust if needed. See Figure 28 page 16.
	3. Wind is disturbing the burner flame and the ignitor assembly is relighting the burner	3. Should wind disturb the burner flame, the ignitor will automatically spark to relight the burner. This is normal when the appliance is installed outdoors in windy conditions.
	4. Wire connection loose or wire broken	4. Check wiring connections (see <i>wiring diagram</i> , page 20). Replace wire harness if necessary.

TROUBLESHOOTING

Continued



WARNING: If you smell gas

- **Shut off gas supply.**
- **Do not try to light any appliance.**
- **Do not touch any electrical switch; do not use any phone in your building.**
- **Immediately call your gas supplier from a neighbor's phone. Follow the gas supplier's instructions.**
- **If you cannot reach your gas supplier, call the fire department.**

IMPORTANT: Operating fireplace where impurities in air exist may create odors. Cleaning supplies, paint, paint remover, cigarette smoke, cements and glues, new carpet or textiles, etc., create fumes. These fumes may mix with combustion air and create odors. These odors will disappear over time.

OBSERVED PROBLEM	POSSIBLE CAUSE	REMEDY
Appliance produces unwanted odors	<ol style="list-style-type: none"> 1. Appliance burning vapors from paint, hair spray, glues, cleaners, chemicals, new carpet, etc. (See <i>IMPORTANT</i> statement above) 2. Low fuel supply (propane/LP only) 3. Gas leak. See Warning statement at top of page 	<ol style="list-style-type: none"> 1. Stop using odor causing products while appliance is running 2. Refill supply tank (propane/LP only) 3. Locate and correct all leaks (see <u>Checking Gas Connections</u>, page 10)
Appliance shuts off in use	<ol style="list-style-type: none"> 1. Low line pressure 	<ol style="list-style-type: none"> 1. Contact local natural or propane/LP gas company
Gas odor even when control knob is in OFF position	<ol style="list-style-type: none"> 1. Gas leak. See Warning statement at top of page 2. Control valve or gas control defective 	<ol style="list-style-type: none"> 1. Locate and correct all leaks (see <u>Checking Gas Connections</u>, page 10) 2. Replace control valve or gas control
Module makes one beep every one second	<ol style="list-style-type: none"> 1. The burner did not successfully ignite 	<ol style="list-style-type: none"> 1. Press OFF then ON buttons to re-attempt ignition. Refer to "When "on" button on remote control is pressed, there is spark at ignitor but no ignition" on page 21
Gas odor during combustion	<ol style="list-style-type: none"> 1. Gas leak. See Warning statement at top of page 	<ol style="list-style-type: none"> 1. Locate and correct all leaks (see <u>Checking Gas Connections</u>, page 10)

PARTS

MODELS (V)LVFO43NE & (V)LVFO43PE

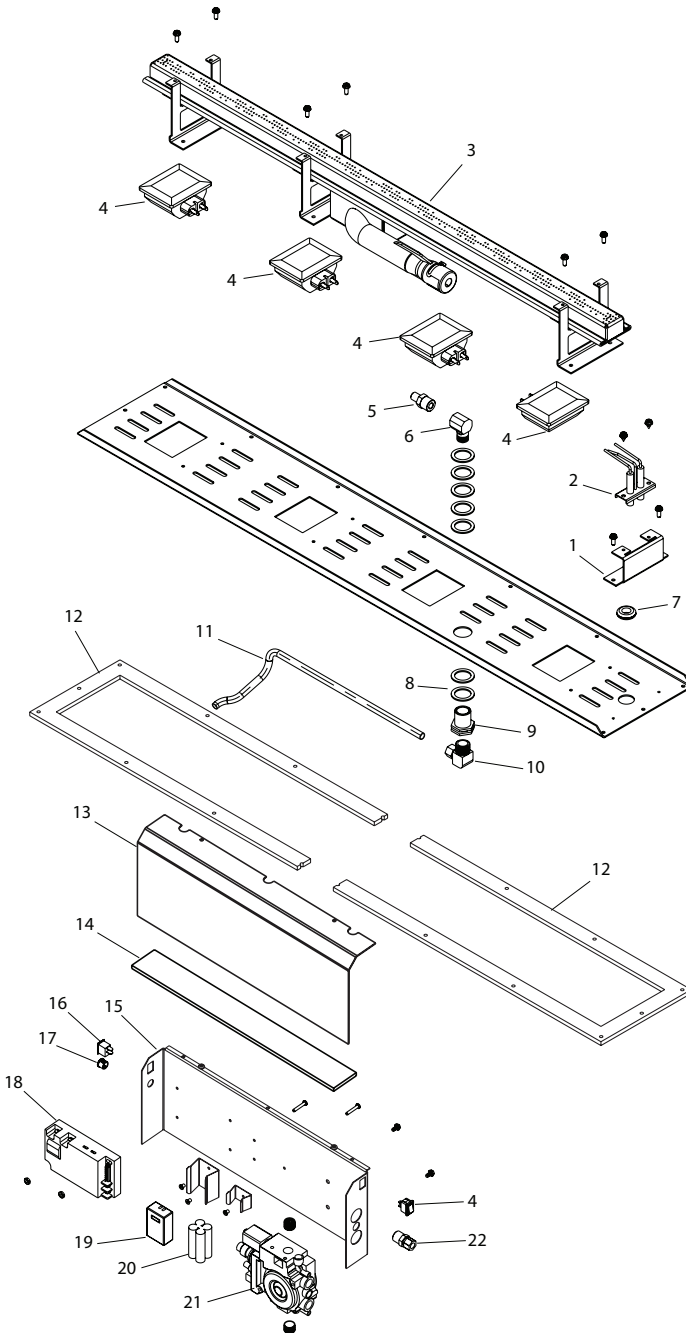

PARTS

This list contains replaceable parts used in your fireplace. When ordering parts, follow the instructions listed under Replacement Parts on page 27 of this manual.

KEY NO.	PART NO.	DESCRIPTION	(V)LVFO43NE	(V)LVFO43PE	QTY.
1	126396-01	Pilot Bracket	•	•	1
2	126398-01	Ignitor, Direct Spark	•	•	1
3	125752-02	Burner Assembly Stainless Steel	•	•	1
4	125961-02	Light Assembly w/ Wire Harness	•	•	1
	126130-02	Light Bulb, G9 120V/20W	•	•	2
5	24874	Orifice, #32	•		1
	23106	Orifice, #49		•	1
6	14296	Brass Elbow	•	•	1
7	114027-01	Grommet SC 1/2" ID 1 1/16" OD	•	•	1
8	116573-01	Flat Washer	•	•	7
9	11214	Bulkhead Fitting	•	•	1
10	14399	Brass Elbow	•	•	2
11	111817-01	Flextube,	•	•	1
12	125932-01	Burner Gasket	•	•	2
13	126050-02	Electronic Access Cover LVFO	•	•	1
14	126051-01	Insulation Heat Shield	•	•	1
15	125976-02	Bracket Valve Components	•	•	1
16	14607	Switch, Rocker ON/OFF Remote	•	•	1
17	11408	Bushing, Double Insulation	•	•	1
18	125643-01	Module, Control	•	•	1
19	125067-01	Module, Power	•	•	1
20	125068-01	Battery, Backup (W/Batteries)	•	•	1
21	125236-01	Valve Assy. W/Set Screw NG.	•	•	1
22	14396	Connector, 3/8 Tube X 3/8 MPT	•	•	1
PARTS AVAILABLE NOT SHOWN					
	121129-10	Control Module Wire Harness	•	•	1
	121129-11	Remote Receiver Wire Harness	•	•	1
	121129-09	Proflame Remote Control	•	•	1
	14253	30" Flex Line	•	•	1
	125999-04	Green Pebbles (6 lbs)	•	•	1

PARTS

MODELS (V)LVFO43NE & (V)LVFO43PE

This list contains replaceable parts used in your fireplace. When ordering parts, follow the instructions listed under Replacement Parts on page 27 of this manual.

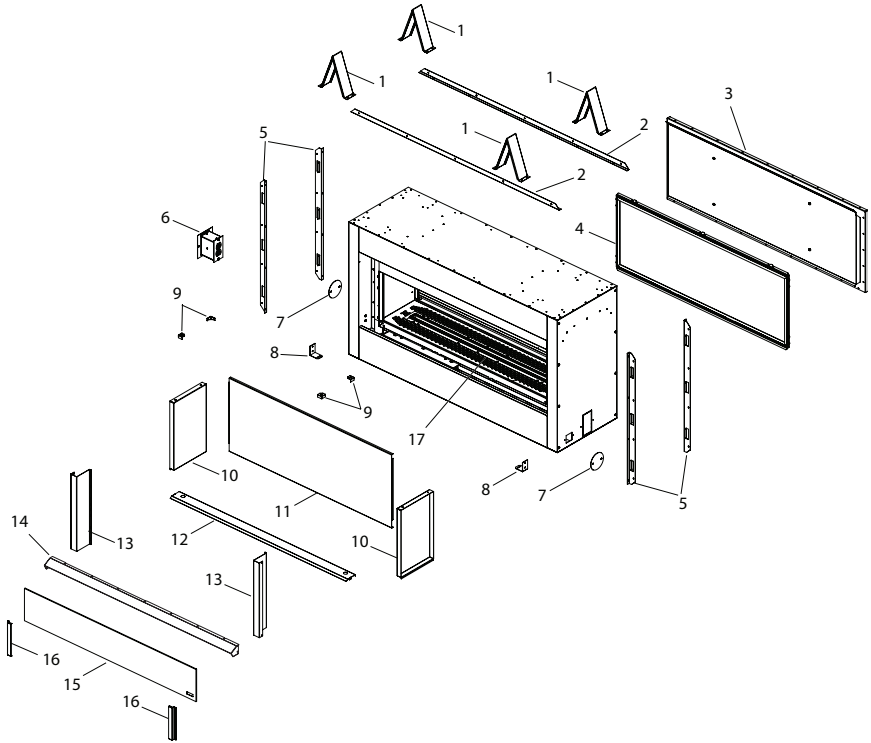

KEY

NO.	PART NO.	DESCRIPTION	(V)LVF43NE	(V)LVF43PE	QTY.
1	125847-01	Top Spacer	•	•	4
2	125757-02	Top Nailing Flange	•	•	2
3	125805-01	Rear Panel	•	•	1
4	125741-02	False Door Assembly	•	•	1
5	125757-01	Side Nailing Flange	•	•	4
6	110037-01	Electric Duct Assembly	•	•	1
7	21171	Cover Gas Conduit	•	•	2
8	125767-02	Access Cover Retaining Bracket	•	•	2
9	125763-02	Corner Bracket Stainless	•	•	4
10	125766-02	Side Walls	•	•	2
11	125761-02	Rear Wall LVFO	•	•	1
12	125768-02	Access Door Stainless	•	•	1
13	125766-02	Side Face Filler Stainless	•	•	2
14	125975-02	Fireplace Hood Stainless	•	•	1
15	126399-01	Glass, tempered	•	•	1
16	126397-01	Bracket, Glass Retainer	•	•	2
17	125753-02	Pebble Pan LVFO	•	•	1

SPECIFICATIONS

(V)LVFO43NE

- Rating (Variable): 25/39,000 Btu/Hr
- Gas Type: Natural Gas
- Ignition: Electronic
- Pressure Manifold Setting: 3.5" W.C.
- Inlet Gas Pressure (in. of water):
Maximum - 10.5" W.C.,
Minimum* - 5.5" W.C.

* For purposes of input adjustment

(V)LVFO42PE

- Rating (Variable): 29/37,000 Btu/Hr
- Gas Type: Propane/LP Gas
- Ignition: Electronic
- Pressure Manifold Setting: 10.5" W.C.
- Inlet Gas Pressure (in. of water):
Maximum - 14" W.C.,
Minimum* - 11" W.C.

* For purposes of input adjustment

REPLACEMENT PARTS

Note: Use only original replacement parts. This will protect your warranty coverage for parts replaced under warranty.

Contact authorized dealers of this product. If they can't supply original replacement part(s), call FMI PRODUCTS, LLC at 1-866-328-4537.

When calling, have ready:

- your name
- your address
- model and serial numbers of your heater
- how heater was malfunctioning
- purchase date

Usually, we will ask you to return the part to the factory.

SERVICE HINTS

When Gas Pressure Is Too Low

- pilot will not stay lit
- burner will have delayed ignition
- fireplace will not produce specified heat
- for propane/LP unit, propane/LP gas supply may be low

You may feel your gas pressure is too low. If so, contact your local gas supplier.

TECHNICAL SERVICE

You may have further questions about installation, operation, or troubleshooting. If so, contact FMI PRODUCTS, LLC at 1-866-328-4537. When calling please have your model and serial numbers of your heater ready.

You can also visit our web site at www.fmiproducts.com.

ACCESSORIES

NOTICE: All accessories may not be available for all fireplace models.

Purchase these accessories from your local dealer. If they can not supply these accessories call FMI PRODUCTS, LLC at 1-866-328-4537 for information. You can also write to the address listed on the back page of this manual.

SMOOTH GLASS PEBBLES (6 LBS)

- GP43SO - Speckled Orange
- GP43A - Amber
- GP43C - clear
- GP43B - Blue

OUTDOOR SEE-THRU DOOR KIT

LVOST

WARRANTY

KEEP THIS WARRANTY

Model (located on product or identification tag) _____

Serial No. (located on product or identification tag) _____

Date Purchased _____

Keep receipt for warranty verification.

FMI PRODUCTS, LLC LIMITED WARRANTIES

New Products

Standard Warranty: FMI PRODUCTS, LLC warrants this new product and any parts thereof to be free from defects in material and workmanship for a period of four (4) years from the date of first purchase from an authorized dealer provided the product has been installed, maintained and operated in accordance with FMI PRODUCTS, LLC's warnings and instructions.

For products purchased for commercial, industrial or rental usage, this warranty is limited to 90 days from the date of first purchase.

Factory Reconditioned Products

Limited Warranty: FMI PRODUCTS, LLC warrants factory reconditioned products and any parts thereof to be free from defects in material and workmanship for 30 days from the date of first purchase from an authorized dealer provided the product has been installed, maintained and operated in accordance with FMI PRODUCTS, LLC's warnings and instructions.

Terms Common to All Warranties

The following terms apply to all of the above warranties:

Always specify model number and serial number when contacting the manufacturer. To make a claim under this warranty the bill of sale or other proof of purchase must be presented.

This warranty is extended only to the original retail purchaser when purchased from an authorized dealer, and only when installed by a qualified installer in accordance with all local codes and instructions furnished with this product.

This warranty covers the cost of part(s) required to restore this product to proper operating condition and an allowance for labor when provided by a FMI PRODUCTS, LLC Authorized Service Center or a provider approved by FMI PRODUCTS, LLC. Warranty parts must be obtained through authorized dealers of this product and/or FMI PRODUCTS, LLC who will provide original factory replacement parts. Failure to use original factory replacement parts voids this warranty.

Travel, handling, transportation, diagnostic, material, labor and incidental costs associated with warranty repairs, unless expressly covered by this warranty, are not reimbursable under this warranty and are the responsibility of the owner.

Excluded from this warranty are products or parts that fail or become damaged due to misuse, accidents, improper installation, lack of proper maintenance, tampering, or alteration(s).

This is FMI PRODUCTS, LLC's exclusive warranty, and to the full extent allowed by law; this express warranty excludes any and all other warranties, express or implied, written or verbal and limits the duration of any and all implied warranties, including warranties of merchantability and fitness for a particular purpose to four (4) years on new products and 30 days on factory reconditioned products from the date of first purchase. FMI PRODUCTS, LLC makes no other warranties regarding this product.

FMI PRODUCTS, LLC's liability is limited to the purchase price of the product, and FMI PRODUCTS, LLC shall not be liable for any other damages whatsoever under any circumstances including indirect, incidental, or consequential damages.

Some states do not allow limitations on how long an implied warranty lasts or the exclusion or limitation of incidental or consequential damages, so the above limitation or exclusion may not apply to you.

This warranty gives you specific legal rights, and you may also have other rights which vary from state to state.

For information about this warranty contact:

FMI PRODUCTS, LLC
2701 S. Harbor Blvd.
Santa Ana, CA 92704
1-866-328-4537
www.fmiproducts.com

126417-01
Rev. A
08/12