

VANGUARD®

UNVENTED (VENT-FREE) GAS FIREPLACE INSERT OWNER'S OPERATION AND INSTALLATION MANUAL



We recommend that our products be installed and serviced by professionals who are certified in the U.S. by NFI (National Fireplace Institute).

www.nficertified.org

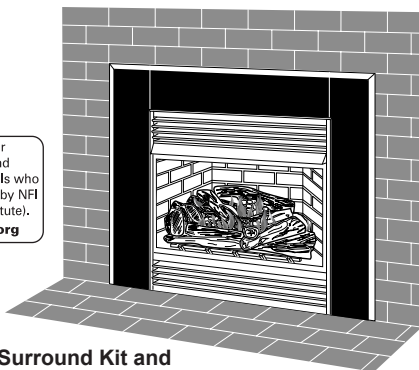

Shown with GS38 Surround Kit and
G8010 Brick Liner Accessories

VI33NRB AND VI33PRB REMOTE READY GAS FIREPLACE INSERT

⚠ WARNING: If the information in this manual is not followed exactly, a fire or explosion may result causing property damage, personal injury or loss of life.

- Do not store or use gasoline or other flammable vapors and liquids in the vicinity of this or any other appliance.
- **WHAT TO DO IF YOU SMELL GAS**
 - Do not try to light any appliance.
 - Do not touch any electrical switch; do not use any phone in your building.
 - Immediately call your gas supplier from a neighbor's phone. Follow the gas supplier's instructions.
 - If you cannot reach your gas supplier, call the fire department.
- Installation and service must be performed by a qualified installer, service agency or the gas supplier.

INSTALLER: Leave this manual with the appliance.
CONSUMER: Retain this manual for future reference.

For more information, visit www.desatech.com

TABLE OF CONTENTS

Safety	2	Cleaning and Maintenance.....	23
Local Codes.....	5	Wiring Diagrams	24
Unpacking.....	5	Troubleshooting	25
Product Identification	5	Specifications	29
Remote Control Accessories	6	Replacement Parts	29
Product Features	6	Technical Service.....	29
Air For Combustion and Ventilation	6	Service Hints	29
Installation	9	Parts	30
Operation.....	19	Accessories	34
Inspecting Burners.....	22	Warranty.....	Back Cover

SAFETY

⚠ WARNING: Improper installation, adjustment, alteration, service or maintenance can cause injury or property damage. Refer to this manual for correct installation and operational procedures. For assistance or additional information consult a qualified installer, service agency or the gas supplier.

This appliance may be installed in an aftermarket,* permanently located, manufactured (mobile) home, where not prohibited by local codes.

This appliance is only for use with the type of gas indicated on the rating plate. This appliance is not convertible for use with other gases.

* Aftermarket: Completion of sale, not for purpose of resale, from the manufacturer

⚠ WARNING: This is an unvented gas-fired heater. It uses air (oxygen) from the room in which it is installed. Provisions for adequate combustion and ventilation air must be provided. Refer to *Air for Combustion and Ventilation* section on page 6 of this manual.

⚠ WARNING: This product contains and/or generates chemicals known to the state of California to cause cancer or birth defects or other reproductive harm.

IMPORTANT: Read this owner's manual carefully and completely before trying to assemble, operate or service this fireplace. Improper use of this fireplace can cause serious injury or death from burns, fire, explosion, electrical shock and carbon monoxide poisoning.

SAFETY

Continued

⚠ DANGER: Carbon monoxide poisoning may lead to death!

Carbon Monoxide Poisoning: Early signs of carbon monoxide poisoning resemble the flu, with headaches, dizziness or nausea. If you have these signs, the fireplace may not be working properly. **Get fresh air at once!** Have fireplace serviced. Some people are more affected by carbon monoxide than others. These include pregnant women, people with heart or lung disease or anemia, those under the influence of alcohol and those at high altitudes.

Natural and Propane/LP Gas: Natural and Propane/LP gases are odorless. An odor-making agent is added to these gases. The odor helps you detect a gas leak. However, the odor added to the gas can fade. Gas may be present even though no odor exists.

Make certain you read and understand all warnings. Keep this manual for reference. It is your guide to safe and proper operation of this fireplace.

⚠ WARNING: Any change to this heater or its controls can be dangerous.

⚠ WARNING: Do not use a blower insert, heat exchanger insert or other accessory not approved for use with this fireplace.

⚠ WARNING: Do not allow fans to blow directly into the fireplace insert. Avoid any drafts that alter burner flame patterns. Ceiling fans can create drafts that alter burner flame patterns. Altered burner patterns can cause sooting.

⚠ WARNING: Any outside air ducts and/or ash dumps in the fireplace must be permanently closed before installing fireplace insert.

⚠ WARNING: Before installing in a solid fuel burning fireplace, the chimney flue and fireplace must be cleaned of soot, creosote, ashes and loose paint by a qualified chimney cleaner.

Due to high temperatures, the appliance should be located out of traffic and away from furniture and draperies.

Do not place clothing or other flammable material on or near the appliance. Never place any objects on the heater.

Fireplace insert front and screen become very hot when running fireplace insert. Keep children and adults away from hot surfaces to avoid burns or clothing ignition. Fireplace insert will remain hot for a time after shutdown. Allow surfaces to cool before touching.

Carefully supervise young children when they are in the room with fireplace. When using the hand-held remote accessory, keep selector switch in the OFF position to prevent children from turning on burners with remote.

You must operate this fireplace insert with the fireplace insert screen and hood in place. Make sure fireplace insert screen and hood are in place before running fireplace insert.

Keep the appliance area clear and free from combustible materials, gasoline and other flammable vapors and liquids.

SAFETY

Continued

1. This appliance is only for use with the type of gas indicated on rating plate. This appliance is not convertible for use with other gases.
2. Do not place propane/LP supply tank(s) inside any structure. Locate propane/LP supply tank(s) outdoors (propane/LP units only).
3. If you smell gas
 - shut off gas supply
 - do not try to light any appliance
 - do not touch any electrical switch; do not use any phone in your building
 - immediately call your gas supplier from a neighbor's phone. Follow gas supplier's instructions
 - if you cannot reach your gas supplier, call the fire department
4. This fireplace insert shall not be installed in a bedroom or bathroom.
5. Do not use this fireplace insert as a wood-burning fireplace. Use only logs provided with fireplace insert.
6. Do not add extra logs or ornaments such as pine cones, vermiculite or rock wool. Using these added items can cause soot-ing. Do not add lava rock around base. Rock and debris could fall into control area of fireplace insert.
7. This fireplace insert is designed to be smokeless. If logs ever appear to smoke, turn off fireplace insert and call a qualified service person.

Note: During initial operation, slight smoking could occur due to log curing and burning of manufacturing residues.
8. To prevent creation of soot, follow the instructions in Cleaning and Maintenance, page 23.
9. Before using furniture polish, wax, carpet cleaner or similar products, turn heater off. If heated, vapors from these products may create a white powder residue within burner box or on adjacent walls or furniture.
10. This fireplace insert needs fresh air ventilation to run properly. This fireplace insert has an Oxygen Depletion Sensing (ODS) safety shutoff system. The ODS shuts down the fireplace insert if not enough fresh air is available. See Air for Combustion and Ventilation, page 6. If fireplace insert keeps shutting off, see Troubleshooting, page 25.
11. Do not run fireplace insert
 - where flammable liquids or vapors are used or stored
 - under dusty conditions
12. Do not use this fireplace insert to cook food or burn paper or other objects.
13. Do not use fireplace insert if any part has been exposed to or under water. Immediately call a qualified service technician to inspect fireplace insert and to replace any part of the control system and any gas control which has been under water.
14. Do not operate fireplace insert if any log is broken. Do not operate fireplace insert if a log is chipped (dime-sized or larger).
15. Turn fireplace insert off and let cool before servicing. Only a qualified service person should service and repair fireplace insert.
16. Operating fireplace insert above elevations of 4,500 feet could cause pilot outage.
17. To prevent performance problems with propane/LP units, do not use propane/LP fuel tanks of less than 100 lb. capacity (propane/LP units only).
18. Provide adequate clearances around air openings.
19. Installer must mechanically attach marking supplied with vent-free fireplace insert to the inside of firebox of solid-fuel burning fireplace or listed firebox enclosure into which unvented fireplace insert is installed.
20. Trim panels and surrounds must not seal ventilation openings in fireplace.
21. Cutting any sheet metal parts of the solid-fuel burning fireplace or listed ventless firebox enclosure in which the vent-free fireplace insert is to be installed is prohibited.
22. If factory-built fireplace has no gas access hole(s) provided, an access hole of 1.5" (37.5 mm) diameter or less may be drilled through the lower sides or bottom of firebox in a proper manner. This access hole must be plugged with noncombustible insulation after the gas supply line has been installed.
23. Refractory, glass doors, screen rails, screen mesh and solid-fuel log grates (if applicable) can be removed from the fireplace before installing the unvented fireplace insert.
24. Smoke shelves, shields and baffles may be removed if attached by mechanical fasteners.

LOCAL CODES

Install and use fireplace insert with care. Follow all local codes. In the absence of local codes, use the latest edition of *The National Fuel Gas Code, ANSI Z223.1/NFPA 54**.

*Available from:

American National Standards Institute, Inc.
1430 Broadway
New York, NY 10018

National Fire Protection Association, Inc.
Batterymarch Park
Quincy, MA 02269

State of Massachusetts: The installation must be made by a licensed plumber or gas fitter in the Commonwealth of Massachusetts.

Sellers of unvented propane or natural gas-fired supplemental room heaters shall provide to each purchaser a copy of 527 CMR 30 upon sale of the unit.

Vent-free gas products are prohibited for bedroom and bathroom installation in the Commonwealth of Massachusetts.

UNPACKING

CAUTION: Do not remove the warning and instruction labels attached to the heater base assembly. These markings contain important warranty and safety information.

1. With utility knife, cut carton all the way around above staples on bottom tray. Lift carton off of heater. Remove packing.

Note: Hood is located in packing on right hand side of heater front. Lift heater off bottom tray.

2. Locate two screws above top corners of fireplace insert screen. Remove and discard these screws. Lift fireplace insert screen up and pull out to remove.
3. Remove protective packaging applied to logs, log base assembly and fireplace insert.
4. Remove fireplace insert hood from carton insert.
5. Check all items for any shipping damage. If damaged, promptly inform dealer where you bought fireplace insert.

PRODUCT IDENTIFICATION

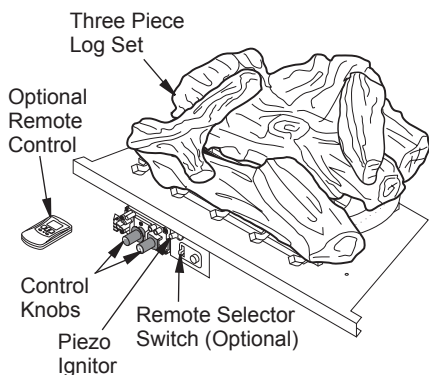

Figure 1 - Log Base Assembly

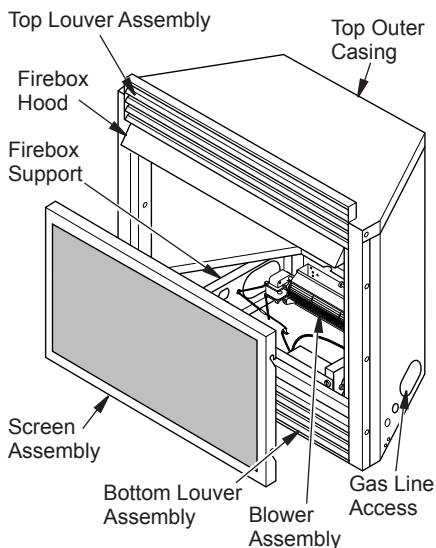

Figure 2 - Fireplace Insert

REMOTE CONTROL ACCESSORIES

There are four optional remote controls that can be purchased separately for this fireplace insert:

- wall switch
- wall thermostat

- hand-held ON/OFF remote
- hand-held thermostat remote

See Accessories, page 34.

PRODUCT FEATURES

OPERATION

This vent-free fireplace insert is clean burning. It requires no outside venting. There is no heat loss out a vent or up a chimney. Heat is generated by both realistic flames and glowing embers. When used without the blower, the fireplace insert requires no electricity making it ideal for emergency backup heat.

SAFETY DEVICE

This fireplace insert has a pilot with an Oxygen Depletion Sensing (ODS) safety shutoff system. The ODS/pilot is a required feature for vent-free room heaters. The ODS system shuts off the fireplace insert if there is not enough fresh air.

PIEZO IGNITION SYSTEM

This fireplace insert has a piezo ignitor. This system requires no matches, batteries or other sources to light fireplace insert.

BLOWER ASSEMBLY

This fireplace insert is equipped with a blower assembly. The blower operates thermostatically and has a variable control. The blower circulates heated air from the fireplace insert into the room. Use of blower is optional.

AIR FOR COMBUSTION AND VENTILATION

⚠ WARNING: This heater shall not be installed in a room or space unless the required volume of indoor combustion air is provided by the method described in the *National Fuel Gas Code, ANSI Z223.1/NFPA 54, the International Fuel Gas Code, or applicable local codes. Read the following instructions to insure proper fresh air for this and other fuel-burning appliances in your home.*

Today's homes are built more energy efficient than ever. New materials, increased insulation and new construction methods help reduce heat loss in homes. Home owners weather strip and caulk around windows and doors to keep the cold air out and the warm air in. During heating months, home owners want their homes as airtight as possible.

While it is good to make your home energy efficient, your home needs to breathe. Fresh air must enter your home. All fuel-burning appliances need fresh air for proper combustion and ventilation.

Exhaust fans, fireplaces, clothes dryers and fuel burning appliances draw air from the house to operate. You must provide adequate fresh air for these appliances. This will insure proper venting of vented fuel-burning appliances.

PROVIDING ADEQUATE VENTILATION

The following are excerpts from *National Fuel Gas Code ANSI Z223.1/NFPA 54, Air for Combustion and Ventilation*.

All spaces in homes fall into one of the three following ventilation classifications:

1. Unusually Tight Construction
2. Unconfined Space
3. Confined Space

The information on pages 6 through 8 will help you classify your space and provide adequate ventilation.

Unusually Tight Construction

The air that leaks around doors and windows may provide enough fresh air for combustion and ventilation. However, in buildings of unusually tight construction, you must provide additional fresh air.

Unusually tight construction is defined as construction where:

AIR FOR COMBUSTION AND VENTILATION

Continued

- walls and ceilings exposed to the outside atmosphere have a continuous water vapor retarder with a rating of one perm (6×10^{-11} kg per pa-sec-m²) or less with openings gasketed or sealed and
- weather stripping has been added on openable windows and doors and
- caulking or sealants are applied to areas such as joints around window and door frames, between sole plates and floors, between wall-ceiling joints, between wall panels, at penetrations for plumbing, electrical and gas lines and at other openings.

If your home meets all of the three criteria above, you must provide additional fresh air. See Ventilation Air From Outdoors, page 8.

If your home does not meet all of the three criteria above, proceed to Determining Fresh-Air Flow for Heater Location.

Confined and Unconfined Space

The National Fuel Gas Code ANSI Z223.1/NFPA 54 defines a confined space as a space whose volume is less than 50 cubic feet per 1,000 Btu per hour (4.8 m³ per kw) of the aggregate input rating of all appliances installed in that space and an unconfined space as a space whose volume is not less than 50 cubic feet per 1,000 Btu per hour (4.8 m³ per kw) of the aggregate input rating of all appliances installed in that space. Rooms communicating directly with the space in which the appliances are installed*, through openings not furnished with doors, are considered a part of the unconfined space.

* Adjoining rooms are communicating only if there are doorless passageways or ventilation grills between them.

DETERMINING FRESH-AIR FLOW FOR HEATER LOCATION

Determining if You Have a Confined or Unconfined Space

Use this work sheet to determine if you have a confined or unconfined space.

Space: Includes the room in which you will install fireplace plus any adjoining rooms with doorless passageways or ventilation grills between the rooms.

- Determine the volume of the space (length x width x height).
Length x Width x Height = _____ cu. ft. (volume of space)

Example: Space size 22 ft. (length) x 18 ft. (width) x 8 ft. (ceiling height) = 3168 cu. ft. (volume of space)

If additional ventilation to adjoining room is supplied with grills or openings, add the volume of these rooms to the total volume of the space.

- Multiply the space volume by 20 to determine the maximum Btu/Hr the space can support.

_____ (volume of space) x 20 = (Maximum Btu/Hr the space can support)

Example: 3168 cu. ft. (volume of space) x 20 = 63,360 (maximum Btu/Hr the space can support)

- Add the Btu/Hr of all fuel burning appliances in the space.

Vent-free fireplace	_____	Btu/Hr
Gas water heater*	_____	Btu/Hr
Gas furnace	_____	Btu/Hr
Vented gas heater	_____	Btu/Hr
Gas fireplace logs	_____	Btu/Hr
Other gas appliances* +	_____	Btu/Hr
Total	= _____	Btu/Hr

* Do not include direct-vent gas appliances. Direct-vent draws combustion air from the outdoors and vents to the outdoors.

Example:

	40,000	
Gas water heater	_____	Btu/Hr
Vent-free fireplace	+ _____	Btu/Hr
Total	= _____	Btu/Hr

- Compare the maximum Btu/Hr the space can support with the actual amount of Btu/Hr used.

_____ Btu/Hr (maximum the space can support)

_____ Btu/Hr (actual amount of Btu/Hr used)

Example: 63,360 Btu/Hr (maximum the space can support)

73,000 Btu/Hr (actual amount of Btu/Hr used)

The space in the above example is a confined space because the actual Btu/Hr used is more than the maximum Btu/Hr the space can support. You must provide additional fresh air. Your options are as follows:

- Rework worksheet, adding the space of an adjoining room. If the extra space provides an unconfined space, remove door to adjoining room or add ventilation grills between rooms. See Ventilation Air From Inside Building, page 8.
- Vent room directly to the outdoors. See Ventilation Air From Outdoors, page 8.
- Install a lower Btu/Hr fireplace, if lower Btu/Hr size makes room unconfined.

AIR FOR COMBUSTION AND VENTILATION

Continued

If the actual Btu/Hr used is less than the maximum Btu/Hr the space can support, the space is an unconfined space. You will need no additional fresh air ventilation.

⚠ WARNING: If the area in which the heater may be operated does not meet the required volume for indoor combustion air, combustion and ventilation air shall be provided by one of the methods described in the *National Fuel Gas Code, ANSI Z223.1/NFPA 54*, the *International Fuel Gas Code*, or applicable local codes.

VENTILATION AIR

Ventilation Air From Inside Building

This fresh air would come from an adjoining unconfined space. When ventilating to an adjoining unconfined space, you must provide two permanent openings: one within 12" of the ceiling and one within 12" of the floor on the wall connecting the two spaces (see options 1 and 2, Figure 3). You can also remove door into adjoining room (see option 3, Figure 3). Follow the *National Fuel Gas Code ANSI Z223.1/NFPA 54, Air for Combustion and Ventilation* for required size of ventilation grills or ducts.

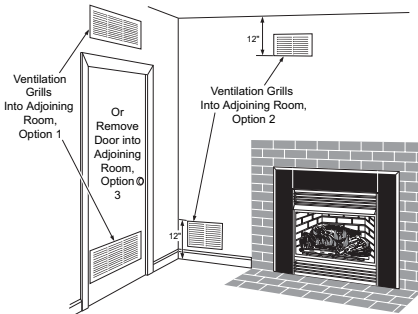

Figure 3 - Ventilation Air from Inside Building

Ventilation Air From Outdoors

Provide extra fresh air by using ventilation grills or ducts. You must provide two permanent openings: one within 12" of the ceiling and one within 12" of the floor. Connect these items directly to the outdoors or spaces open to the outdoors. These spaces include attics and crawl spaces. Follow the *National Fuel Gas Code ANSI Z223.1/NFPA 54, Air for Combustion and Ventilation* for required size of ventilation grills or ducts.

IMPORTANT: Do not provide openings for inlet or outlet air into attic if attic has a thermostat-controlled power vent. Heated air entering the attic will activate the power vent. Any outside air ducts and/or ash dumps in the fireplace shall be permanently closed at the time of appliance installation.

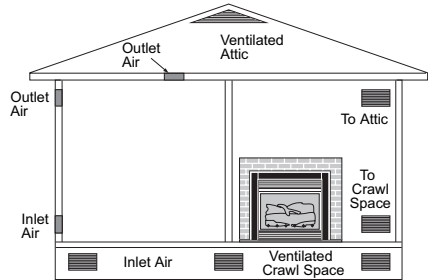

Figure 4 - Ventilation Air from Outdoors

INSTALLATION

NOTICE: This heater is intended for use as supplemental heat. Use this heater along with your primary heating system. Do not install this heater as your primary heat source. If you have a central heating system, you may run system's circulating blower while using heater. This will help circulate the heat throughout the house. In the event of a power outage, you can use this heater as your primary heat source.

⚠ WARNING: A qualified service person must install fireplace insert. Follow all local codes.

⚠ WARNING: Make sure the selector switch is in the OFF position before installing heater.

⚠ WARNING: Never install the fireplace insert

- in a bedroom or bathroom
- in a recreational vehicle
- where curtains, furniture, clothing or other flammable objects are less than 36" from front and 42" from top of fireplace insert. For side clearances see Figure 11, page 11
- in high traffic areas
- in windy or drafty areas

⚠ CAUTION: This fireplace insert creates warm air currents. These currents move heat to wall surfaces next to fireplace insert. Installing fireplace insert next to vinyl or cloth wall coverings or operating fireplace insert where impurities (such as, but not limited to, tobacco smoke, aromatic candles, cleaning fluids, oil or kerosene lamps, etc.) in the air exist, may discolor walls or cause odors.

⚠ WARNING: Before installing in a solid fuel burning fireplace, the chimney flue and firebox must be cleaned of soot, creosote, ashes and loose paint by a qualified chimney cleaner.

Note: Your Vanguard fireplace insert is designed to be used in zero clearance installations. Wall or framing material can be placed directly against any exterior surface on rear, sides or top of your fireplace insert, except where standoff spacers are integrally attached. If standoff spacers are attached to your insert, these spacers can be placed directly against wall or framing materials.

IMPORTANT: Vent-free heaters add moisture to the air. Although this is beneficial, installing fireplace in rooms without enough ventilation air may cause mildew to form from too much moisture. See [Air for Combustion and Ventilation](#), page 6.

IMPORTANT: Make sure the fireplace insert is level. If fireplace insert is not level, log set will not work properly.

CHECK GAS TYPE

Use the correct gas type (natural or propane/LP) for your unit. If your gas supply is not correct, do not install fireplace insert. Call dealer where you bought fireplace insert for proper type fireplace insert.

⚠ WARNING: This appliance is equipped for either natural gas or propane/LP gas but not both. Gas type is indicated on the rating plate. Field conversion is not permitted.

ELECTRICAL HOOKUP

(Blower Accessory)

This fireplace insert includes a blower assembly with an electrical cord. The electrical cord is five feet in length. You must locate fireplace insert within reach of a 120 volt grounded electrical outlet. If not, install and properly ground GA3555, three-prong 120 volt electrical outlet, in fireplace insert. Follow instructions included in kit (see [Accessories](#), page 34).

INSTALLATION

Continued

INSTALLING SURROUND KIT (GS38 OR GS43)

CAUTION: Close masonry fireplace damper securely before installing fireplace insert. If chimney does not have a damper, block or cap top of chimney. Failure to cap an open chimney could cause drafts that can affect the heater's performance and increase surface temperatures.

CAUTION: A GS38 or GS43 surround kit accessory must be installed on this fireplace insert before installing into your masonry fireplace or wall opening.

Note: Use the accessory which best covers the existing masonry fireplace opening or wall opening.

- Model GS38 Surround Kit (for use with fireplaces with an opening smaller than 30" H and 38" W).
 - Model GS43 Surround Kit (for use with fireplaces with an opening 30" to 36 3/4" H and 38 to 43" W).
1. Using a 5/16" nut driver, remove two shipping screws and screen (see Figure 5). Discard these screws. Remove 5/16" screen mounting shoulder screws (do not discard).
 2. Remove log packaging from firebox cavity.
 3. Align holes in left surround side panel with screen mounting screw holes. Replace 5/16" screen mounting shoulder screws removed in step 1 (see Figure 6). Do not tighten. Install Phillips screw in bottom (see Figure 6). Repeat for right side.
 4. Using Phillips screwdriver, remove 4 screws attaching top louver (see Figure 7).

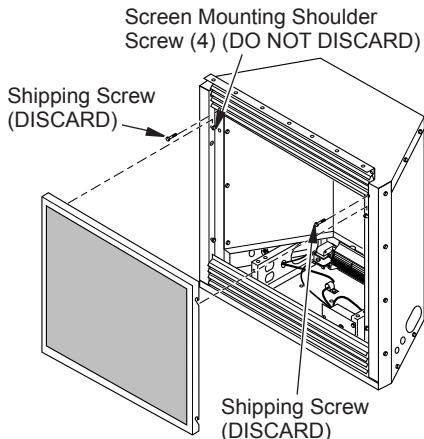

Figure 5 - Removing Screws and Screen

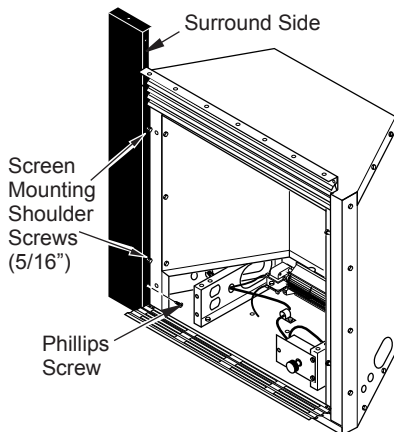

Figure 6 - Attaching Left Surround Side Panel

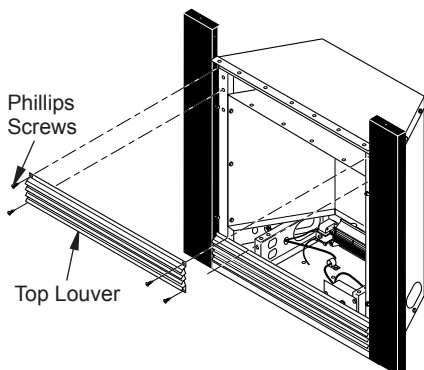

Figure 7 - Removing Louver

INSTALLATION

Continued

5. Place top surround panel at top of fireplace insert. Bottom edge of panel will slide under top edge of insert. Align top panel screw holes with those in insert. Install four #10 Phillips screws, do not tighten. See Figure 8.
6. Align screw holes in side panels with holes in top panel (see Figure 9). Insert and tighten #10 Phillips screws.
7. Reinstall louver removed in step 4, page 10.
8. Carefully inspect fireplace surround assembly. Make sure each part fits properly. Firmly tighten all screws installed during assembly.

CAUTION: Do not overtighten. Metal can bend, warp or break under excessive strain.

9. Install trim after final finishing and/or painting of wall.

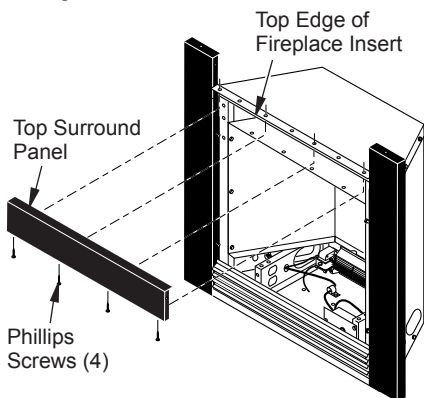

Figure 8 - Attaching Top Surround Panel

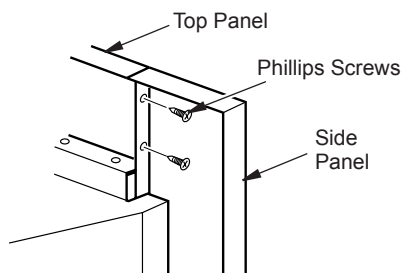

Figure 9 - Attaching Side Panels to Top Panel

INSTALLING HOOD

Install hood to top of firebox as shown in Figure 10. Use 5 Phillips screws (provided) to attach hood to fireplace insert and 2 Phillips screws (provided) to attach hood and surround sides to fireplace insert.

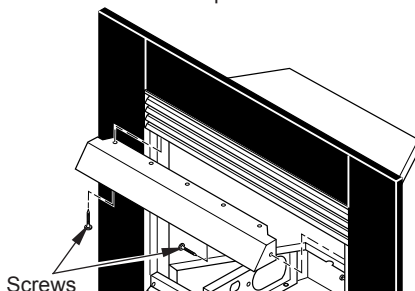

Figure 10 - Installing Hood to Firebox

INSTALLATION CLEARANCES

WARNING: Maintain the minimum clearances. If you can, provide greater clearances from floor, ceiling and adjoining wall.

Carefully follow instructions below. This will ensure safe installation.

Minimum Clearances For Side Combustible Material, Side Wall and Ceiling

- A. Clearances from side of fireplace cabinet to any combustible material and wall should follow diagram in Figure 12, page 12.

Example: The face of a mantel, bookshelf, etc. is made of combustible material and protrudes 3 1/2" from the wall. This combustible material must be 4" from side of fireplace opening (see Figure 11).

- B. Clearances from top of fireplace opening to ceiling should not be less than 42".

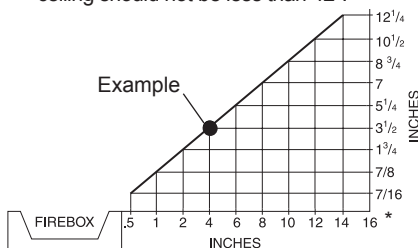

*Minimum 16" from Side Wall

Figure 11 - Minimum Clearance for Combustible to Wall

INSTALLATION

Continued

Mantel Clearances for Insert Installation

If there is a mantel above masonry fireplace, you must meet minimum clearance between mantel shelf and top of fireplace opening (see Figure 12).

NOTICE: Surface temperatures of adjacent walls and mantels become hot during operation. Walls and mantels above the firebox may become hot to the touch. If installed properly, these temperatures meet the requirements of the national product standard. Follow all minimum clearances shown in this manual.

NOTICE: If your installation does not meet the minimum clearances shown, you must do one of the following:

- raise the mantel to an acceptable height
- remove the mantel

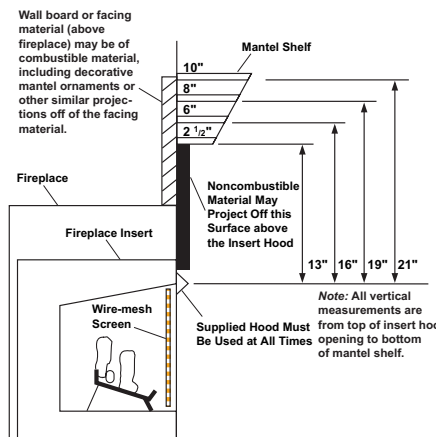

Figure 12 - Minimum Mantel Clearances for Fireplace Insert Installation

INSTALLING GAS PIPING TO FIREPLACE LOCATION

WARNING: A qualified service person must connect fireplace Insert to gas supply. Follow all local codes.

CAUTION: Never connect propane/LP heater directly to the propane/LP supply. This heater requires an external regulator (not supplied). Install the external regulator between the heater and propane/LP supply.

WARNING: Never connect natural gas fireplace insert to private (non-utility) gas wells. This gas is commonly known as wellhead gas.

Installation Items Needed

Before installing fireplace insert, make sure you have the items listed below.

- external regulator (supplied by installer)
- piping (check local codes)
- sealant (resistant to propane/LP gas)
- equipment shutoff valve *
- test gauge connection *
- sediment trap
- tee joint
- pipe wrench
- approved flexible gas line with gas connector (if allowed by local codes) (not provided)

* A CSA design-certified equipment shutoff valve with 1/8" NPT tap is an acceptable alternative to test gauge connection. Purchase the optional CSA design-certified equipment shutoff valve from your dealer.

INSTALLATION

Continued

For propane/LP units, installer must supply an external regulator. External regulator will reduce incoming gas pressure. You must reduce incoming gas pressure to between 11" and 14" of water. If you do not reduce incoming gas pressure, heater regulator damage could occur. Install external regulator with the vent pointing down as shown in Figure 13. Pointing vent down protects it from freezing rain or sleet.

CAUTION: Use only new, black iron or steel pipe. Internally-tinned copper tubing may be used in certain areas. Check your local codes. Use pipe of 1/2" diameter or greater to allow proper gas volume to fireplace insert. If pipe is too small, undue loss of volume will occur.

Installation must include an equipment shutoff valve and plugged 1/8" NPT tap. Locate NPT tap within reach for test gauge hook up. NPT tap must be upstream from fireplace insert (see Figure 14).

IMPORTANT: Install equipment shutoff valve in an accessible location. The equipment shutoff valve is for turning on or shutting off the gas to the appliance.

Check your building codes for any special requirements for locating equipment shutoff valve to fireplaces.

Apply pipe joint sealant lightly to male NPT threads. This will prevent excess sealant from going into pipe. Excess sealant in pipe could result in clogged fireplace valves.

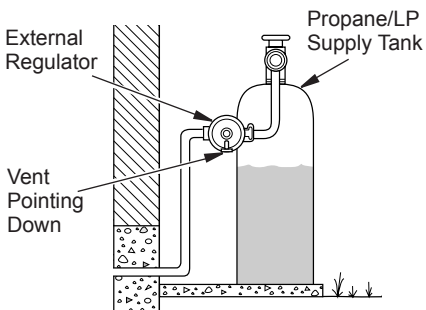

Figure 13 - External Regulator with Vent Pointing Down

WARNING: Use pipe joint sealant that is resistant to liquid petroleum (LP) gas.

We recommend that you install a sediment trap in supply line as shown in Figure 14. Locate sediment trap where it is within reach for cleaning. Install in piping system between fuel supply and heater. Locate sediment trap where trapped matter is not likely to freeze. A sediment trap traps moisture and contaminants. This keeps them from going into fireplace insert gas controls. If sediment trap is not installed or is installed wrong, fireplace may not run properly.

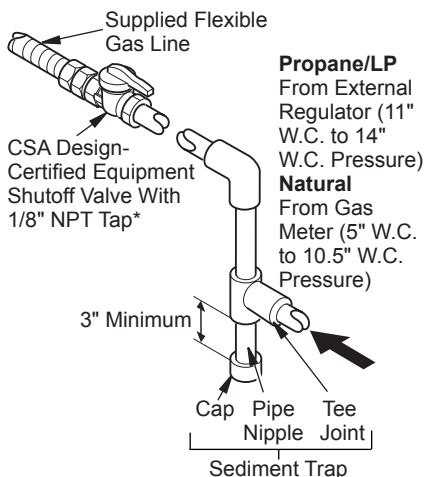

Figure 14 - Gas Connection

* Purchase the optional CSA design-certified equipment shutoff valve from your dealer.

CONNECTING FIREPLACE INSERT TO GAS SUPPLY

Installation Items Needed

- 5/16" hex socket wrench or nut-driver
 - Phillips screwdriver
 - sealant (resistant to propane/LP gas, not provided)
1. Remove fireplace insert screen. Lift fireplace insert screen up and pull out to remove.

INSTALLATION

Continued

- Remove screws that attach log base assembly to fireplace insert (see Figure 15). Carefully lift up log base assembly and remove from fireplace insert (see Figure 15).

Note: If adding the G8010 series brick liner accessory, install it now. Follow instructions in G8010 accessory kit.

CAUTION: Do not pick up log base assembly by burners. This could damage burners. Only handle base by grates.

- Route gas supply line through access opening of fireplace insert (see Figure 15).

NOTICE: Most building codes do not permit concealed gas connections. A flexible gas line is provided to allow accessibility from the fireplace (see Figure 16). The flexible gas supply line connection to the equipment shutoff valve should be accessible.

- Connect gas supply line to flexible gas line attached to gas regulator of fireplace insert (see Figure 16). Use sealant on all male pipe threads.
- Check all gas connections for leaks. See Checking Gas Connections.

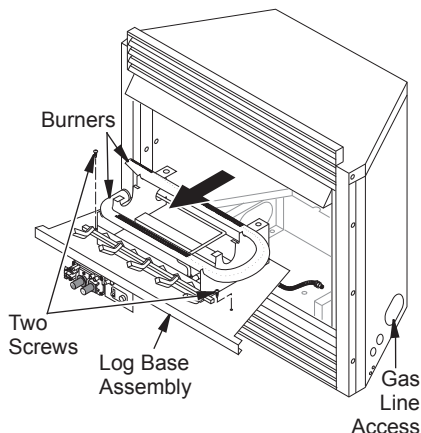

Figure 15 - Removing Log Base Assembly From Fireplace Insert

- Replace log base assembly back into fireplace insert. Feed flexible gas line into fireplace insert base area while replacing log base assembly. Make sure the entire flexible gas line is in fireplace insert base area. Reattach log base assembly to fireplace insert with screws removed in step 2.

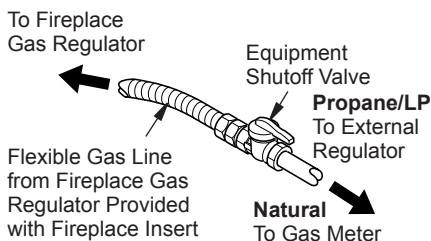

Figure 16 - Attaching Flexible Gas Lines Together

CHECKING GAS CONNECTIONS

WARNING: Test all gas piping and connections, internal and external to unit, for leaks after installing or servicing. Correct all leaks at once.

WARNING: Never use an open flame to check for a leak. Apply a noncorrosive leak detection fluid to all joints. Bubbles forming show a leak. Correct all leaks at once.

PRESSURE TESTING GAS SUPPLY PIPING SYSTEM

Test Pressures In Excess Of 1/2 PSIG (3.5 kPa)

- Disconnect appliance with its appliance main gas valve (control valve) and equipment shutoff valve from gas supply piping system. Pressures in excess of 1/2 psig will damage fireplace insert gas regulator.
- Cap off open end of gas pipe where equipment shutoff valve was connected.
- Pressurize supply piping system by either opening propane/LP supply tank for propane/LP gas or opening main gas valve located on or near gas meter or using compressed air.

INSTALLATION

Continued

4. Check all joints of gas supply piping system. Apply a noncorrosive leak detection fluid to all joints. Bubbles forming show a leak.
5. Correct all leaks at once.
6. Reconnect fireplace insert and equipment shutoff valve to gas supply. Check reconnected fittings for leaks.

Test Pressures Equal To or Less Than 1/2 PSIG (3.5 kPa)

1. Close equipment shutoff valve (see Figure 17).
2. Pressurize supply piping system by either opening propane/LP supply tank for propane/LP gas or opening main gas valve located on or near gas meter or using compressed air.
3. Check all joints from gas meter to equipment shutoff valve for natural gas (see Figure 18) or propane/LP supply to equipment shutoff valve for propane/LP (see Figure 19). Apply a noncorrosive leak detection fluid to all joints. Bubbles forming show a leak.
4. Correct all leaks at once.

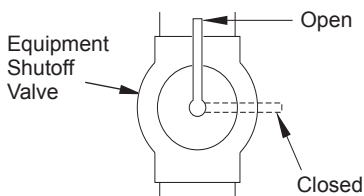

Figure 17 - Equipment Shutoff Valve

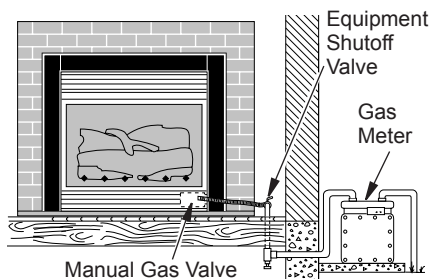

Figure 18 - Checking Gas Joints (Natural Gas)

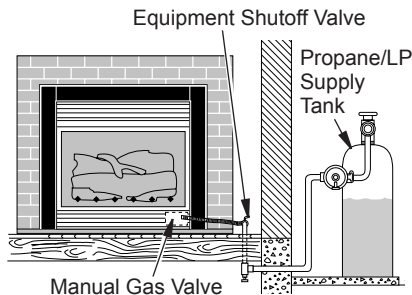

Figure 19 - Checking Gas Joints (Propane/LP Gas)

PRESSURE TESTING FIREPLACE INSERT GAS CONNECTIONS

1. Open equipment shutoff valve (see Figure 17).
2. Open main gas valve located on or near gas meter for natural gas or open propane/LP supply tank valve.
3. Make sure control knob of fireplace insert is in the OFF position.
4. Check all joints from gas meter to equipment shutoff valve for natural gas (see Figure 18) or propane/LP supply to equipment shutoff valve for propane/LP (see Figure 19). Apply a noncorrosive leak detection fluid to all joints. Bubbles forming show a leak.
5. Correct all leaks at once.
6. Light fireplace insert (see [Operation](#), page 19). Check all other internal joints for leaks.
7. Turn off fireplace insert (see [To Turn Off Gas to Appliance](#), page 20).

FIREPLACE INSERT INSTALLATION INTO MASONRY FIREPLACE

Installation of this fireplace insert involves installing fireplace insert into an existing masonry fireplace. If using a mantel above the fireplace, you must follow the clearances shown in Figure 12, page 12. Follow instructions below to install fireplace insert in this manner.

1. Use dimensions shown in Figure 20, page 16 for masonry fireplace opening.
2. Install and properly ground GA3555, three-prong 120 volt electrical outlet, in fireplace insert. Follow instructions included in kit (see [Accessories](#), page 34).

INSTALLATION

Continued

3. Install gas piping to fireplace location. This installation includes an approved flexible gas line (if allowed by local codes) after equipment shutoff valve. Flexible gas line must be the last item installed on gas piping. See *Installing Gas Piping to Fireplace Location*, page 12.
4. Carefully set fireplace insert in front of masonry fireplace with back of insert inside wall opening.
5. Attach flexible gas line to gas supply. See *Connecting Fireplace Insert to Gas Supply*, page 13.
6. Plug electrical cord into electrical outlet installed in step 2.
7. Carefully place fireplace insert into masonry fireplace.
8. Check all gas connections for leaks. See *Checking Gas Connections*, page 14.
9. Install trim after final finishing and/or painting of wall (see Figure 22).
4. Slide one end of adjusting plate/shim in slot of top surround trim (see Figure 21).
5. Slide other end of adjusting plate/shim in slot on mitered edge of side surround trim (see Figure 21).
6. While firmly holding edges of trim together, tighten both set screws on adjusting plate with slotted screwdriver.
7. Repeat steps 3 through 6 for other side.
8. Line up holes in surround trim with holes on side panels of fireplace surround assembly. Attach with screws provided (see Figure 22).
9. Move heater and surround assembly to fireplace opening. Make sure heater and surround assembly fit properly.

	Insert	Minimum Fireplace Opening
Height	25 ⁹ / ₁₆ "	26 ¹ / ₄ "
Front Width	34 ⁵ / ₁₆ "	35"
Depth	16 ¹¹ / ₁₆ "	17 ¹ / ₄ "

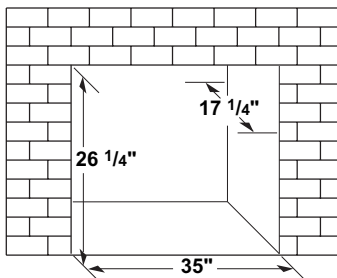

Figure 20 - Rough Opening for Installing in Masonry Fireplace

ASSEMBLING AND ATTACHING TRIM

1. Remove three pieces of surround trim from packaging.
2. Locate four #6 screws, two adjusting plates with set screws and two shims in the hardware packet.
3. Align shim under adjusting plate as shown in Figure 21.

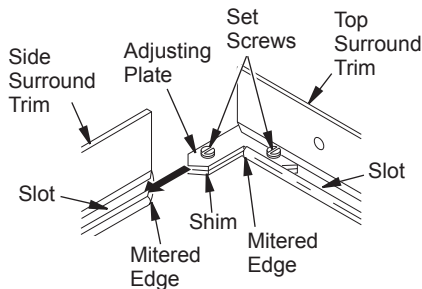

Figure 21 - Assembling Surround Trim

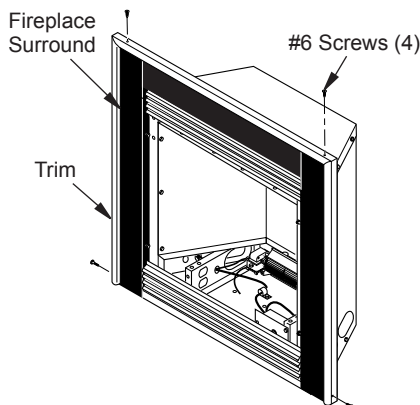

Figure 22 - Attaching Trim to Fireplace Surround

INSTALLATION

Continued

INSTALLING LOGS

CAUTION: Do not remove the warning and instruction labels attached to the heater base assembly. These markings contain important warranty and safety information.

WARNING: Failure to position the parts in accordance with these diagrams or failure to use only parts specifically approved with this heater may result in property damage or personal injury.

WARNING: After installation and periodically thereafter, check to ensure that no flame comes in contact with any log. With the heater set to HI, check to see if flames contact any log. If so, reposition logs according to the log installation instructions in this manual. Flames contacting logs will create soot.

It is very important to install logs exactly as instructed. Do not modify logs. Only use logs supplied with heater.

1. Place back log #1 on grate to fit as illustrated in Figure 23. Make sure middle section at bottom of log set is seated into "U"-shaped cutout in center of chassis (see Figure 23). **IMPORTANT:** Make sure log does not cover any burner ports (see Figure 24).
2. Place front log #2 against front grate prongs as shown in Figure 23.
3. Place crossover log #3 on top of front and back logs as shown in Figure 23.
4. Place lava rock around base of heater if desired.

WARNING: You must operate this fireplace insert with the fireplace insert screen in place. Make sure fireplace insert screen is in place before running fireplace insert.

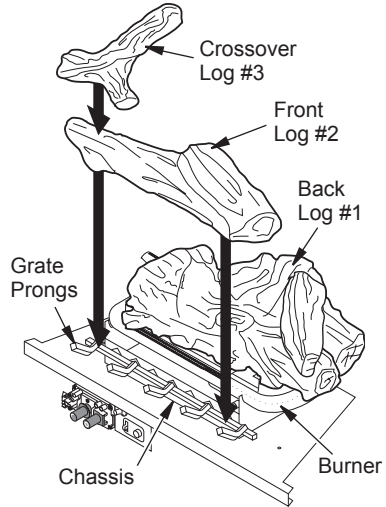

Figure 23 - Installing Log Set

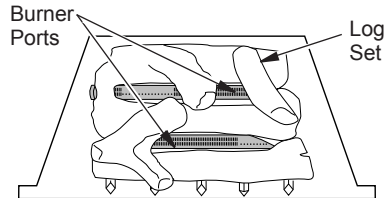

Figure 24 - Installing Log Set (Top View)

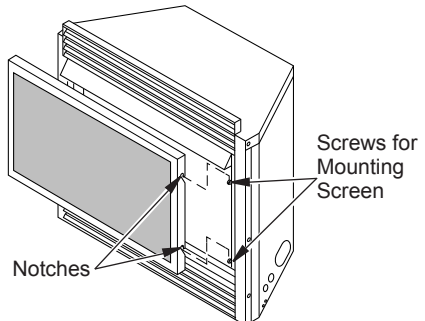

Figure 25 - Installing Screen

INSTALLATION

Continued

OPTIONAL WIRELESS HAND-HELD REMOTE CONTROL ACCESSORIES (HRC100 Series and HRC200 Series)

Installing Remote Receiver Unit

1. Disconnect switch wires from control valve.
2. Remove screws attaching switch plate.
3. Remove switch plate (see Figure 26). Discard after removing.
4. Install remote receiver unit onto gas log heater base using mounting clips.
5. Push clips firmly into place (see Figure 27).
6. Connect wires as shown in Figure 28.

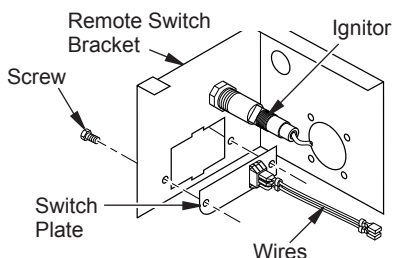

Figure 26 - Switch Plate and Wiring Harness

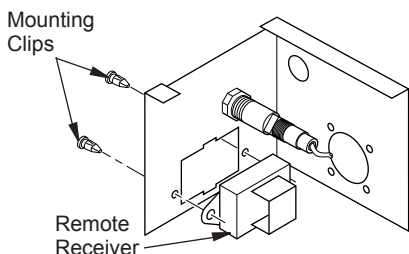

Figure 27 - Installing Remote Receiver

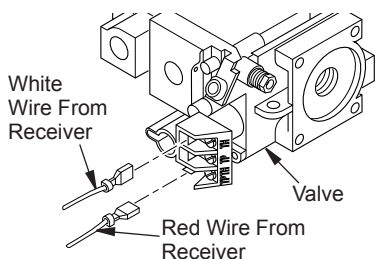

Figure 28 - Connecting Wires

INSTALLING 9-VOLT BATTERIES

Two 9-volt batteries (not included) are required to operate this heater with wireless hand-held remote control set. Install one battery in receiver and one in hand-held remote control unit.

Note: Only use alkaline batteries.

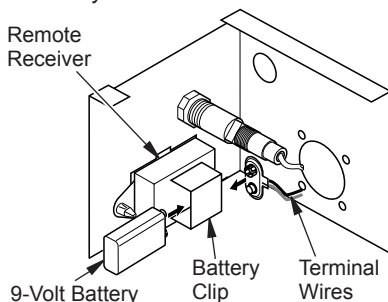

Figure 29 - Installing Battery in Remote Receiver

Installing 9-Volt Battery (Not Included) in Receiver

1. Locate back of receiver under front burner of heater.
2. Locate battery clip mounted on back of receiver.
3. Slide a 9-volt battery through the clip.
4. Attach terminal wires to battery.

Installing 9-Volt Battery (Not Included) in Hand-Held Remote Control Unit

1. Remove battery cover on back of remote control unit.
2. Attach terminal wires to battery. Place battery into battery housing.
3. Replace battery cover onto remote control unit.

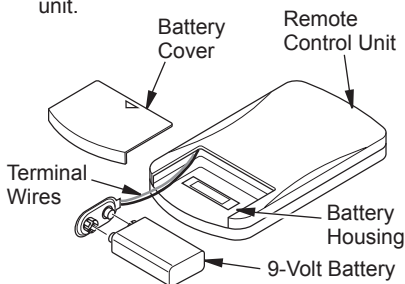

Figure 30 - Installing Battery in Hand-Held Remote Control Unit

OPERATION

FOR YOUR SAFETY READ BEFORE LIGHTING

⚠ WARNING: If you do not follow these instructions exactly, a fire or explosion may result causing property damage, personal injury or loss of life.

- A. This appliance has a pilot which must be lighted by hand. When lighting the pilot, follow these instructions exactly.
- B. **BEFORE LIGHTING** smell all around the appliance area for gas. Be sure to smell next to the floor because some gas is heavier than air and will settle on the floor.
- WHAT TO DO IF YOU SMELL GAS**
- Do not try to light any appliance.
 - Do not touch any electric switch; do not use any phone in your building.
 - Immediately call your gas supplier from a neighbor's phone. Follow the gas supplier's instructions.
 - If you cannot reach your gas supplier, call the fire department.
- C. Use only your hand to push in or turn the gas control knob. Never use tools. If the knob will not push in or turn by hand, don't try to repair it, call a qualified service technician or gas supplier. Force or attempted repair may result in a fire or explosion.
- D. Do not use this appliance if any part has been under water. Immediately call a qualified service technician to inspect the appliance and to replace any gas control which has been under water.



LIGHTING INSTRUCTIONS

⚠ WARNING: You must operate this heater with the fireplace insert screen in place. Make sure fireplace insert screen is installed before running fireplace insert.

NOTICE: During initial operation of new fireplace insert, burning logs will give off a paper-burning smell. Open damper or window to vent smell. This will only last a few hours.

1. STOP! Read the safety information column 1.
2. Make sure equipment shutoff valve is fully open.
3. Set switch to OFF position.

⚠ WARNING: Burners will come on automatically within one minute when the remote selector switch is in the ON position after the pilot is lit.

4. Press in and turn control knob clockwise  to the OFF position.
5. Wait five (5) minutes to clear out any gas. Then smell for gas, including near the floor. If you smell gas, STOP! Follow "B" in the safety information in column 1. If you don't smell gas, go to the next step.
6. Press in and turn control knob counter-clockwise  to the PILOT position. Press in control knob for five (5) seconds (see Figure 31).

Note: You may be running this heater for the first time after hooking up to gas supply. If so, the control knob may need to be pressed in for 30 seconds or more. This will allow air to bleed from the gas system.

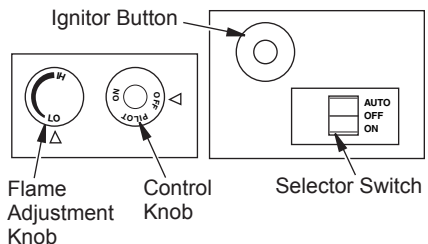

Figure 31 - Control Knob and Ignitor Button Location (Shown as Supplied, No Control Options)

OPERATION

Continued

7. With control knob pressed in, press and release ignitor button. This will light pilot. The pilot is attached to the front burner. If needed, keep pressing ignitor button until pilot lights.

Note: If pilot does not stay lit, contact a qualified service person or gas supplier for repairs. Until repairs are made, light pilot with match. To light pilot with match, see [Manual Lighting Procedure](#).

8. Keep control knob pressed in for 30 seconds after lighting pilot. After 30 seconds, release control knob.

• If control knob does not pop out when released, contact a qualified service person or gas supplier for repairs.

Note: If pilot goes out, repeat steps 4 through 8 starting on page 19.

9. Slightly push in and turn control knob counterclockwise to the ON position.
10. Wait one minute and switch selector switch to the ON position to light burners.
11. Set flame adjustment knob to any level between HI and LO.
12. To leave pilot lit and shut off burners only: turn control knob clockwise to the PILOT position, or use remote control manual OFF button, or set selector switch in the OFF position.

CAUTION: Do not try to adjust heating levels by using the equipment shutoff valve.

WARNING: Make sure the selector switch is in the OFF position when you are away from home for long periods of time. Heater will come on automatically with selector switch in the ON position.

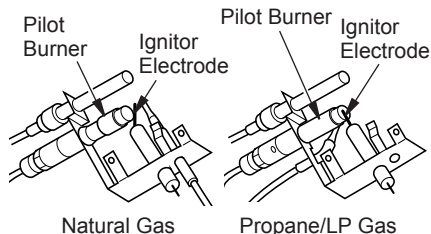

Figure 32 - Pilot

TO TURN OFF GAS TO APPLIANCE

1. Turn control knob clockwise to the OFF position.
- 2a. Set selector switch in the OFF position.
- 2b. **If Using Optional Hand-Held Remote:** Set remote selector switch in the OFF position to keep from draining battery.
3. Close equipment shutoff valve (see Figure 17, page 15).

MANUAL LIGHTING PROCEDURE

1. Follow steps 1 through 6 under [Lighting Instructions](#), page 19.
2. Press control knob and light pilot with match.
3. Keep control knob pressed in for 30 seconds after lighting pilot. After 30 seconds, release control knob. Now follow steps 9 through 11 under [Lighting Instructions](#), column 1.

OPTIONAL HAND-HELD REMOTE OPERATION

Note: All remote control accessories must be purchased separately (see [Accessories](#), page 34). Follow instructions included with the remote control.

NOTICE: You must light the pilot before using the hand-held remote control unit. See [Lighting Instructions](#) on page 19.

After lighting, let pilot flame burn for about one minute. Turn control knob to ON position. Adjust flame adjustment knob anywhere between HI and LO. Slide selector switch to REMOTE position (see Figure 33, page 21).

OPERATION

Continued

Note: The burner may light if hand-held remote was on when selector switch was last turned off. You can now turn burner on and off with hand-held remote control unit.

IMPORTANT: Do not leave selector switch in the REMOTE or ON position when pilot is not lit. This will drain battery.

Flame Adjustment Knob

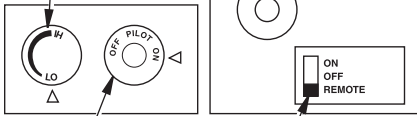

Control Knob in On Position

Remote Selector Switch in Remote Position (Optional Hand-Held Remote Control)

Figure 33 - Setting the Remote Selector Switch, Control Knob and Flame Adjustment Knob for Remote Operation

ON/OFF SERIES (MODEL HC100)

Hold the control button on hand-held remote until burner turns on. Hold the control button again until burner turns off (see Figure 34).

To Lock press both buttons on hand-held remote control until light stops flashing. Hand-held remote control is now locked. If fire is on it will be turned off automatically. In the locked state, light will not light up when any button is pressed.

To Unlock press both buttons together on hand-held remote control until light stops flashing. The hand-held remote is now unlocked.

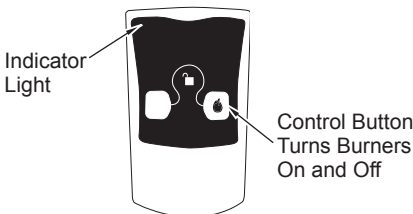

Figure 34 - On/Off Hand-Held Remote Control Unit (HRC100)

THERMOSTAT SERIES (MODEL HRC200)

The hand-held remote can be operated using either manual mode (MANU) or thermostatic mode (AUTO) (see Figure 35). To select Fahrenheit/Centigrade mode display, carefully press °C/°F mode button with the end of a paper clip or similar blunt object.

Manual Mode

1. Press POWER and LOCK buttons together to turn on hand-held remote control.
2. Press MANU button to turn on fireplace.
3. Press POWER and LOCK buttons together to turn off fireplace.

Auto (Thermostatic) Mode

1. Press POWER and LOCK buttons together to turn on hand-held remote control.
2. Press AUTO button to select this mode.
3. Set desired room temperature by pressing TEMP + or - buttons.
4. Press POWER and LOCK buttons together to turn off fireplace

Note: Do not leave hand-held remote in the AUTO mode close to fireplace. The radiant heat from fireplace will turn off fireplace. Ideally, place hand-held remote in the center of the room facing towards fireplace.

Note: Do not hold hand-held remote for a long time. Body temperature will affect its operation in AUTO mode.

Digital Display Shows Temperature and Settings

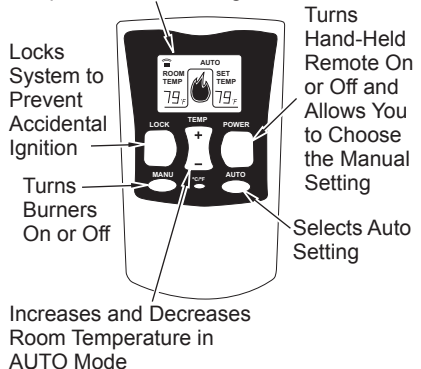

Figure 35 - Thermostat Hand-Held Remote Control Unit (HRC200)

OPERATION

Continued

Safety Features

When away from home for an extended period of time or as a child safety feature to prevent accidental ignition of the fireplace, receiver ON/OFF/REMOTE switch should be in the OFF position.

Auto Shutoff Feature

1. If the average room temperature reaches a range of 82° F (28° C) to 92° F (33° C), the hand-held remote control will perform a safety override and shut the fireplace off. This feature is not available in the MANU mode.
2. The receiver continuously receives signals from the hand-held remote to control the room temperature. If the hand-held remote is misplaced, obstructed, or for any reason cannot transmit to the receiver, the receiver will shut off the fireplace. This will occur in 8 or more minutes depending upon location of remote transmitter and strength of batteries.

Key Pad Lock Feature

This feature allows the user to lock/unlock keypad on hand-held remote in MANU or AUTO mode to prevent inadvertent operation (i.e. children operating hand-held remote

control, etc.). The keypad is locked in either on or off. Press POWER and LOCK buttons together to turn unit on or off.

OPTIONAL BLOWER OPERATION

Locate blower switch by opening lower louver on fireplace insert. Blower switch is located at lower left inside louver door.

This thermostat-controlled blower has three settings: ON, OFF and AUTO. In the ON position, blower will operate constantly. In the OFF position, blower will not operate. In the AUTO position, blower will start when thermostat senses a sufficient increase in firebox temperature.

Note: Your gas logs and thermostat blower will not turn on and off at the same time. The fireplace insert may run for several minutes before blower turns on. After heater modulates to pilot position, blower will continue to run. Blower will shut off after firebox temperature decreases.

Note: It is safe to operate fireplace insert with blower turned off. However, blower helps distribute heated air from fireplace insert.

INSPECTING BURNERS

Check pilot flame pattern and burner flame patterns often.

PILOT FLAME PATTERN

Figure 36 shows a correct pilot flame pattern. Figure 37 shows an incorrect pilot flame pattern. The incorrect pilot flame is not properly heating the thermocouple. When the thermocouple cools, the heater will shut down.

If pilot flame pattern is incorrect, as shown in Figure 37

- turn heater off (see [To Turn Off Gas to Appliance](#), page 20)
- see [Troubleshooting](#), page 25

Note: The pilot flame on natural gas units will have a slight curve, but flame should be blue and have no yellow or orange color.

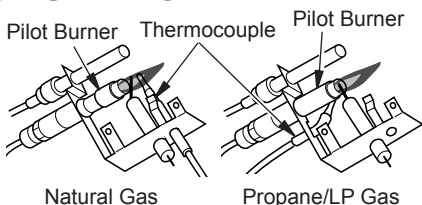

Figure 36 - Correct Pilot Flame Pattern

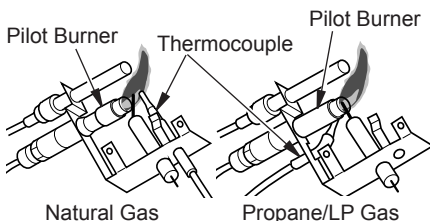

Figure 37 - Incorrect Pilot Flame Pattern

INSPECTING BURNERS

Continued

BURNER FLAME PATTERN

Figure 38 shows a correct burner flame pattern. Figure 39 shows an incorrect burner flame pattern. If burner flame pattern is incorrect,

- turn heater off (see *To Turn Off Gas to Appliance*, page 20)
- see *Troubleshooting*, page 25



Figure 38 - Correct Flame Pattern with Control Knob Set to High Flame.



Figure 39 - Incorrect Flame Pattern with Control Knob Set to High Flame

BURNER PRIMARY AIR HOLES

Air is drawn into the burner through holes in fitting at burner entrance. These holes may become blocked with dust or lint. Periodically inspect these holes for any blockage and clean if needed. Blocked air holes will create soot.

MAIN BURNER

Periodically inspect all burner flame holes with heater running. All slotted burner flame holes should be open with yellow flame present. All round burner flame holes should be open with a small blue flame present. Some burner flame holes may become blocked by debris or rust, with no flame present. If so, turn off heater and let cool. Remove blockage, blocked burner flame holes will create soot.

CLEANING AND MAINTENANCE

⚠ WARNING: Turn off heater and let cool before cleaning.

⚠ CAUTION: You must keep control areas, burner and circulating air passageways of heater clean. Inspect these areas of heater before each use. Have heater inspected yearly by a qualified service person. Heater may need more frequent cleaning due to excessive lint from carpeting, pet hair, bedding material, etc.

⚠ WARNING: Failure to keep the primary air opening(s) of the burner(s) clean may result in sooting and property damage.

BURNER INJECTOR HOLDER AND PILOT AIR INLET HOLE

The primary air inlet holes allow the proper amount of air to mix with the gas. This provides a clean burning flame. Keep these holes clear of dust, dirt, lint and pet hair. Clean these air inlet holes prior to each heating season. Blocked air holes will create soot. We recommend that you clean the unit every three months during operation and have heater inspected yearly by a qualified service person.

We also recommend that you keep the burner tube and pilot assembly clean and free of dust and dirt. To clean these parts we recommend using compressed air no greater than 30 PSI. Your local computer store, hardware store or home center may carry compressed air in a can. If using compressed air in a can, please follow directions on can. If you don't follow directions on can, you could damage pilot assembly.

CLEANING AND MAINTENANCE

Continued

1. Shut off unit, including pilot. Allow unit to cool for at least thirty minutes.
2. Inspect burner, pilot and primary air inlet holes on injector holder for dust and dirt (see Figure 40).
3. Blow air through ports/slots and holes in burner (see Figure 41).
4. Check injector holder located at the end of burner tube again. Remove any large particles of dust, dirt, lint or pet hair with a soft cloth or vacuum cleaner nozzle.
5. Blow air into primary air holes on injector holder.
6. In case any large clumps of dust have now been pushed into burner repeat steps 3 and 4.

Clean pilot assembly also. A yellow tip on pilot flame indicates dust and dirt in pilot assembly. There is a small pilot air inlet hole about 2" from where pilot flame comes out of pilot as-

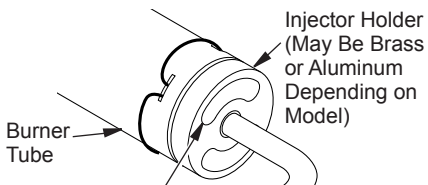

sembly (see Figure 41). With unit off, lightly blow air through air inlet hole. You may blow through a drinking straw if compressed air is not available.

Figure 40 - Injector Holder On Outlet Burner Tube

sembly (see Figure 41). With unit off, lightly blow air through air inlet hole. You may blow through a drinking straw if compressed air is not available.

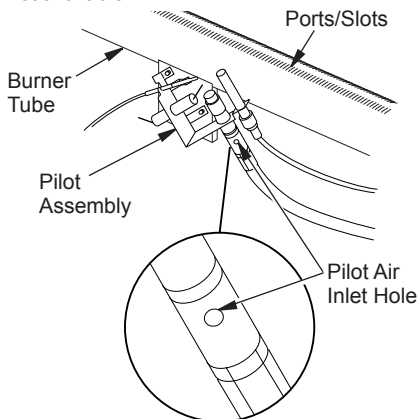

Figure 41 - Pilot Inlet Air Hole

LOGS

- If you remove logs for cleaning, refer to *Installing Logs*, page 17, to properly replace logs.
- Replace log(s) if broken or chipped (dime-sized or larger).

BURNER PRIMARY AIR HOLES

Air is drawn into burner through holes in fitting at burner entrance. These holes may become blocked with dust or lint. Periodically inspect these holes for any blockage and clean if needed. Blocked air holes will create soot.

WIRING DIAGRAMS

Note: For proper operation of optional accessories, the wires from the switch to the control must be connected exactly as shown in Figures 42 and 43.

CAUTION: Label all wires prior to disconnection when servicing controls. Wiring errors can cause improper and dangerous operation. Verify proper operation after servicing.

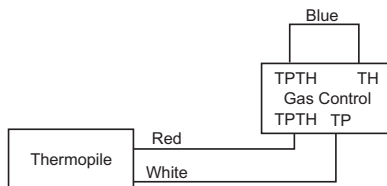

Figure 42 - Switch Wiring Diagram

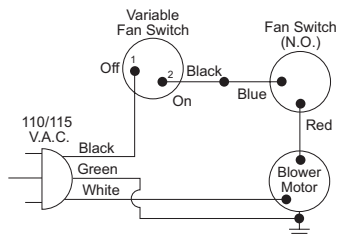

Figure 43 - Blower Wiring Diagram

TROUBLESHOOTING

⚠ WARNING: Turn off heater and let cool before servicing. Only a qualified service person should service and repair heater.

⚠ CAUTION: Never use a wire, needle or similar object to clean ODS/pilot. This can damage ODS/pilot unit.

Note: All troubleshooting items are listed in order of operation.

OBSERVED PROBLEM	POSSIBLE CAUSE	REMEDY
When ignitor button is pressed, there is no spark at ODS/pilot	<ol style="list-style-type: none"> 1. Ignitor electrode not connected to ignitor cable 2. Ignitor cable pinched or wet 3. Piezo ignitor nut is loose 4. Broken ignitor cable 5. Bad piezo ignitor 6. Ignitor electrode broken 7. Ignitor electrode positioned wrong 	<ol style="list-style-type: none"> 1. Reconnect ignitor cable 2. Free ignitor cable if pinched by any metal or tubing. Keep ignitor cable dry 3. Tighten nut holding piezo ignitor to base panel of log set. Nut is located behind base panel 4. Replace ignitor cable 5. Replace piezo ignitor 6. Replace pilot assembly 7. Replace pilot assembly
When ignitor button is pressed, there is spark at ODS/pilot but no ignition	<ol style="list-style-type: none"> 1. Gas supply turned off or equipment shutoff valve closed 2. Control knob not in PILOT position 3. Control knob not pressed in while in PILOT position 4. Air in gas lines when installed 5. Depleted gas supply (propane/LP only) 6. ODS/pilot is clogged 7. Gas regulator setting is not correct 	<ol style="list-style-type: none"> 1. Turn on gas supply or open equipment shutoff valve 2. Turn control knob to PILOT position 3. Press in control knob while in PILOT position 4. Continue holding down control knob. Repeat igniting operation until air is removed 5. Contact local propane/LP gas company 6. Clean ODS/pilot (see <u>Cleaning and Maintenance</u>, page 23) or replace ODS/pilot assembly 7. Replace gas control

TROUBLESHOOTING

Continued

OBSERVED PROBLEM	POSSIBLE CAUSE	REMEDY
<p>ODS/pilot lights but flame goes out when control knob is released</p>	<ol style="list-style-type: none"> 1. Control knob not fully pressed in 2. Control knob not pressed in long enough 3. Equipment shutoff valve not fully open 4. Pilot flame not touching thermocouple, which allows thermocouple to cool, causing pilot flame to go out. This problem could be caused by one or both of the following: A) Low gas pressure B) Dirty or partially clogged ODS/pilot 5. Thermocouple connection loose at control valve 6. Thermocouple damaged 7. Control valve damaged 	<ol style="list-style-type: none"> 1. Press in control knob fully 2. After ODS/pilot lights, keep control knob pressed in 30 seconds 3. Fully open equipment shut-off valve 4. A) Contact local natural or propane/LP gas company B) Clean ODS/pilot (see <i>Cleaning and Maintenance</i>, page 23) or replace ODS/pilot assembly 5. Hand tighten until snug, then tighten 1/4 turn more 6. Replace pilot assembly 7. Replace control valve
<p>Burner does not light after ODS/pilot is lit</p>	<ol style="list-style-type: none"> 1. Burner orifice clogged 2. Inlet gas pressure is too low 3. Thermopile leads disconnected or improperly connected 4. Burners will not come on in remote position 	<ol style="list-style-type: none"> 1. Clean burner (see <i>Cleaning and Maintenance</i>, page 23) or replace burner orifice 2. Contact local natural gas company 3. Reconnect leads (see <i>Wiring Diagrams</i>, page 24) 4. Replace battery in transmitter and receiver
<p>Delayed ignition burner</p>	<ol style="list-style-type: none"> 1. Manifold pressure is too low 2. Burner orifice clogged 	<ol style="list-style-type: none"> 1. Contact local natural or propane/LP gas company 2. Clean burner (see <i>Cleaning and Maintenance</i>, page 23) or replace burner orifice
<p>Burner backfiring during combustion</p>	<ol style="list-style-type: none"> 1. Burner orifice is clogged or damaged 2. Damaged burner 3. Gas regulator defective 	<ol style="list-style-type: none"> 1. Clean burner (see <i>Cleaning and Maintenance</i>, page 23) or replace burner orifice 2. Replace damaged burner 3. Replace gas control

TROUBLESHOOTING

Continued

OBSERVED PROBLEM	POSSIBLE CAUSE	REMEDY
Slight smoke or odor during initial operation	<ol style="list-style-type: none">1. Not enough air2. Gas regulator defective3. Residues from manufacturing processes and logs curing	<ol style="list-style-type: none">1. Check burner for dirt and debris. If found, clean burner (see <i>Cleaning and Maintenance</i>, page 23)2. Replace gas control3. Problem will stop after a few hours of operation
Moisture/condensation noticed on windows	<ol style="list-style-type: none">1. Not enough combustion/ventilation air	<ol style="list-style-type: none">1. Refer to <i>Air for Combustion and Ventilation</i> requirements (page 6)
Heater produces a whistling noise when burner is lit	<ol style="list-style-type: none">1. Turning control knob to HI position when burner is cold2. Air in gas line3. Air passageways on heater blocked4. Dirty or partially clogged burner orifice	<ol style="list-style-type: none">1. Turn control knob to LO position and let warm up for a minute2. Operate burner until air is removed from line. Have gas line checked by local natural or propane/LP gas company3. Observe minimum installation clearances (see page 11)4. Clean burner (see <i>Cleaning and Maintenance</i>, page 23) or replace burner orifice
White powder residue forming within burner box or on adjacent walls or furniture	<ol style="list-style-type: none">1. When heated, vapors from furniture polish, wax, carpet cleaners, etc. may turn into white powder residue	<ol style="list-style-type: none">1. Turn heater off when using furniture polish, wax, cleaners or similar products
Remote does not function	<ol style="list-style-type: none">1. Battery is not installed. Battery power is low	<ol style="list-style-type: none">1. Replace 9-volt batteries in receiver and hand-held remote control
Fireplace insert produces a clicking/ticking noise just after burners are lit or shut off	<ol style="list-style-type: none">1. Metal expanding while heating or contracting while cooling	<ol style="list-style-type: none">1. This is normal with most fireplaces. If noise is excessive, contact qualified service person

TROUBLESHOOTING

Continued



WARNING: If you smell gas

- **Shut off gas supply.**
- **Do not try to light any appliance.**
- **Do not touch any electrical switch; do not use any phone in your building.**
- **Immediately call your gas supplier from a neighbor's phone. Follow the gas supplier's instructions.**
- **If you cannot reach your gas supplier, call the fire department.**

IMPORTANT: Operating fireplace insert where impurities in air exist may create odors. Cleaning supplies, paint, paint remover, cigarette smoke, cements and glues, new carpet or textiles, etc., create fumes. These fumes may mix with combustion air and create odors. These odors will disappear over time.

OBSERVED PROBLEM	POSSIBLE CAUSE	REMEDY
Fireplace insert produces unwanted odors	<ol style="list-style-type: none"> 1. Fireplace insert burning vapors from paint, hair spray, glues, cleaners, chemicals, new carpet, etc. (see <i>IMPORTANT</i> statement above) 2. Low fuel supply (propane/LP only) 3. Gas leak. See Warning statement above 	<ol style="list-style-type: none"> 1. Open window and ventilate room. Stop using odor causing products while fireplace insert is running 2. Refill supply tank (propane/LP only) 3. Locate and correct all leaks (see <u><i>Checking Gas Connections</i></u>, page 14)
Fireplace insert shuts off in use (ODS operates)	<ol style="list-style-type: none"> 1. Not enough fresh air is available 2. Low line pressure 3. ODS/pilot is partially clogged 	<ol style="list-style-type: none"> 1. Open window and/or door for ventilation 2. Contact local natural gas company 3. Clean ODS/pilot (see <u><i>Cleaning and Maintenance</i></u>, page 23)
Gas odor even when control knob is in OFF position	<ol style="list-style-type: none"> 1. Gas leak. See Warning statement above 2. Control valve defective 	<ol style="list-style-type: none"> 1. Locate and correct all leaks (see <u><i>Checking Gas Connections</i></u>, page 14) 2. Replace control valve
Gas odor during combustion	<ol style="list-style-type: none"> 1. Foreign matter between control valve and burner 2. Gas leak. See Warning statement above 	<ol style="list-style-type: none"> 1. Take apart gas tubing and remove foreign matter 2. Locate and correct all leaks (see <u><i>Checking Gas Connections</i></u>, page 14)
Dark residue on logs or inside of fireplace insert. Note: After removing all causes of residue deposits, completely clean fireplace and appliance of all residue before reusing appliance	<ol style="list-style-type: none"> 1. Improper log placement 2. Drafts or other air currents affecting flame pattern 3. Air holes at burner inlet blocked 4. Burner flame holes blocked 	<ol style="list-style-type: none"> 1. Properly locate logs (see <u><i>Installing Logs</i></u>, page 17) 2. Eliminate source of drafts around heater 3. Clean out air holes at burner inlet. Periodically repeat as needed 4. Remove blockage

SPECIFICATIONS

VI33NRB

- Rating: 22,000/33,000 Btu/Hr
- Gas Type: Natural Gas
- Ignition: Piezo
- Pressure Manifold: 3.5" w.c.
- Inlet Gas Pressure (inches of water):
Max. - 10.5" w.c., Minimum* - 5" w.c.

* For input adjustment

VI33PRB

- Rating: 22,000/33,000 Btu/Hr
- Gas Type: Propane/LP Gas
- Ignition: Piezo
- Pressure Manifold: 8.0" w.c.
- Inlet Gas Pressure (inches of water):
Max. - 14" w.c., Minimum* - 11" w.c.

* For input adjustment

REPLACEMENT PARTS

Note: Use only original replacement parts. This will protect your warranty coverage for parts replaced under warranty.

PARTS UNDER WARRANTY

Contact authorized dealers of this product. If they can't supply original replacement part(s), call DESA Heating, LLC at 1-866-672-6040. When calling DESA Heating, LLC, have ready:

- your name
- your address
- model and serial numbers of your heater
- how heater was malfunctioning
- purchase date

TECHNICAL SERVICE

You may have further questions about installation, operation, or troubleshooting. If so, contact DESA Heating, LLC at 1-866-672-6040. When calling please have your model and serial numbers of your heater ready.

You can also visit DESA Heating, LLC's web site at www.desatech.com.

Usually, we will ask you to return the part to the factory.

PARTS NOT UNDER WARRANTY

Contact authorized dealers of this product. If they can't supply original replacement part(s), call DESA Heating, LLC at 1-866-672-6040 for referral information. A list of authorized dealers can be found by visiting www.desatech.com. When calling DESA Heating, LLC, have ready:

- model and serial numbers of your heater
- the replacement part number

SERVICE HINTS

When Gas Pressure Is Too Low

- pilot will not stay lit
- burners will have delayed ignition
- heater will not produce specified heat
- propane/LP gas supply may be low

You may feel your gas pressure is low. If so, contact your local natural or propane/LP gas supplier.

PARTS

MODELS VI33NRB AND VI33PRB

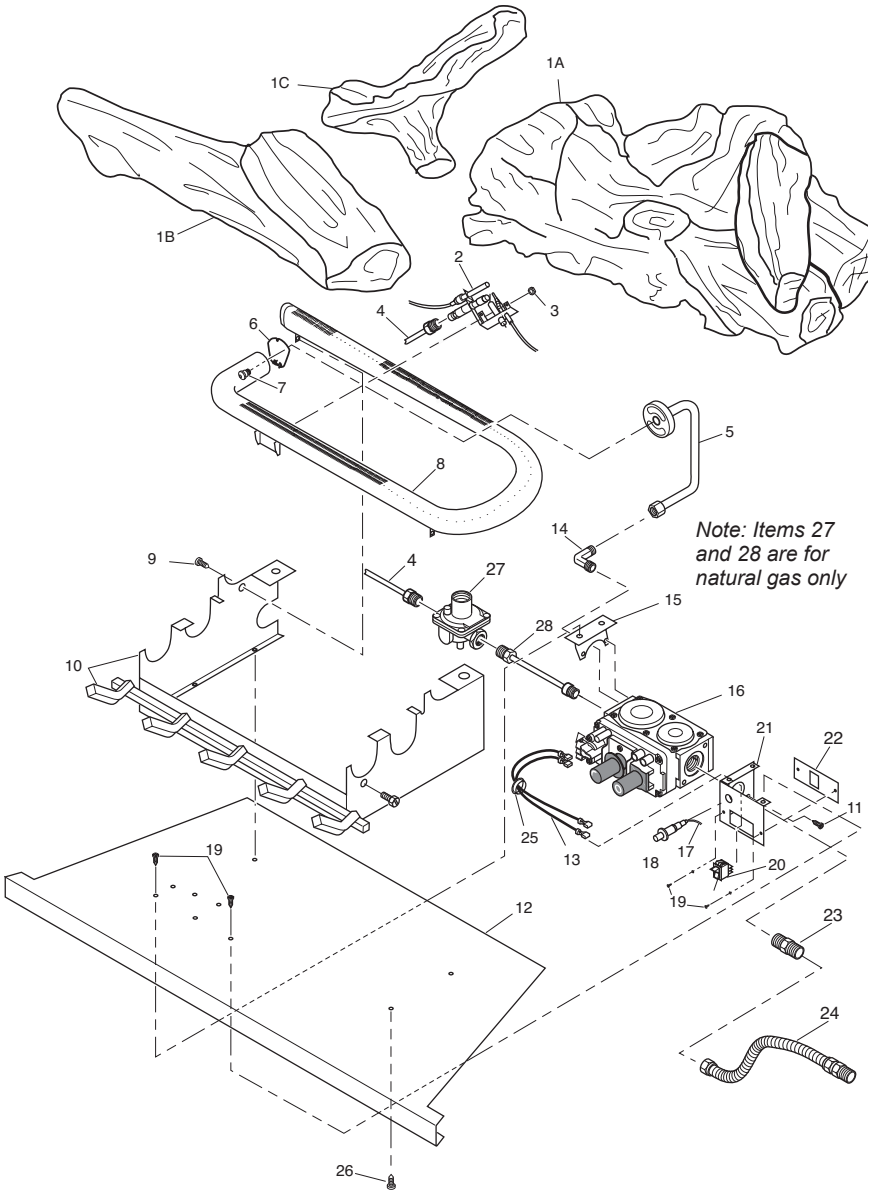

PARTS

This list contains replaceable parts used in your fireplace insert. When ordering parts, follow the instructions listed under Replacement Parts on page 29 of this manual.

KEY NO.	PART NO.	DESCRIPTION	V133NRB V133PRB		QTY.
			•	•	
1A	122081-04	Back Log	•	•	1
1B	122081-05	Front Log	•	•	1
1C	122081-06	Crossover Log	•	•	1
2	PP231	ODS Pilot	•	•	1
	PP235	ODS Pilot	•	•	1
3	098249-01	ODS Nut	•	•	2
4	099387-14	Pilot Tube	•	•	1
	099387-09	Pilot Tube	•	•	1
5	111331-13	Burner Outlet Tube	•	•	1
	104229-03	Burner Outlet Tube	•	•	1
6	111124-01	Burner Retainer Spring	•	•	1
7	099056-26	Burner Orifice Injector	•	•	1
	099056-19	Burner Orifice Injector	•	•	1
8	102772-01	Burner	•	•	2
9	M11084-38	Screw, #8 x 0.38	•	•	2
10	104236-01CK	Painted Base Assembly	•	•	1
11	M12461-26	Screw, #10 x 0.32	•	•	4
12	**	Firebox Bottom	•	•	1
13	103284-03	Wiring Harness	•	•	1
14	098265-02	Elbow, Male	•	•	1
15	103782-01	Valve Bracket	•	•	1
16	103781-01	Gas Control Valve	•	•	1
	103781-02	Gas Control Valve	•	•	1
17	098271-10	Ignitor Cable	•	•	1
18	102445-01	Piezo Ignitor	•	•	1
19	098304-01	Screw	•	•	7
20	099998-01	Switch	•	•	1
21	104241-01	Remote Switch Bracket	•	•	1
22	103587-01CK	Switch Plate	•	•	1
23	097809-02	Male Connector	•	•	1
24	101628-03	Flexible Connector (Hose)	•	•	1
25	M50104-02	Bushing	•	•	1
26	M11084-26	Screw, #10 x 0.38	•	•	4
27	099918-02	Pilot Regulator	•	•	1
28	099387-12	Pilot Tube (Valve to Regulator)	•	•	1
PARTS AVAILABLE — NOT SHOWN					
	103877-01	Lighting Instruction Plate	•	•	1
	100563-01	Warning Plate	•	•	1

** Not a field replacement part.

PARTS

FIREPLACE INSERT MODELS VI33NRB AND VI33PRB

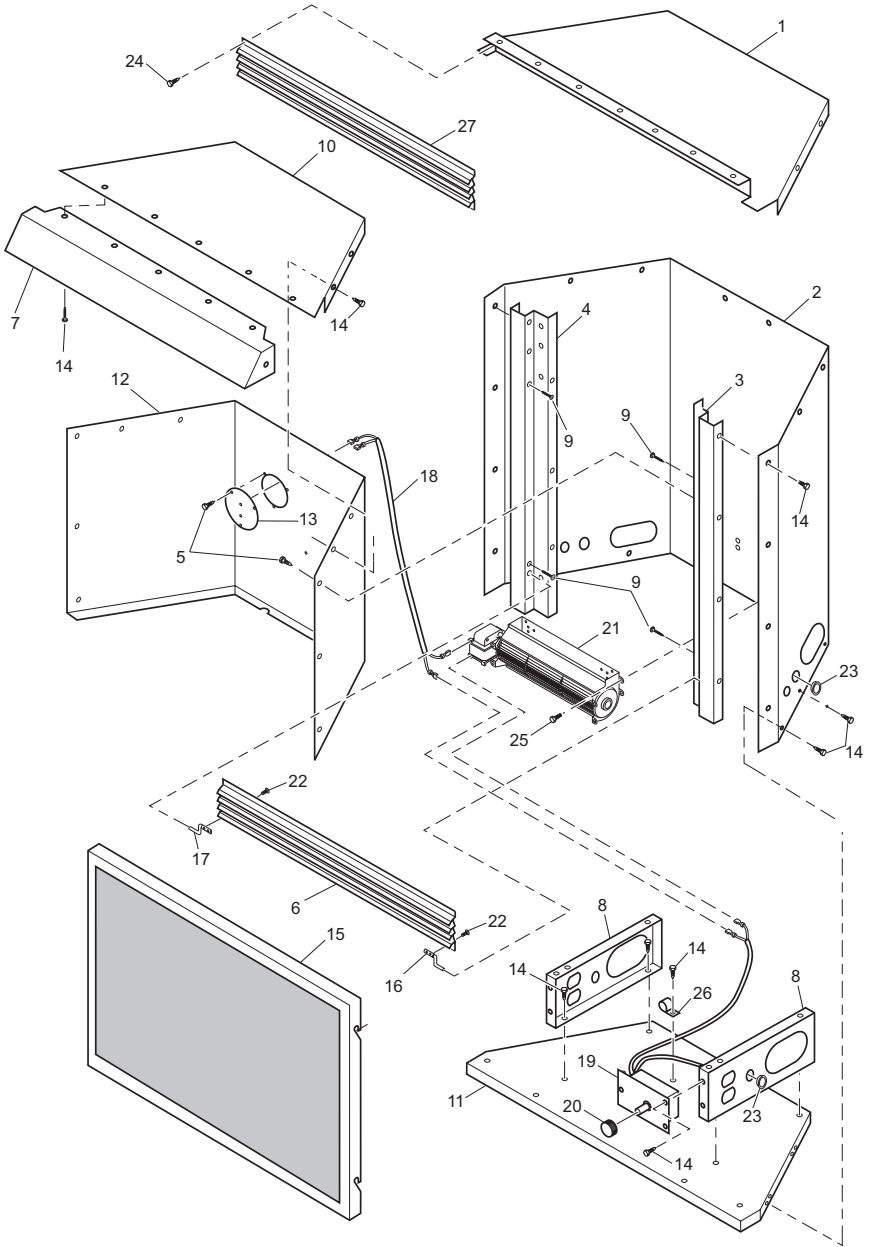

PARTS

FIREPLACE INSERT MODELS VI33NRB AND VI33PRB

This list contains replaceable parts used in your fireplace insert. When ordering parts, follow the instructions listed under Replacement Parts on page 29 of this manual.

KEY			
NO.	PART NO.	DESCRIPTION	QTY.
1	105517-01	Top Outer Casing	1
2	105233-01	Outer Casing	1
3	**	Right Front Side	1
4	**	Left Front Side	1
5	098304-01	Phillips Pan Head Screw, #10	9
6	102455-18	Louvered Door	1
7	105518-01CK	Firebox Hood	1
8	**	Firebox Support	2
9	099230-02	Shoulder Screw	4
10	**	Firebox Top	1
11	**	Outer Base	1
12	**	Firebox Wrapper	1
13	101614-02	Cover and Switch Assembly	1
14	M11084-26	Hex Screw, #10	46
15	105519-01CK	Screen Assembly	1
16	104313-01	Right Pin Hinge	1
17	104313-02	Left Pin Hinge	1
18	101398-03	Wiring Harness	1
19	105649-01	Blower Speed Control	1
20	103650-01	Knob	1
21	119943-01	Blower	1
22	M10908-2	Hex Washer Head Screw	4
23	101629-01	Plastic Bushing	2
24	098304-01	Phillips Pan Head Screw, #8	4
25	M11084-38	Hex Screw, #8	4
26	098544-01	Clamp	1
27	102455-22	Extruded Louver	1

** Not a field replacement part.

ACCESSORIES

Purchase these accessories from your local dealer. If they can not supply these accessories, either contact your nearest Parts Central or call DESA Heating, LLC at 1-866-672-6040 for information. You can also write to the address listed on the back page of this manual.

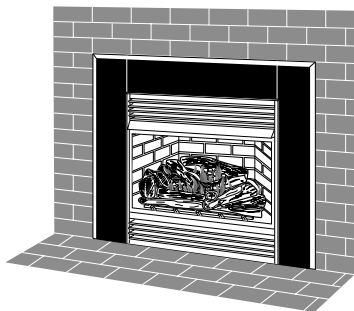

FIREPLACE SURROUND KIT (Surround Kit Required for Installation)

**GB38 - 30" H x 38" W Black Surround
with Black Trim**

**GS38 - 30" H x 38" W Black Surround
with Polished Brass Trim**

**GB43 - 36 3/4" H x 43" W Black Surround
with Black Trim**

**GS43 - 36 3/4" H x 43" W Black Surround
with Polished Brass Trim**

For all models. Allows insert to be fitted to fireplace opening. A surround is required for installation.

Note: Use the accessory which best covers the existing masonry fireplace opening.

- 38" Kit (for use with fireplaces with an opening smaller than 30" H and 38" W)
- 43" Kit (for use with fireplaces with an opening 30" to 36 3/4" H and 38" to 43" W)

LOUVER KIT

**GA9094 - Polished Brass (Includes Top
and Bottom Louvers)**

For all models.

FIREBOX BRICK LINER - G8010 Series

For all models. Your ceramic fiber firebox liner adds the look of real brick.

DUPLEX OUTLET KIT - GA3555

For built-in installation when accessory blowers are used.

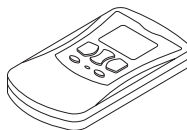

RECEIVER AND HAND-HELD THERMOSTAT REMOTE CONTROL KIT - HRC200 SERIES

For all models. Allows the gas log heater to be operated in a manually or thermostatically-controlled mode. You can turn the gas log heater on and off without ever leaving the comfort of your easy chair. A wall-mount docking station is included.

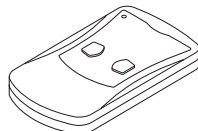

RECEIVER AND HAND-HELD REMOTE CONTROL KIT - HRC100 SERIES

For all models. Allows the gas log heater to be turned on and off by using a hand-held remote control. A wall-mount docking station is included.

ACCESSORIES

Continued

WALL-MOUNT THERMOSTAT SWITCH - GWMT1

For all models. The desired comfort setting can be selected on the wall thermostat and the log heater will automatically cycle from pilot to the heat setting selected.

WALL-MOUNT ON/OFF SWITCH GWMS2

For all models. Allows the gas log heater to be turned on and off with a wall switch.

CLEANING KIT - CCK

For all models. Your vent-free gas appliance requires regular cleaning and maintenance to prevent performance problems. This kit gives you the tools and instructions to make it easy to clean all critical areas of your appliance.

WARRANTY

KEEP THIS WARRANTY

Model (located on product or identification tag) _____

Serial No. (located on product or identification tag) _____

Date Purchased _____

Keep receipt for warranty verification.

DESA HEATING, LLC LIMITED WARRANTIES

New Products

Standard Warranty: DESA Heating, LLC warrants this new product and any parts thereof to be free from defects in material and workmanship for a period of four (4) years from the date of first purchase from an authorized dealer provided the product has been installed, maintained and operated in accordance with DESA Heating, LLC's warnings and instructions.

For products purchased for commercial, industrial or rental usage, this warranty is limited to 90 days from the date of first purchase.

Factory Reconditioned Products

Limited Warranty: DESA Heating, LLC warrants factory reconditioned products and any parts thereof to be free from defects in material and workmanship for 30 days from the date of first purchase from an authorized dealer provided the product has been installed, maintained and operated in accordance with DESA Heating, LLC's warnings and instructions.

Terms Common to All Warranties

The following terms apply to all of the above warranties:

Always specify model number and serial number when contacting the manufacturer. To make a claim under this warranty the bill of sale or other proof of purchase must be presented.

This warranty is extended only to the original retail purchaser when purchased from an authorized dealer, and only when installed by a qualified installer in accordance with all local codes and instructions furnished with this product.

This warranty covers the cost of part(s) required to restore this product to proper operating condition and an allowance for labor when provided by a DESA Heating, LLC Authorized Service Center or a provider approved by DESA Heating, LLC. Warranty parts must be obtained through authorized dealers of this product and/or DESA Heating, LLC who will provide original factory replacement parts. Failure to use original factory replacement parts voids this warranty.

Travel, handling, transportation, diagnostic, material, labor and incidental costs associated with warranty repairs, unless expressly covered by this warranty, are not reimbursable under this warranty and are the responsibility of the owner.

Excluded from this warranty are products or parts that fail or become damaged due to misuse, accidents, improper installation, lack of proper maintenance, tampering, or alteration(s).

This is DESA Heating, LLC's exclusive warranty, and to the full extent allowed by law; this express warranty excludes any and all other warranties, express or implied, written or verbal and limits the duration of any and all implied warranties, including warranties of merchantability and fitness for a particular purpose to four (4) years on new products and 30 days on factory reconditioned products from the date of first purchase. DESA Heating, LLC makes no other warranties regarding this product.

DESA Heating, LLC's liability is limited to the purchase price of the product, and DESA Heating, LLC shall not be liable for any other damages whatsoever under any circumstances including indirect, incidental, or consequential damages.

Some states do not allow limitations on how long an implied warranty lasts or the exclusion or limitation of incidental or consequential damages, so the above limitation or exclusion may not apply to you.

This warranty gives you specific legal rights, and you may also have other rights which vary from state to state.

For information about this warranty contact:



DESA Heating, LLC
2701 Industrial Drive
Bowling Green, KY 42101
www.desatech.com
1-866-672-6040



113195 01
NOT A UPC

113195-01
Rev. J
09/08