

LEXINGTON FORGE

DIRECT VENT GAS STOVE

INSTALLATION AND OPERATING INSTRUCTIONS

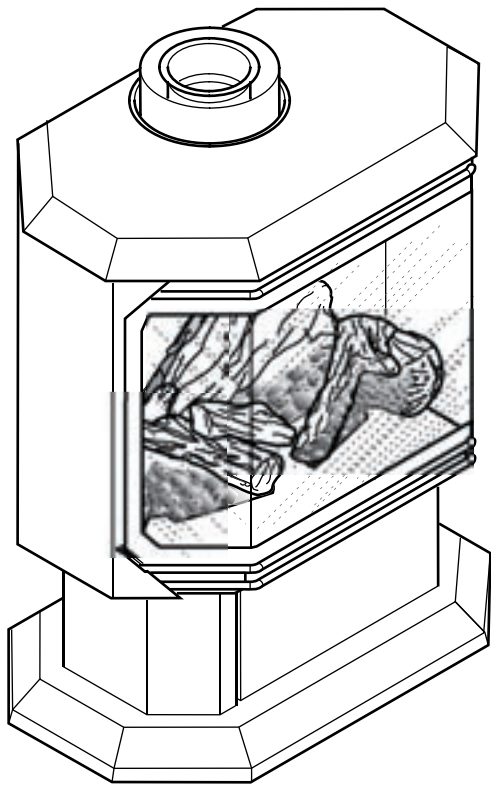

MODEL:
STRATFORD SS38DV



WARNINGS

IF THE INFORMATION IN THESE INSTRUCTIONS ARE NOT FOLLOWED EXACTLY, A FIRE OR EXPLOSION MAY RESULT CAUSING PROPERTY DAMAGE, PERSONAL INJURY OR LOSS OF LIFE.

- Do not store or use gasoline or other flammable vapors and liquids in the vicinity of this or any other appliance.
- WHAT TO DO IF YOU SMELL GAS
 - Do not try to light any appliance.
 - Do not touch any electrical switch; do not use any phone in your building.
 - Immediately call your gas supplier from a neighbor's phone. Follow the gas supplier's instructions.
 - If you cannot reach your gas supplier, call the fire department.
- Installation and service must be performed by a qualified installer, service agency or the gas supplier.

WARNING: Improper installation, adjustment, alteration, services or maintenance can cause injury or property damage. Refer to this manual. For assistance or additional information consult a qualified installer, service agency or the gas supplier.

This appliance is only for use with the type of gas indicated on the rating plate. This appliance is not convertible for use with other gases, unless a certified kit is used.

This appliance may be installed in an aftermarket*, permanently located, manufactured home, where not prohibited by local codes.

*Aftermarket: Completion of sale, not for purpose of resale, from the manufacturer.

DUE TO HIGH TEMPERATURES, THE APPLIANCE SHOULD BE LOCATED OUT OF TRAFFIC AND AWAY FROM FURNITURE AND DRAPERIES.

CHILDREN AND ADULTS SHOULD BE ALERTED TO THE HAZARDS OF HIGH SURFACE TEMPERATURE AND SHOULD STAY AWAY TO AVOID BURNS OR CLOTHING IGNITION.

YOUNG CHILDREN SHOULD BE SUPERVISED WHEN THEY ARE IN THE SAME ROOM AS THE APPLIANCE.

CLOTHING OR OTHER FLAMMABLE MATERIAL SHOULD NOT BE PLACED ON OR NEAR THE APPLIANCE.

KEEP THE ROOM AREA CLEAR AND FREE FROM COMBUSTIBLE MATERIALS, GASOLINE, AND OTHER FLAMMABLE VAPORS AND LIQUIDS.

READ BEFORE INSTALLING. SAVE THESE INSTRUCTIONS

CONTENTS

CONGRATULATIONS!

You have purchased a state-of-the-art gas appliance featuring the Lex-Fire Burn System available exclusively on Lexington Forge gas appliances.

The Lex-Fire Burn System sets a new standard for flame appearance through innovative log design, burner technology and ember placement. Each element effecting combustion and flame appearance was carefully scrutinized and strategically balanced during the design process to provide a product that was truly

“BORN TO BURN.”

Important Safety Information	3	Electrical Installation	24
Product Features	5	Electrical Wiring	24
Code Approval	5	Remote Wall Switch	24
Pre-Installation Information		Log Placement	25
Installing Above 2000 Feet.....	6	Operating Instructions	29
Orifice Sizes, Pressures and BTUs.....	6	What To Do If You Smell Gas.....	29
Stove Dimensions	6	Lighting Pilot for the First Time	29
Stove Location	6	Lighting Pilot	30
General Installation Information	7	Lighting Burner.....	30
Clearances	8	To Turn Off Gas.....	31
Vent Installation	9	Maintenance	32
Installation Precautions	9	Venting System	32
Installation Planning	10	Cleaning Glass.....	32
Installation for Horizontal Termination	13	Pilot and Burner Flames	32
Installation for Vertical Termination	17	Firebox Cleaning.....	32
Stove Installation		Air Shutter Adjustment	33
Check Gas Type.....	21	Glass Replacement	34
Installing Gas Piping to Stove/Burner System		Blower	35
Location	21	Replacement Parts	36
Checking Gas Pressure	23	Troubleshooting	38
Louver Installatoin	23	Warranty	Back Cover

IMPORTANT SAFETY INFORMATION

INSTALLER

Please leave these instructions with the owner.

OWNER

Please retain these instructions for future reference.

WARNING

- **Read this owner's manual carefully and completely before trying to assemble, operate, or service this stove.**
- **Any change to this stove or its controls can be dangerous.**
- **Improper installation or use of this stove can cause serious injury or death from fire, burns, explosions, electrical shock and carbon monoxide poisoning.**

This stove is a vented product. This stove must be properly installed by a qualified service person. The glass door must be properly seated and sealed. If this unit is not properly installed by a qualified service person with glass door properly seated and sealed, combustion leakage can occur.

CARBON MONOXIDE POISONING: Early signs of carbon monoxide poisoning are similar to the flu with headaches, dizziness and/or nausea. If you have these signs, the stove may not have been installed properly. Get fresh air at once! Have the stove inspected and serviced by a qualified service person. Some people are more affected by carbon monoxide than others. These include pregnant women, people with heart or lung disease or anemia, those under the influence of alcohol, and those at high altitudes.

Propane/LP gas and natural gas are both odorless. An odor-making agent is added to each of these gases. The odor helps you detect a gas leak. However, the odor added to these gases can fade. Gas may be present even though no odor exists.

Make certain you read and understand all warnings. Keep this manual for reference. It is your guide to safe and proper operation of this stove.

1. This appliance is only for use with the type of gas indicated on the rating plate. This appliance is not convertible for use with other gases unless a certified kit is used.
2. For propane/LP stove, do not place propane/LP supply tank(s) inside any structure. Locate propane/LP supply tank(s) outdoors. To prevent performance problems, do not use propane/LP fuel tank of less than 100 lbs. capacity.
3. If you smell gas
 - shut off gas supply.
 - do not try to light any appliance.
 - do not touch any electrical switch; do not use any phone in your building .
 - immediately call your gas supplier from a neighbor's phone. Follow the gas supplier's instructions.
4. Never install the stove
 - in a recreational vehicle
 - where curtains, furniture, clothing, or other flammable objects are less than 42" from the front, top, or sides of the stove
 - in high traffic areas
 - in windy or drafty areas
5. This stove reaches high temperatures. Keep children and adults away from hot surfaces to avoid burns or clothing ignition. Stove will remain hot for a time after shutdown. Allow surfaces to cool before touching.
6. Carefully supervise young children when they are in the room with stove.
7. Do not modify stove under any circumstances. Any parts removed for servicing must be replaced prior to operating stove.
8. Turn stove off and let cool before servicing, installing, or repairing. Only a qualified service person should install, service, or repair the stove. Have burner system inspected annually by a qualified service person.
9. You must keep control compartments, burners, and circulating air passages clean. More frequent cleaning may be needed due to excessive lint and dust from carpeting, bedding material, pet hair, etc. Turn off the gas valve and pilot light before cleaning stove.
10. Have venting system inspected annually by a qualified service person. If needed, have venting system cleaned or repaired. See *Cleaning and Maintenance*, page 31.
11. Keep the area around your stove clear of combustible materials, gasoline, and other flammable vapor and liquids. Do not run stove where these are used or stored. Do not place items such as clothing or decorations on or around stove.

Continued on page 4

IMPORTANT SAFETY INFORMATION

Continued from page 3

12. Do not use this stove to cook food or burn paper or other objects.
13. Never place anything on top of stove.
14. Do not use any solid fuels (wood, coal, paper, cardboard, etc.) in this stove. Use only the gas type indicated on rating plate.
15. This appliance, when installed, must be electrically grounded in accordance with local codes or in the absence of local codes, with the *National Electrical Code, ANSI/NFPA 70*, or the *Canadian Electrical Code, CSA C22.1*.
16. Do not obstruct the flow of combustion and ventilation air in any way. Provide adequate clearances around air openings into the combustion chamber along with adequate accessibility clearance for servicing and proper operation.
17. When the appliance is installed directly on carpeting, tile or other combustible material other than wood flooring, you must set appliance on a metal or wood panel or hearth pad extending the full width and depth of the appliance.
18. Do not use stove if any part has been exposed to or under water. Immediately call a qualified service person to arrange for replacement of the unit.
19. Do not operate stove if any log is broken.
20. Do not use a blower insert, heat exchanger insert, or other accessory not approved for use with this stove.
21. Do not operate the stove with glass door removed, cracked, or broken.

ATTENTION MASSACHUSETTS RESIDENTS:

This Lexington Forge product must be installed by a licensed gas fitter.

PRODUCT SPECIFICATIONS

- This appliance has been certified for use with either natural or propane gas. See appropriate data plates.
- This appliance is not for use with solid fuels.
- The appliance is approved for bedroom or bed sitting room installations.
- The appliance must be installed in accordance with local codes if any. If none exist use the current installation code. ANSI Z223.1/ NFPA 54 in the USA, CAN/CGA B149 in Canada.
- This appliance is mobile home approved.
- The appliance must be properly connected to a venting system.
- The appliance is not approved for closet or recessed installations.
- For alcove installation see "Clearances," page 8.

The efficiency rating of this appliance is a product thermal efficiency rating determined under continuous operating conditions and was determined independently of any installed system.

Thermal Efficiency = up to 80%

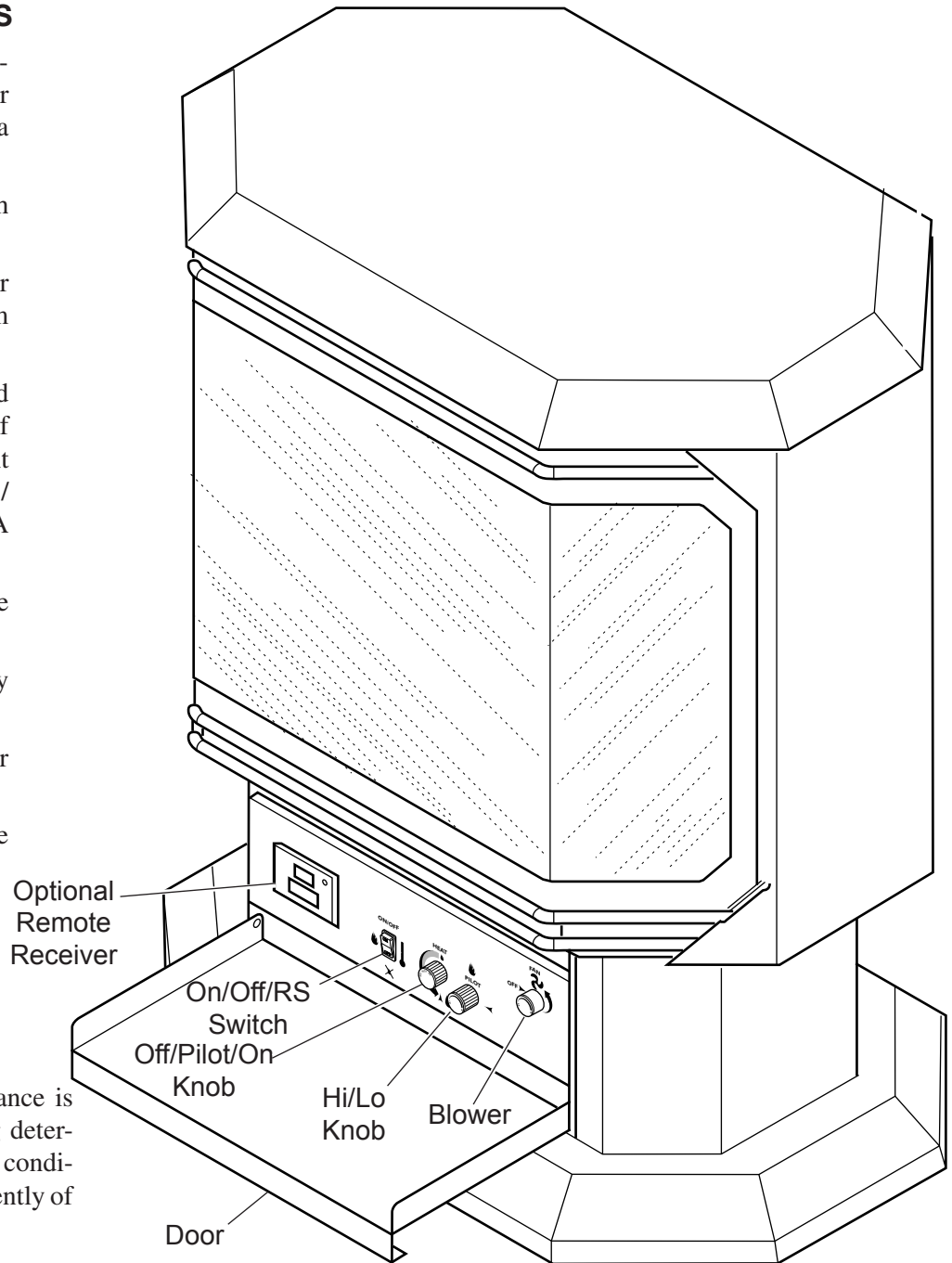

Figure 1 - SS38 Stove

CODE APPROVAL

Direct Vent type appliances draw all combustion air from outside of the dwelling through the vent pipe.

These appliances have been tested by CSA and found to comply with the established standards for DIRECT VENT GAS FIREPLACE HEATERS in the USA and Canada as follows:

LISTED VENTED GAS FIREPLACE HEATER
TESTED TO: ANSI Z21.88-2002/CSA 2.33-2002 STANDARDS

PRE-INSTALLATION INFORMATION

INSTALLING ABOVE 2000 FEET

- In the USA, the appliance must be derated 4% for every 1,000 ft above 2,000 ft elevations.
- In Canada, these appliances are certified for altitudes of 0 – 2000 ft, and must be de-rated by 10 percent for installations between 2000 and 4,500 ft. (derate an additional 4% for every 1,000 ft. above 4,500 ft. elevations).

ORIFICE SIZES, PRESSURES AND BTUs

NATURAL GAS

Manifold Press: (W.C.) 3.5"
 Maximum Supply Pressure 10.5"
 Minimum Supply Pressure 4.5"

PROPANE GAS

Manifold Press: (W.C.) 10"
 Maximum Supply Pressure 13"
 Minimum Supply Pressure 11"

Model Number	SS38	
	NATURAL	PROPANE
Max. Btu/hr Input	38000	35000
Min. Btu/hr Input	27000	25000
Orifice size (as shipped)	#32	#50

The STRATFORD SS38 is equipped with a variable output gas control.

STOVE DIMENSIONS

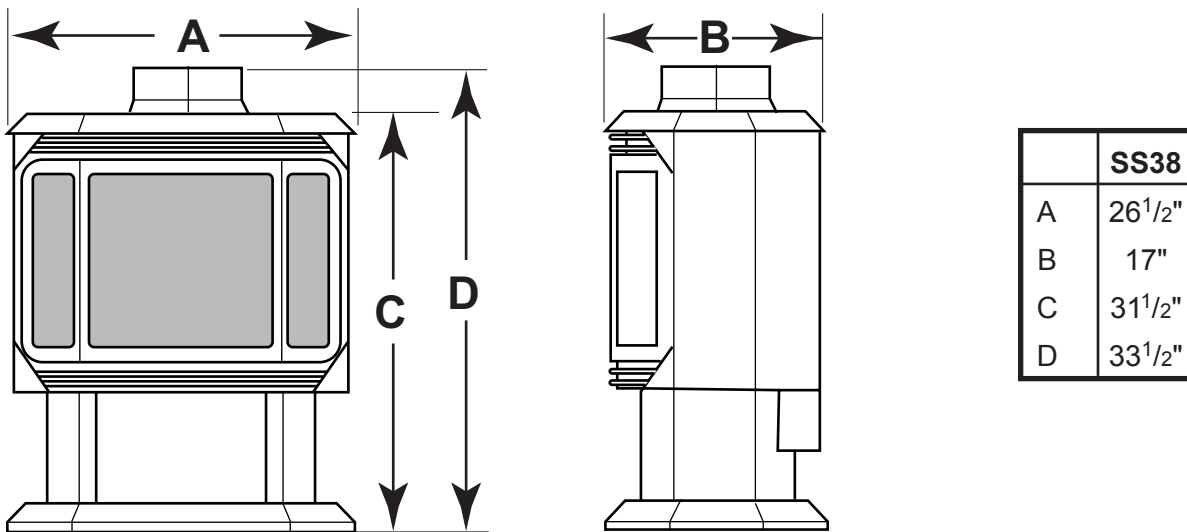

Figure 2 - External Stove Dimensions

NOTE: If this unit is installed in a mobile home it must be bolted securely to the floor with leg bolts.

NOTE: Stratford SS38 model stove works without any electrical supply.

STOVE LOCATION

Plan for the installation of your stove. This includes determining where the unit is to be installed, the vent configuration to be used, framing and finishing details, and whether any optional accessories (i.e. wall switch, or remote control) are desired. Consult your local building code agency to ensure compliance with local codes, including permits and inspections.

The following factors should be taken into consideration:

GENERAL INSTALLATION INFORMATION

- This stove should have sufficient access for its safe operation and maintenance.
- Locate a position where the flue system of the stove can be properly installed without damaging the integrity of the building (example: load-bearing framing members).
- When the appliance is installed directly on carpeting, tile or other combustible material other than wood flooring, you must set appliance on a metal or wood panel extending the full width and depth of the appliance.
- Check stove and flue system clearance requirements.
- Locate the stove where it can be accessed by a gas supply line.
- For optimal heat circulation and comfort, centrally locate the stove in a large and open room.
- The flow of combustion and ventilation air must not be obstructed.
- Minimum clearances to combustibles, side-wall, ceiling, woodwork, and windows **must be maintained**. See *Figures 4 and 5, page 8*.
- This stove may be installed along a wall, across a corner, or use an exterior chase. See *Figure 3* for suggested locations.
- Location should be out of high traffic areas and away from furniture and draperies due to heat from appliance.
- Never obstruct the front opening of the stove.
- Do **not** install in the vicinity where gasoline or other flammable liquids may be stored.
- Vent pipe routing. See *Venting* section found in this manual for allowable venting configurations.
- These units can be installed in a bedroom. See National Fuel Gas Code ANSI Z233.1/NFPA 54 (current edition), the Uniform Mechanical Code (current edition), and Local Building Codes for specific installation requirements.

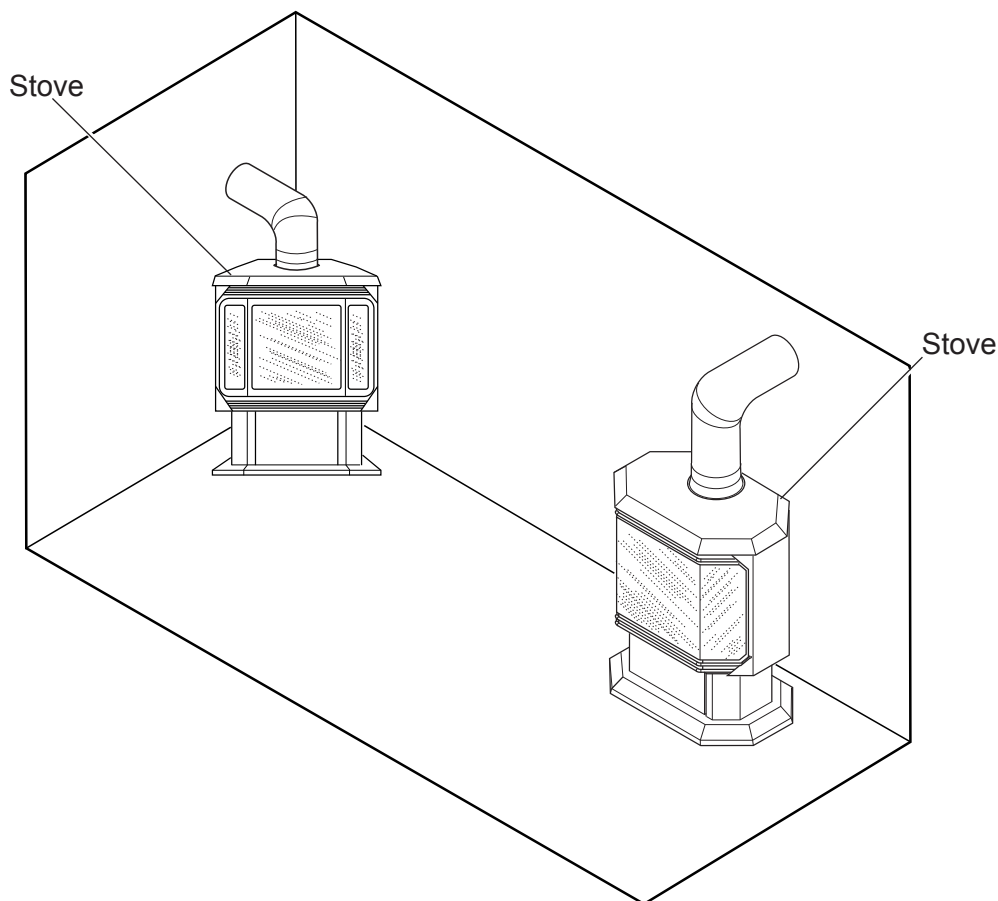

Figure 3 - Example of Typical Installations (see “Clearances,” page 8)

CLEARANCES

CLEARANCES TO COMBUSTIBLES

WARNING

The dimensions shown in *Figures 4 and 5* are minimum clearances to maintain in installing this heater. Left and right clearances are determined when facing the front of the heater.

Follow these instructions carefully to ensure safe installation. Failure to follow instructions exactly can create a fire hazard.

The appliance cannot be installed on a carpet, tile or other combustible material other than wood flooring. If installed on carpet or vinyl flooring, the appliance shall be installed on a metal, wood or noncombustible material panel extending full width and depth of the appliance.

Maintain the following minimum clearances for service and maintenance.

- Stove must be at least 6" from the back wall. *See Figure 4.*
- Stove must be at least 9" from either side wall. *See Figure 4.*
- Stove must be at least 6" from the corner. *See Figure 4.*
- No clearance is necessary to the floor. Stove may sit on the floor. *See Figure 5.*
- The minimum ceiling height from the floor must be 72".

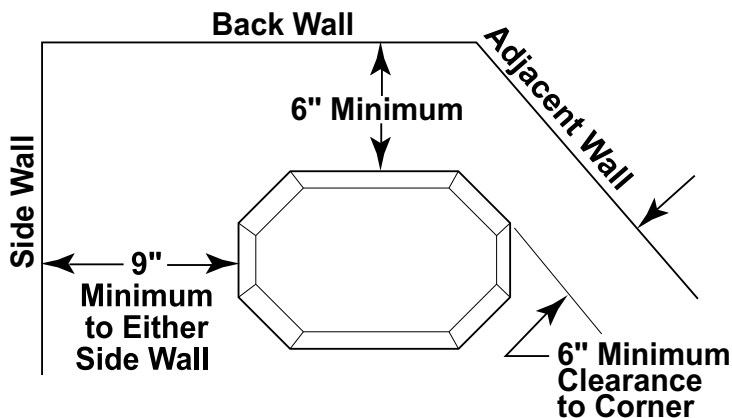

Figure 4 - Clearances to Side, Back and Adjacent Walls

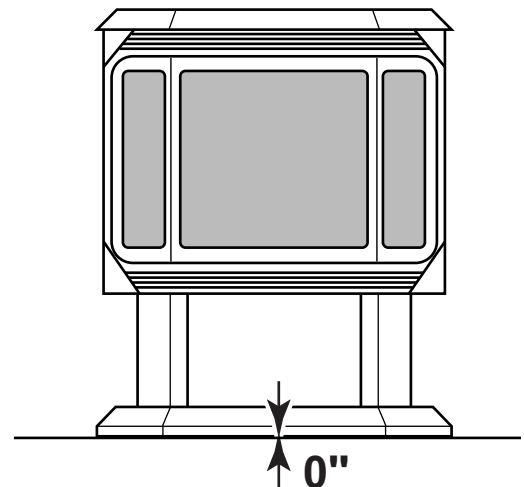

Figure 5 - Clearance to Floor

WARNING

Read all instructions completely and thoroughly before attempting installation. Failure to do so could result in serious injury, property damage or loss of life. Operation of improperly installed and maintained venting system could result in serious injury, property damage or loss of life.

NOTICE

Failure to follow these instructions will void the warranty.

INSTALLATION PRECAUTIONS

Consult local building codes before beginning the installation. The installer must make sure to select the proper vent system for installation. Before installing vent kit, the installer must read this stove manual and vent kit instructions.

Only a qualified installer/service person should install venting system. The installer must follow these safety rules:

- Wear gloves and safety glasses for protection.
- Use extreme caution when using ladders or when on rooftops.
- Be aware of electrical wiring locations in walls and ceilings.

The following actions will void the warranty on your venting system:

- Installation of any damaged venting component.
- Unauthorized modification of the venting system.
- Installation of any component part not manufactured or approved by Lexington Forge.
- Installation other than permitted by these instructions.

WARNING

This stove must be vented to the outside. The venting system must NEVER be attached to a chimney serving a separate solid fuel burning appliance. Each gas appliance must use a separate vent system. Do not use common vent systems.

WARNING

Horizontal sections of this vent system require a minimum clearance of 2" from the top of the pipe and 1" minimum to the sides and bottom. Vertical sections of this system require a minimum of 1" clearance to combustible materials on all sides of the pipe. *Only a 1" clearance is required where the vent passes through the nearest vertical wall.*

VENT INSTALLATION

INSTALLATION PLANNING

There are two basic types of direct-vent installation:

- Horizontal Termination
- Vertical Termination

It is important to select the proper length of vent pipe for the type of termination you choose. It is also important to note the wall thickness.

FOR HORIZONTAL TERMINATION

Select the amount of vertical rise desired. The horizontal run of venting must have $\frac{1}{4}$ " rise for every 12" of run towards the termination.

You may use up to three 90° elbows in this vent configuration. See *Horizontal Termination Configurations* on pages 15 and 16.

WARNING

Never run the vent pipe level or downward. This may cause excessive temperatures which could cause a fire.

FOR VERTICAL TERMINATION

Measure the distance from the stove flue outlet to the ceiling. Add the ceiling thickness, the vertical rise in an attic or second story, and allow for sufficient vent height above the roof line. You may use one or two 90° elbows in this vent configuration. See *Vertical Termination Configurations* on pages 19 and 20.

NOTE: You may use two 45° elbows in place of a 90° elbow. You must follow rise to run ratios when using 45° elbows. The appliance is approved for use with three 90° elbows maximum or a combination of 90° and 45° elbows up to a maximum of 270°.

For two-story applications, firestops are required at each floor level. If an offset is needed in the attic, additional pipe and elbows will be required.

You may use a chase with a vent termination with exposed pipe on the exterior of the house. See *Installing Vent System in a Chase* below.

It is very important that the venting system maintain its balance between the combustion air intake and the flue gas exhaust. Certain limitations apply to vent configurations and must be strictly followed.

INSTALLING A VENT SYSTEM IN AN OUTSIDE CHASE

A chase is a vertical boxlike structure built to enclose venting that runs along the outside of a building. A chase is required for such venting.

NOTICE

Treatment of firestops and construction of the chase may vary from building type to building type. These instructions are not substitutes for the requirements of local building codes. You must follow all local building codes.

NOTE: When installing in a chase, you should insulate the chase as you would the outside walls of your home. This is especially important in cold climates. Insulation should be considered a combustible material. Maintain proper clearances to all combustible materials.

FOR HORIZONTAL TERMINATION

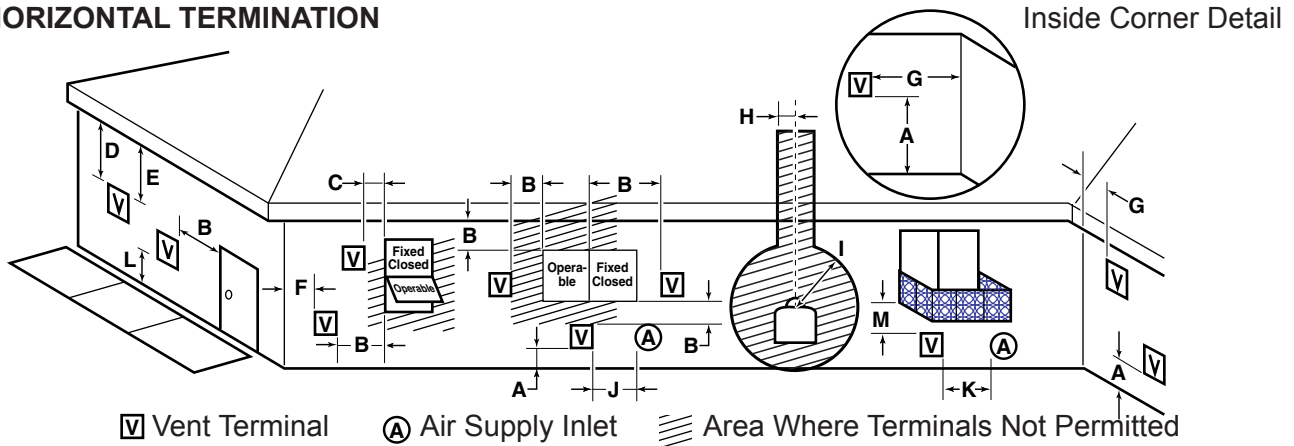

Figure 6 - Horizontal Vent Termination Location

MINIMUM DISTANCES

- A = Clearance above the grade, a veranda, porch, deck, or balcony [*12" (305mm) minimum].
 - B = Clearance to window or door that may be opened [*12" (305mm) minimum].
 - C = Clearance to permanently closed window [*minimum 12" (305mm) recommended to prevent condensation on window]
 - D = Vertical clearance to ventilated soffit located above the terminal within a horizontal distance of two (2) feet (610mm) from the centerline of the terminal [18" (457mm) minimum].
 - E = Clearance to unventilated soffits [12" (305mm) minimum]. **Clearance to vinyl soffit [30" (762mm)].**
 - F = Clearance to an outside corner. See page 12.
 - G = Clearance to an inside corner. See page 12.
 - H = *Not to be installed above a gas meter/regulator assembly within three (3) feet (914mm) horizontally from the centerline of the regulator.
 - I = Clearance to service regulator vent outlet [*3' (914mm) minimum].
 - J = Clearance to non-mechanical air supply inlet to building or the combustion air inlet to any other appliance [*12" (305mm) minimum].
 - K = Clearance to a mechanical air supply inlet [*6' (1829mm) minimum].
 - L = Clearance above a paved sidewalk or paved driveway located on public property [*7' (2133mm) minimum].
 - M = Clearance under veranda, porch, deck, or balcony [*12" (305mm) minimum ***].
 - N = Clearance above a roof shall extend a minimum of 24" (610mm) above the highest point when it passes through the roof surface and any other obstruction within a horizontal distance of 18" (457mm).
- * As specified in CAN/CGA B149 Installation Codes. Note: Local codes or regulations may require different clearances.
 - ** A vent must not terminate directly above a sidewalk or paved driveway, which is located between two single-family dwellings and serves both dwellings.
 - *** Only permitted if veranda, porch, deck, or balcony is fully open on a minimum of two sides beneath the floor.

WARNING

Always maintain minimum clearances around vent systems. The minimum clearances to combustibles for horizontal vent pipe are 2" at the top and 1" at the sides and bottom of the vent system until the pipe penetrates the nearest vertical wall. A 1" minimum clearance all around the pipe must be maintained. Do not pack the open air spaces with insulation or other materials. This could cause high temperatures and may present a fire hazard.

VENT INSTALLATION

TERMINATION CLEARANCES FOR BUILDINGS WITH COMBUSTIBLE AND NONCOMBUSTIBLE EXTERIORS

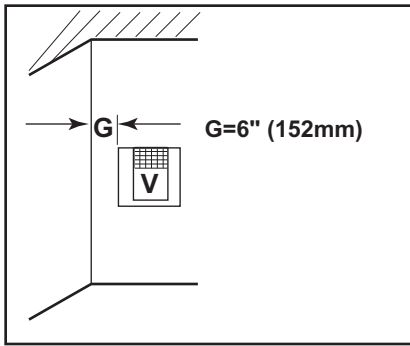

Inside Corner

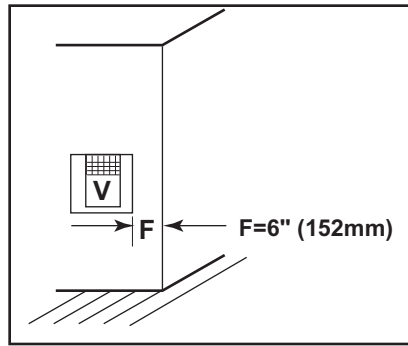

Outside Corner

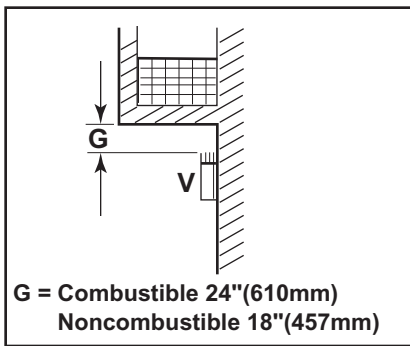

Balcony with No Side Wall

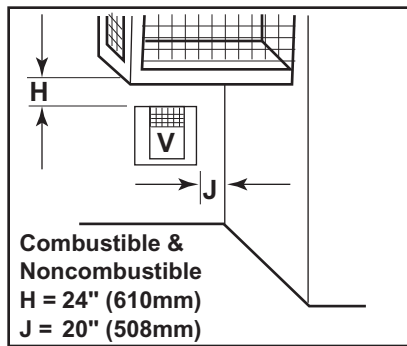

Balcony with Perpendicular Side Wall

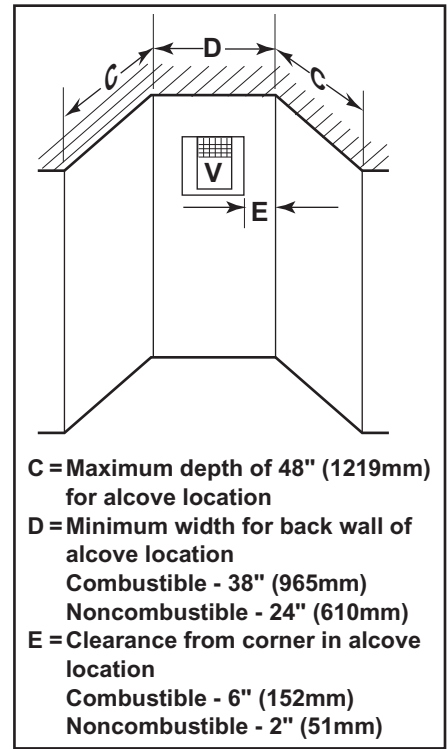

Alcove Location

Figure 7 - Allowable Venting Chart

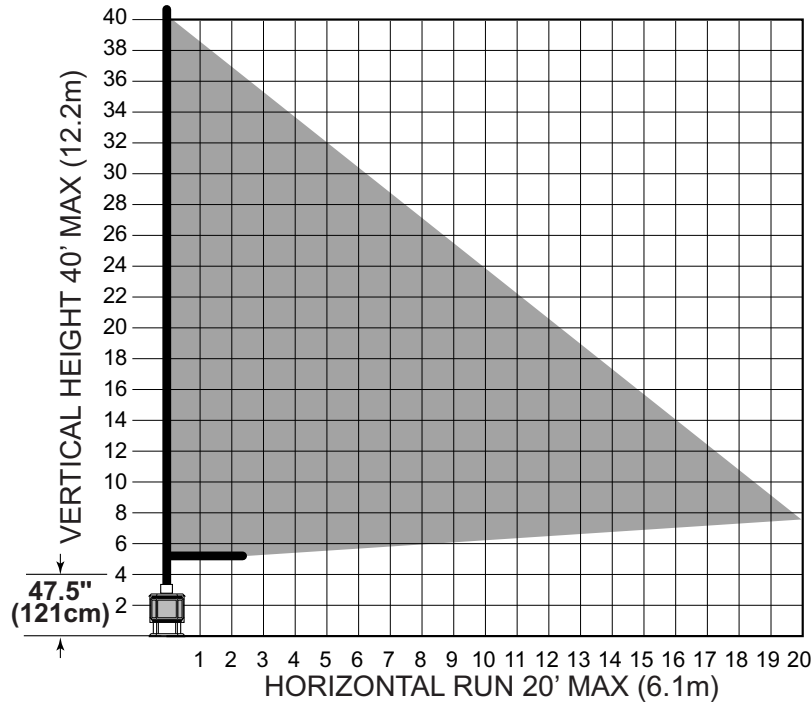

NOTE: Any vent configurations with the shaded areas are acceptable.

INSTALLATION FOR HORIZONTAL TERMINATION

1. Determine the route your horizontal venting will take.

Note: The location of the horizontal vent termination on the exterior wall must meet all local and national building codes.

Snorkel terminations are available for terminations requiring a vertical rise on the exterior of the building. See Figures 8 and 9. Follow the same installation procedures used for standard horizontal terminations. If installing the snorkel termination below grade (basement applications), you must provide proper drainage to prevent water from entering the snorkel termination. See Figure 9. Do not back fill around the snorkel termination.

WARNING
Do not recess vent terminal into a wall or siding.

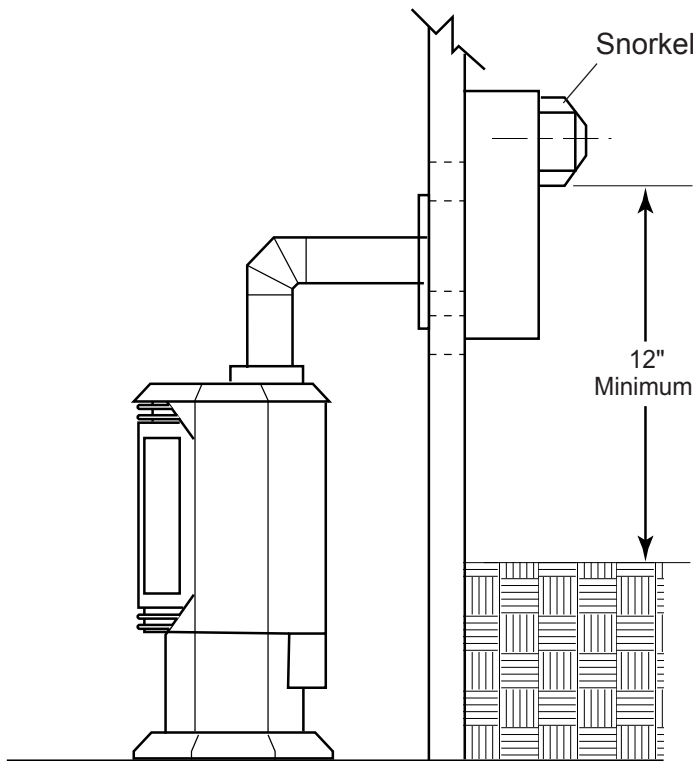

Figure 8 - Snorkel Termination

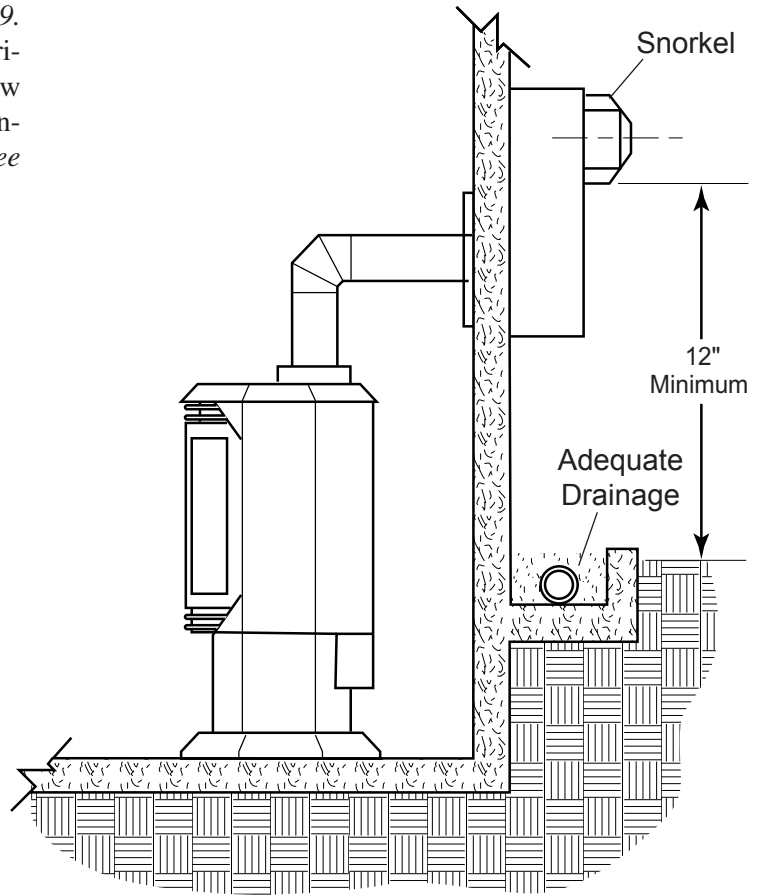
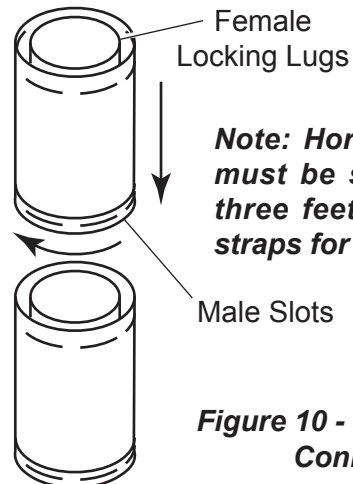

Figure 9 - Snorkel Termination with Drainage Pipe

2. Rigid vent pipes and fittings have special twist-lock connections. Assemble the desired combination of pipe and elbows to the appliance adaptor with pipe seams oriented towards the wall or floor.

Twist-lock Procedure: The female ends of the pipes and fittings have three locking lugs (indentations). These lugs will slide straight into matching slots on the male end of adjacent pipes and fittings. Push the pipe sections together and twist one section clockwise approximately one-quarter turn until the sections are fully locked. See Figure 10.



Note: Horizontal runs of vent must be supported every (3) three feet (914mm). Use wall straps for this purpose.

Figure 10 - Rigid Vent Pipe Connections

Continued

VENT INSTALLATION

HORIZONTAL VENT INSTALLATION (continued)

- Attach vent pipe assembly to the stove. Set stove in front of its permanent location to insure minimum clearances. Mark the wall for a 9 1/2" (241) square hole (for noncombustible material such as masonry block or concrete, a 7 1/2" [190mm] diameter hole is acceptable). See Figure 11. The center of the hole should line up with the center line of the horizontal rigid vent pipe end. Be sure to allow for minimum rise. Cut a 9 1/2" x 9 1/2" (241mm X 241mm) square hole through combustible exterior wall (7 1/2" [190mm] diameter hole if noncombustible). Frame as necessary. See Figure 11.
- Apply a bead of non-hardening mastic around the outside edge of vent cap. Position the vent cap in the center of the 7 1/2" (190mm) or 9 1/2" (241mm) hole on the exterior wall with the word "UP" on the vent cap facing up. Insure proper clearance of 1" to combustibles is maintained. Attach the vent cap with four wood screws supplied. See Figure 12.

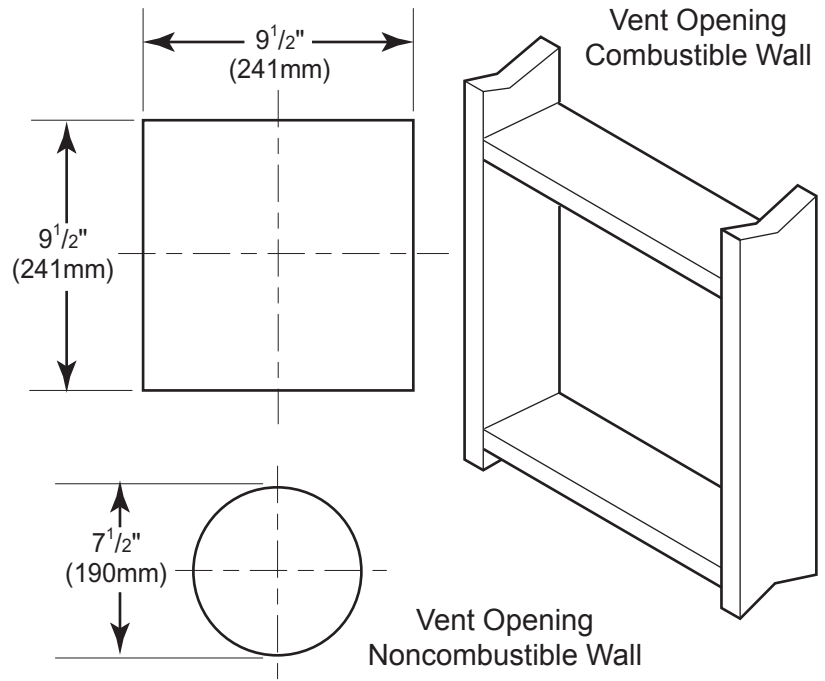

Figure 11 - Vent Opening Requirements

NOTE: Replace the wood screws with appropriate fasteners for stucco, brick, concrete, or other types of siding.

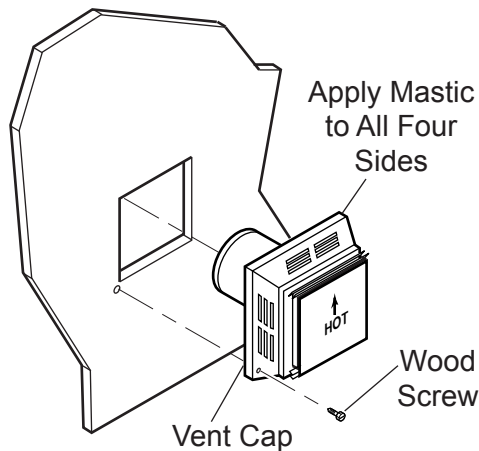

Figure 12 - Installing Horizontal Vent Cap

For vinyl siding, stucco, or wood exterior use vinyl siding standoffs between vent cap and exterior wall. The vinyl siding standoff prevents excessive heat from melting the vinyl siding material. Bolt the vent cap to the standoff. Apply non-hardening mastic around outside edge of the standoff instead of the vent cap assembly. Use wood screws provided to attach the standoff. See Figure 13.

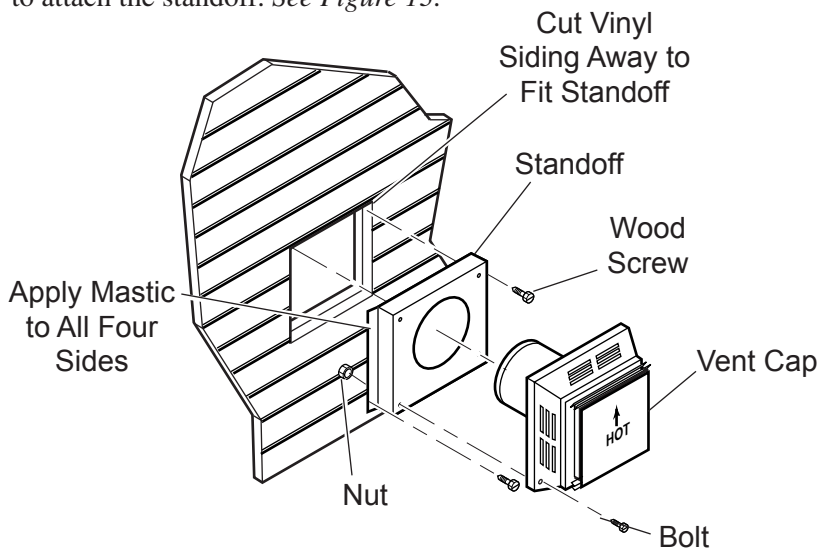

Figure 13 - Installing Vinyl Siding Standoff

WARNING

Do not recess vent termination into any wall. This will cause a fire hazard.

Continued

HORIZONTAL VENT INSTALLATION (CONTINUED)

5. Slide the wall thimble over the vent pipe before connecting the horizontal run to the vent cap. *See Figure 14.*
6. Carefully move the stove with vent assembly attached toward the wall and insert the vent pipe into the horizontal termination. The pipe overlap should be a minimum of 1¹/₄" (mm). Apply silicone to the outer pipe connection. Fasten all vent connections with screws provided.
7. Slide the wall thimble against the interior wall surface and attach with screws. *See Figure 14.*

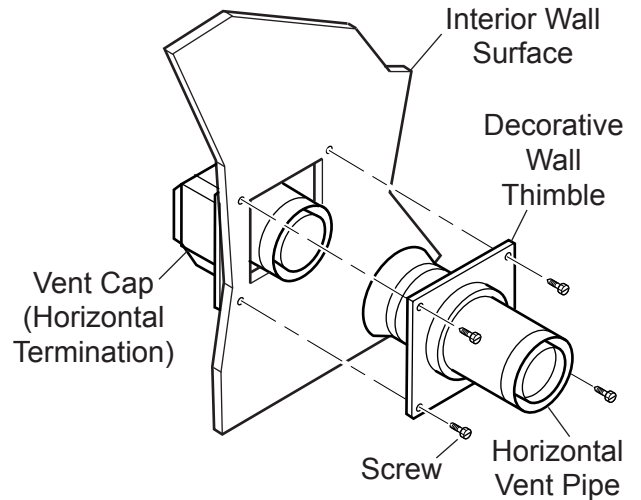

Figure 14 - Connecting Vent Cap with Horizontal Vent Pipe

HORIZONTAL TERMINATION CONFIGURATIONS

Figures 15 through 17 show different configurations for venting with horizontal termination. Each figure includes a chart with vertical minimum/maximum and horizontal maximum dimensions which must be met. All horizontal terminations require a 1/4" rise per 12" of horizontal run.

NOTE: Add 1/4" rise per 12" horizontal length of pipe.

Vertical (V)	Horizontal (H)
62" minimum	31" maximum
72 ¹ / ₂ " minimum	8' maximum
98" minimum	20' maximum

Table 2 - Horizontal Venting

NOTE: This configuration is for use with corner installation also.

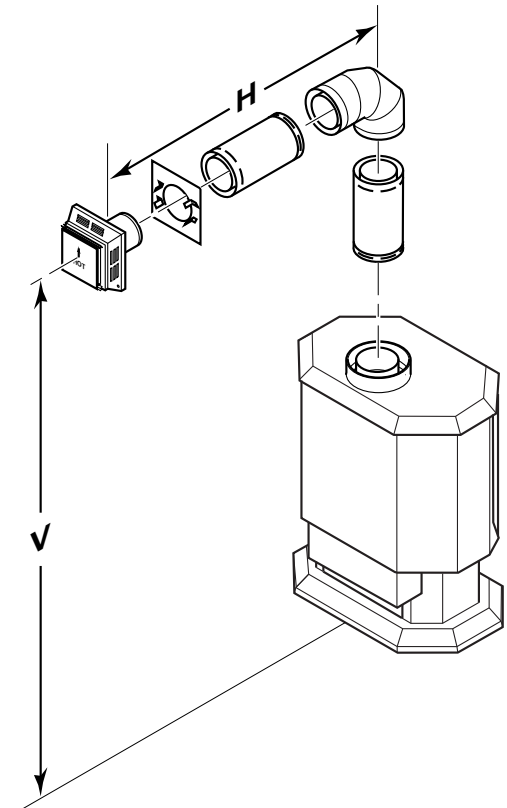
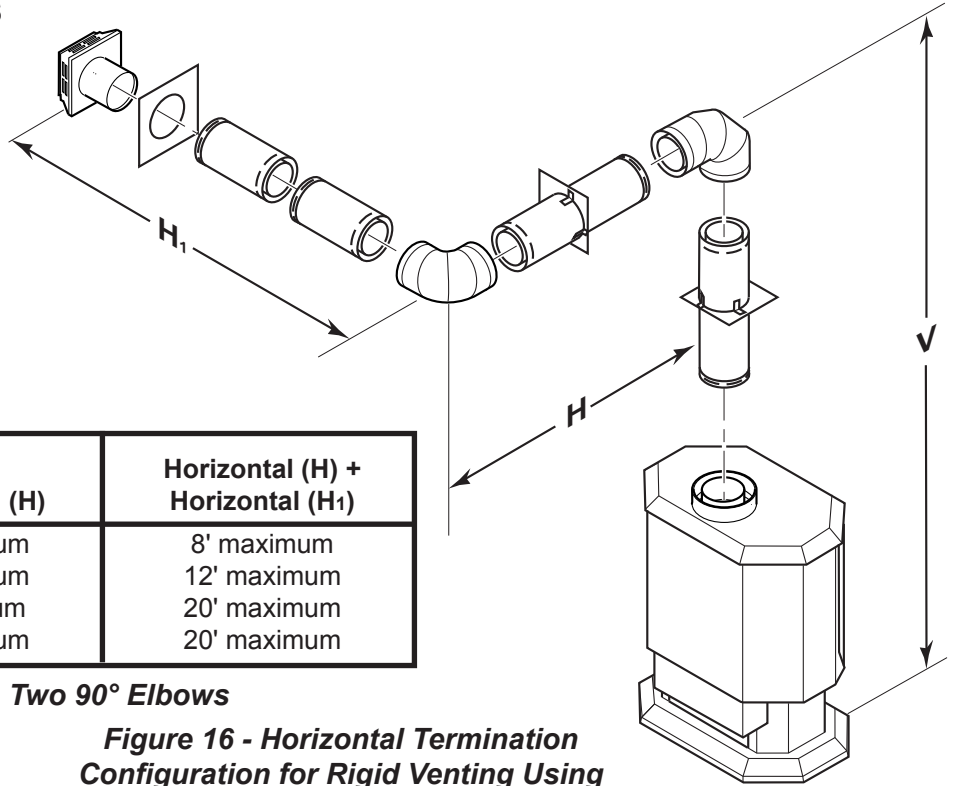

Figure 15 - Horizontal Termination Configuration for Rigid Venting Using One 90° Elbow

VENT INSTALLATION

VENTING WITH TWO 90° ELBOWS

NOTE: Add 1/4" rise per 12" horizontal length of pipe.



Vertical (V)	Horizontal (H)	Horizontal (H) + Horizontal (H1)
5' minimum	4' maximum	8' maximum
6' minimum	6' maximum	12' maximum
7' minimum	8' minimum	20' maximum
20' maximum	8' maximum	20' maximum

Table 2 - Venting with Two 90° Elbows

Figure 16 - Horizontal Termination Configuration for Rigid Venting Using Two 90° Elbows

VENTING WITH THREE 90° ELBOWS

NOTE: Add 1/4" rise per 12" horizontal length of pipe.

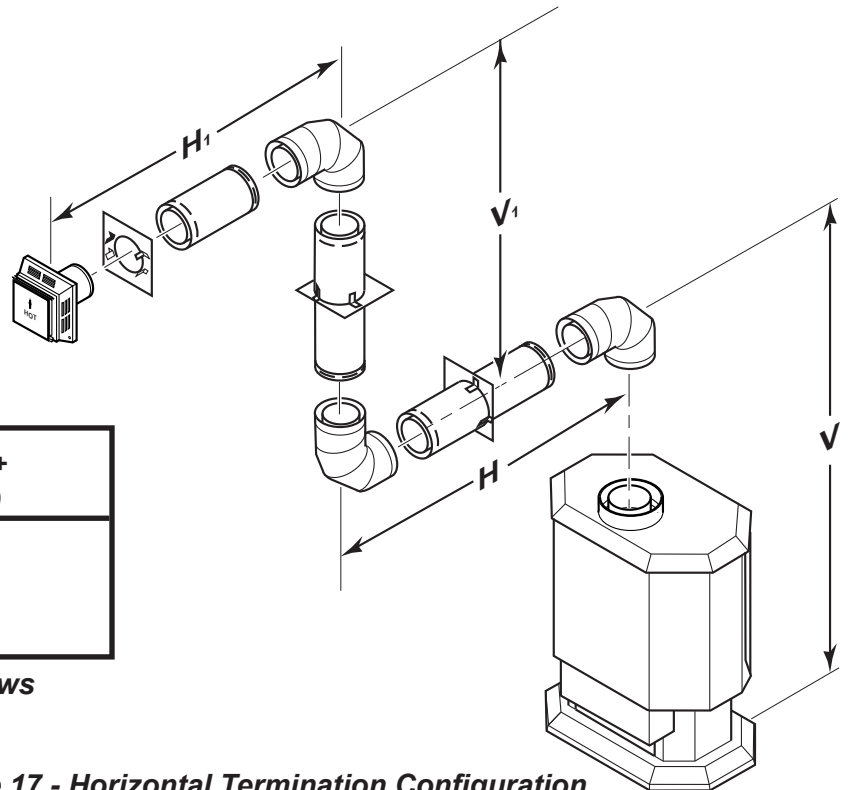

Vertical (V) + (V1)	Horizontal (H) + Horizontal (H1)
5' minimum	4' maximum
6' minimum	6' maximum
8' minimum	10' maximum
20' maximum	12' maximum

Table 3 - Venting with Three 90° Elbows

Figure 17 - Horizontal Termination Configuration for Rigid Venting Using Three 90° Elbows with Termination at 90° with Stove

INSTALLATION FOR VERTICAL TERMINATION

1. Determine the route your vertical venting will take. If ceiling joist, roof rafters or other framing will obstruct the venting system, consider an offset. See Figure 18 to avoid cutting load bearing members.

NOTE: Payspecial attention to these installation instructions for required clearances (air space) to combustibles when passing through ceilings, walls, roofs, enclosures, attic rafters, etc. Do not pack air spaces with insulation. Also note maximum vertical rise of the venting system and any maximum horizontal offset limitations. Offsets must fall within the parameters shows in Figure 7 on page 12.

2. Set stove in desired location. Drop a plumb line down from the ceiling to the position of the burner system exit flue. Mark the center point where the vent will penetrate the ceiling. Drill a small locating hole a this point.

Drop a plumb line from the inside of the roof to the locating hole in the ceiling. Mark the center point where the vent will penetrate the roof. Drill a small locating hole at this point.

FLAT CEILING INSTALLATION

1. Cut a 9¹/₂" (241 mm) square hole in the ceiling using the locating hole as a center point The opening should be framed to 9¹/₂"x9¹/₂" (241mm x 241mm) inside dimensions as shown in Figure 20 using framing lumber the same size as the ceiling joist. If the area above the ceiling is an insulated ceiling or a room, nail firestop from the top side. This prevents loose insulation from falling into the required clearance space. See Figure 19. Otherwise, install firestop below the framed hole. The firestop should be installed with no less than three nails per side. See Figure 20.
2. Assemble the desired lengths of pipe and elbows necessary to reach from the burner system flue up through the firestop. Be sure pipe and elbow connections are fully twist-locked. See Figure 10, page 13.
3. Cut a hole in the roof using the locating hole as a center point. (Cover any exposed open vent pipes before cutting hole in roof). The 9¹/₂"x9¹/₂" (241 mm x 241mm) hole must be measured on the horizontal. Actual length may be larger depending on the pitch of the roof. There must be a 1" minimum clearance from the vent pipe to combustible materials. (Insulation should be considered a combustible material) Frame the opening as shown in Figure 11 on page 14.

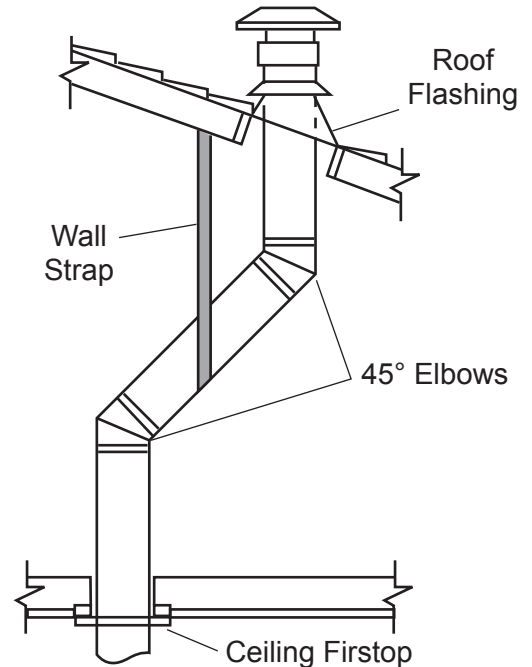

Figure 18 - Offset with Wall Strap and 45° Elbows

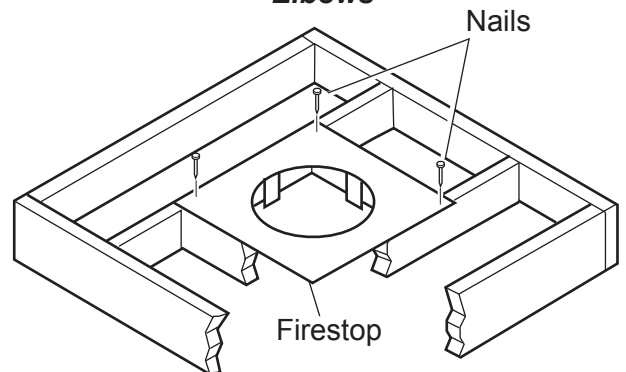

Figure 19 - If area above is a room, install firestop above framed hole as shown

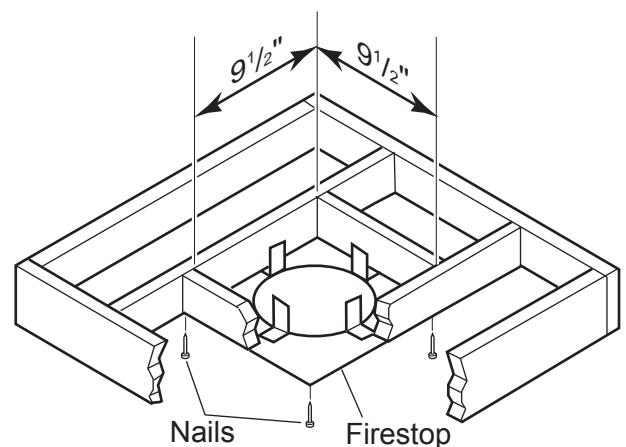

Figure 20 - If area above is not a room, install firestop below framed hole as shown

Continued on next page

VENT INSTALLATION

4. Connect a section of pipe and extend up through the hole.

NOTE: If an offset is needed to avoid obstructions, you must support the vent pipe every three (3) feet. Use wall straps for this purpose. See Figure 18, page 17. Whenever possible, use 45° elbows instead of 90° elbows. The 45° elbow offers less restriction to the flow of the flue gases and intake air.

5. Place the flashing over the pipe section(s) extending through the roof. Secure the base of the flashing to the roof and framing with roofing nails. Be sure roofing material overlaps the top edge of the flashing as shown in Figure 18, page 17. There must be a 1" clearance from the vent pipe to combustible materials.

6. Continue to add pipe sections until the height of the vent cap meets the minimum building code requirements.

NOTE: You must increase vent height for steep roof pitches. Nearby trees, adjoining roof lines, steep pitched roofs, and other similar factors may cause poor draft or down-drafting in high winds. Increasing the vent height may solve this problem.

NOTE: If the vent pipe passes through any occupied areas above the first floor, including storage spaces and closets, you must enclose pipe. You may frame and sheetrock the enclosure with standard construction material. Make sure to meet the minimum allowable clearances to combustibles. Do not fill any of the required air spaces with insulation.

CATHEDRAL CEILING INSTALLATION

IMPORTANT: Review all information on previous page before planning this installation. Cathedral ceiling installations can be very tricky.

1. Remove shingles or other roof covering as necessary to cut the rectangular hole for the support box. Mark the outline of the cathedral ceiling support box on the roof sheathing using the locating hole as a center point.
2. Cut the hole $\frac{1}{8}$ " larger than the support box outline. See Figure 21.
3. Lower the support box through the hole in the roof until the bottom of the box extends at least 2" (mm) below the ceiling. See Figure 21. Align the support box vertically and horizontally using a level. Temporarily tack the support box in place through the inside walls and into the roof sheathing.
4. Using tin snips, cut the support box from the top corners down to the roofline and fold the resulting flaps over the roof sheathing. See Figure 22. Apply a bead of non-hardening mastic around the top edges of the support box to make a seal between the box and the roof. Nail in place with roofing nails. Remove any combustible material that might be inside the support box.
5. Complete the cathedral ceiling installation by following the same procedures outlines in steps 2 through 6 for *Flat Ceiling Installation*, page 17 and above.

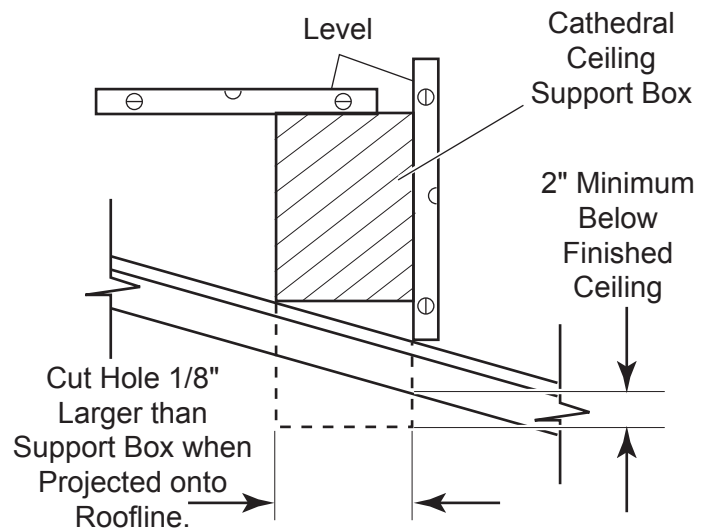

Figure 21 - Cathedral Ceiling Support Box Installation

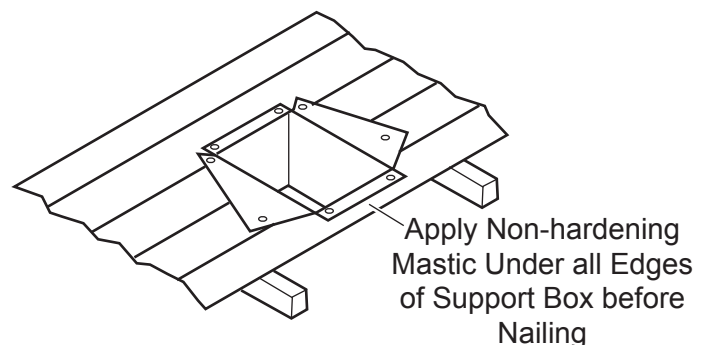

Figure 22 - Installed Cathedral Ceiling Support Box

VERTICAL TERMINATION CONFIGURATIONS

Figures 23 through 26 on pages 19 and 20 show four different configurations for vertical termination.

IMPORTANT: You must install a restrictor on all vertical installations.

NOTE: Install restrictor into 4" collar of stove or first vent section as shown.

Vertical (V)	Horizontal (H)
8' minimum	2' maximum
9' minimum	4' maximum
10' minimum	6' maximum
11' minimum	8' maximum
23' maximum	8' maximum

Table 5 - Venting with Two 90° Elbows

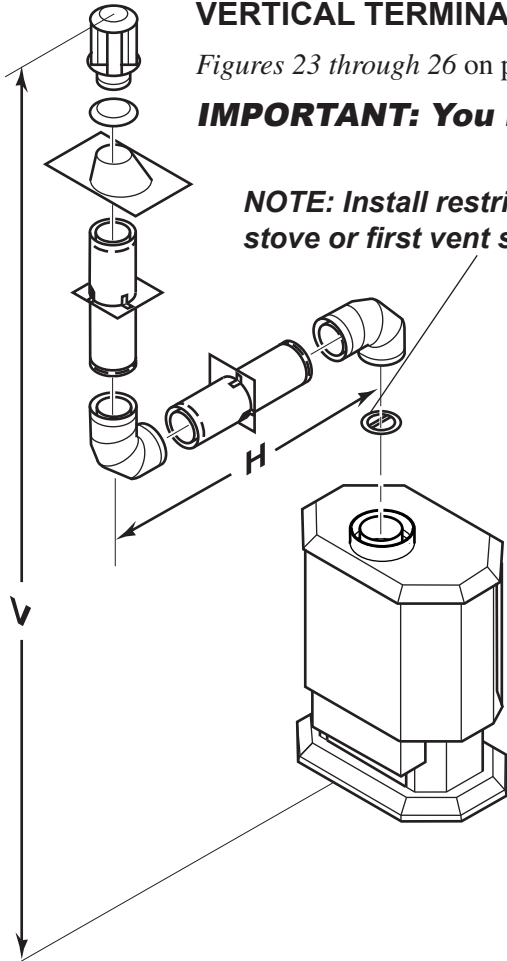

Figure 23 - Vertical Rigid Venting Configuration Using Two 90° Elbows

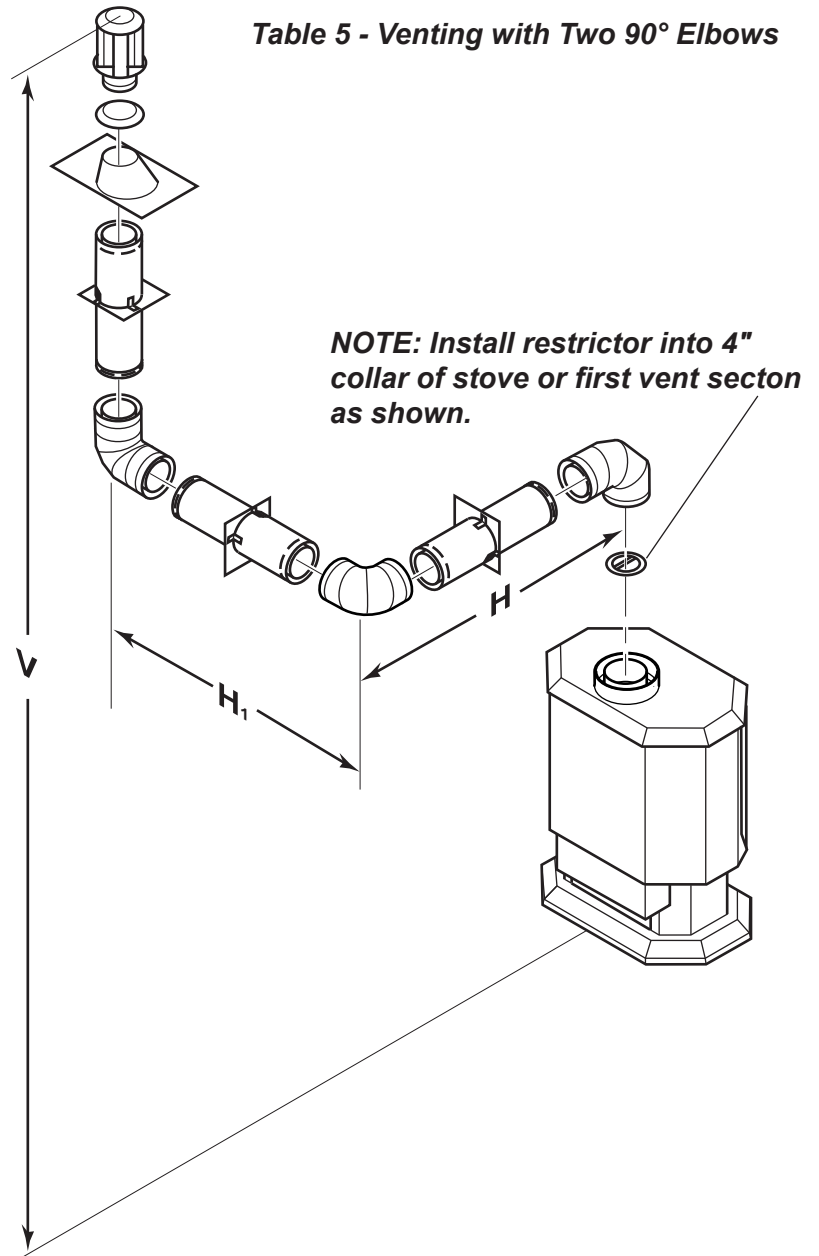

Figure 24 - Vertical Rigid Venting Configuration Using Three 90° Elbows with Two Horizontal Runs

Vertical (V)	Horizontal (H) + Horizontal (H ₁)
8' minimum	2' maximum
9' minimum	4' maximum
10' minimum	6' maximum
11' minimum	8' maximum
23' maximum	8' maximum

Table 6 - Venting with Three 90° Elbows

VENT INSTALLATION

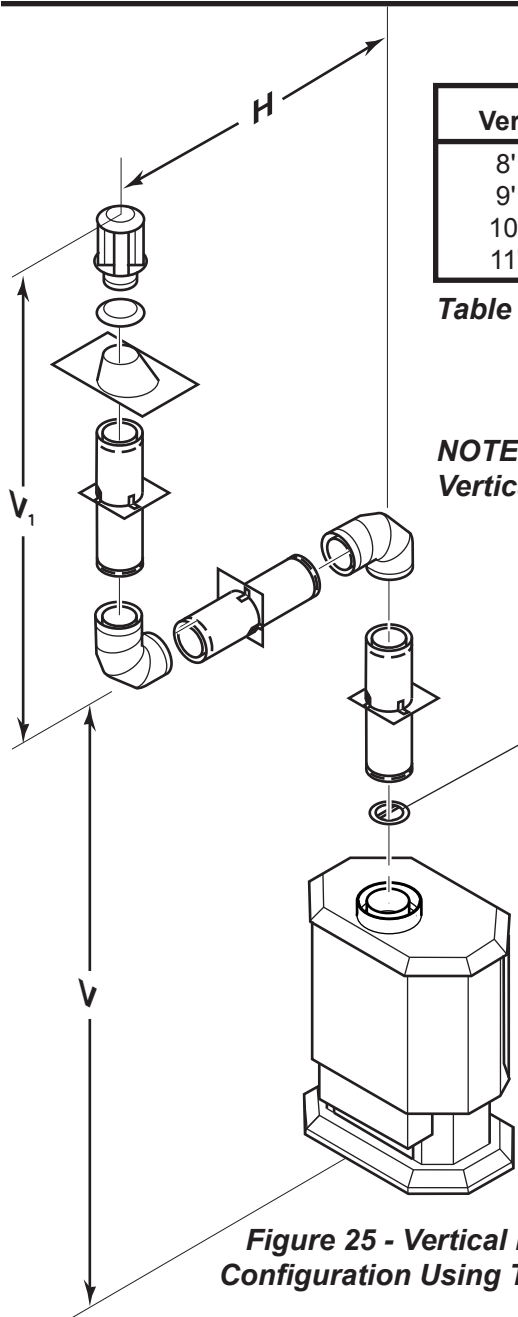

Figure 25 - Vertical Rigid Venting Configuration Using Two 90° Elbows

Vertical (V+V1)	Horizontal (H)
8' minimum	6' maximum
9' minimum	12' maximum
10' minimum	18' maximum
11' minimum	20' maximum

Table 7 - Venting with Two 90° Elbows

NOTE:
Vertical (V₁) + Vertical (V₂) = 20' Maximum

NOTE: Install restrictor into 4" collar of stove or front vent section as shown.

Vertical Venting
V = 40' maximum

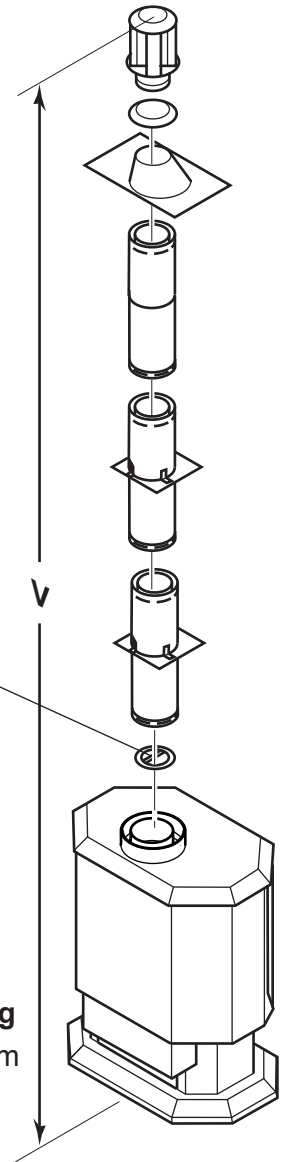

Figure 26 - Vertical Rigid Venting Configuration with No Horizontal run

SIMPSON DURA-VENT GS 4" X 6 5/8" (BLACK PIPE)

NUMBER	DESCRIPTION	NUMBER	DESCRIPTION
902B	7" x 48" Pipe	943S	Roof Flashing 7/12-12/12
903B	7" x 36" Pipe	945B	7" x 45° Elbow
904B	7" x 24" Pipe	950	Vinyl siding Standoff
906B	7" x 12" Pipe	953	Storm Collar
907B	7" x 9" Pipe	963	Ceiling Firestop
908B	7" x 6" Pipe	981	36" Snorkel Termination
911B	7" Adjustable (11" - 14 5/8" Pipe)	984	Horizontal Termination Vent Cap
940	Wall Thimble	988	Wall Strap
941	Cathedral Ceiling Support Box	990B	7" x 90° Elbow
943	Roof Flashing 0/12-6/12	991	Vertical High Wind Termination

Table 8

CHECK GAS TYPE

Use proper gas type for the stove you are installing. If you have conflicting gas type, do not install stove. See dealer where you purchased the stove for proper stove for your gas type or conversion kit.

INSTALLING GAS PIPING TO STOVE / BURNER SYSTEM LOCATION

WARNING

A qualified installer or service person must connect appliance to gas supply. Follow all local codes.

CAUTION

For propane/LP units, never connect stove directly to the propane/LP supply. This burner system requires an external regulator (not supplied). Install the external regulator between the burner system and propane/LP supply.

INSTALLATION ITEMS NEEDED

Before installing stove and burner system, make sure you have the items listed below.

- External regulator (supplied by installer)
- Piping (check local codes)
- Sealant (resistant to propane/LP gas)
- Equipment shutoff valve*
- Test gauge connection*
- Sediment trap
- Tee joint
- Pipe wrench
- approved flexible gas line with gas connector (if allowed by local codes — not provided)

* A CSA design-certified equipment shutoff valve with $\frac{1}{8}$ " NPT tap is an acceptable alternative to test gauge connection. Purchase the CSA design-certified equipment shutoff valve from your dealer.

For propane/LP connections only, the installer must supply an external regulator. The external regulator will reduce incoming gas pressure. You must reduce incoming gas pressure to between 11 and 13 inches of water. If you do not reduce incoming gas pressure, burner system regulator damage could occur. Install external regulator with the vent pointing down as shown in *Figure 27*. Pointing the vent down protects it from freezing rain or sleet.

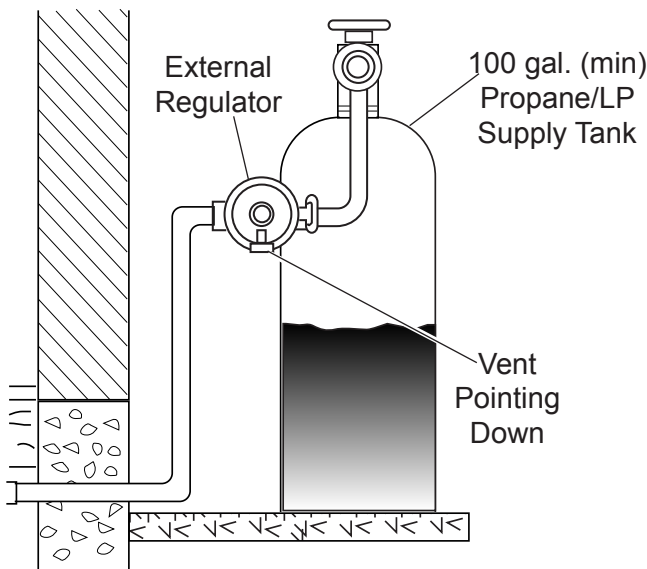

Figure 27 - External Regulator with Vent Pointing Down (Propane/LP Only)

CAUTION

Use only new black iron or steel pipe. Internally tinned copper or copper tubing can be used per National Fuel Code, section 2.6.3, providing gas meets hydrogen sulfide limits, and where permitted by local codes. Gas piping system must be sized to provide minimum inlet pressure (listed on data plate) at the maximum flow rate (BTU/hr). Undue pressure loss will occur if the pipe is too small.

When using copper or flex connectors use only fittings approved for gas connections. The gas control inlet is $\frac{3}{8}$ " NPT.

STOVE INSTALLATION

WARNING

Only persons licensed to work with gas piping may make the necessary gas connections to this appliance.

CAUTION

A manual shutoff valve must be installed upstream of the appliance. Union tee and plugged $\frac{1}{8}$ " NPT pressure tapping point should be installed upstream of the appliance. See *Figure 28*.

NOTE : The gas line connection may be made using $\frac{1}{2}$ " rigid tubing or an approved flex connector. Since some municipalities have additional local codes it is always best to consult your local authorities and the current edition of the National Fuel Gas Code ANSI.Z223.1, NFPA54. In Canada CAN/CGA-B149 (1 or 2) Installation Code.

A listed manual shutoff valve must be installed upstream of the appliance. Union tee and plugged $\frac{1}{8}$ " NPT pressure tapping point should be installed upstream of the appliance. See *Figure 28*.

IMPORTANT: Install main gas valve (equipment shutoff valve) in an accessible location. The main gas valve is for turning on or shutting off the gas to the stove.

Check your building codes for any special requirements for locating equipment shutoff valve to stoves.

Apply pipe joint sealant lightly to make threads. This will prevent excess sealant from going into pipe. Excess sealant in pipe could result in clogged burner system valves.

CAUTION

Use pipe joint sealant that is resistant to liquid petroleum (LP) gas.

We recommend that you install a sediment trap/drip leg in supply line as shown in *Figure 28*. Locate sediment trap/drip leg where it is within reach for cleaning. Install in piping system between fuel supply and burner system. Locate sediment trap/drip leg where trapped matter is not likely to freeze. A sediment trap traps moisture and contaminants. This keeps them from going into the burner system gas controls. If sediment trap/drip leg is not installed or is installed wrong, burner system may not run properly.

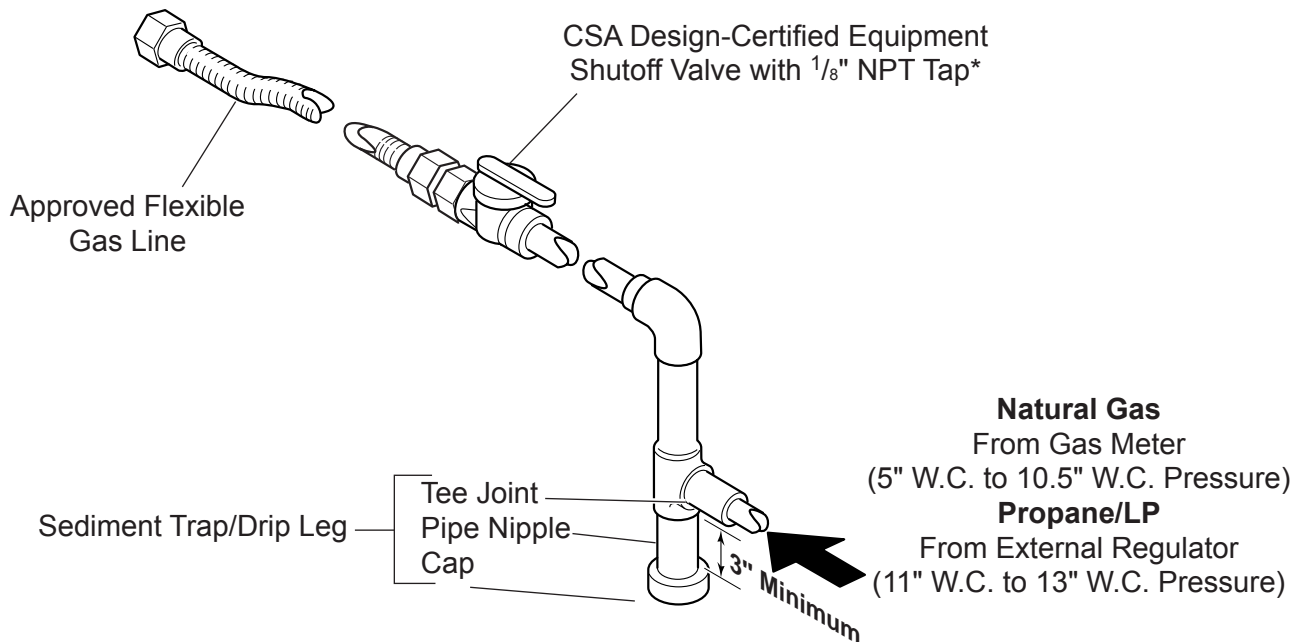

Figure 28 - Gas Connection

CHECKING GAS PRESSURE AND INSTALLING LOUVERS

1. Check gas type. The gas supply must be the same as stated on the appliance's rating decal. If the gas supply is different from the fireplace, STOP! Do not install the appliance. Contact your dealer immediately.
2. To ease installation, a 30" (mm) flex line with manual shut-off valve has been provided with on this appliance. Install and attach 1/2" gas line onto shut-off valve.
3. After completing gas line connection, purge air from gas line and test all gas joints from the gas meter to the fireplace for leaks. Use a soap and water solution or a gas sniffer.
4. To adjust flame height, turn HI/LO knob to HI to get maximum pressure to burner. Turn HI/LO knob to LO to get minimum pressure.
5. To check gas pressures at valve, turn captured screw counter clockwise 2 or 3 turns and then place tubing to pressure gauge over test point. Turn unit to high. See Figure 29. After taking pressure reading, be sure and turn captured screw clockwise firmly to reseal. Do not over torque. Check test points for gas leaks with a soap and water solution.

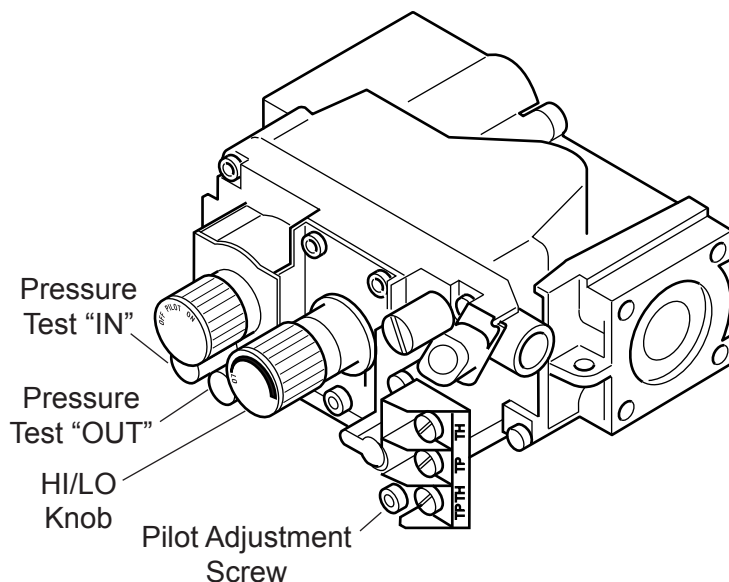

Figure 29 - Gas Pressure Check at Gas Valve

WARNING

Do not use open flame to check for gas leaks.

INSTALLING LOUVERS

Attach the top louver unit (two louvers and two louver brackets) to stove with four (4) screws provided — two (2) on each side. See Figure 30. Repeat for bottom louver unit.

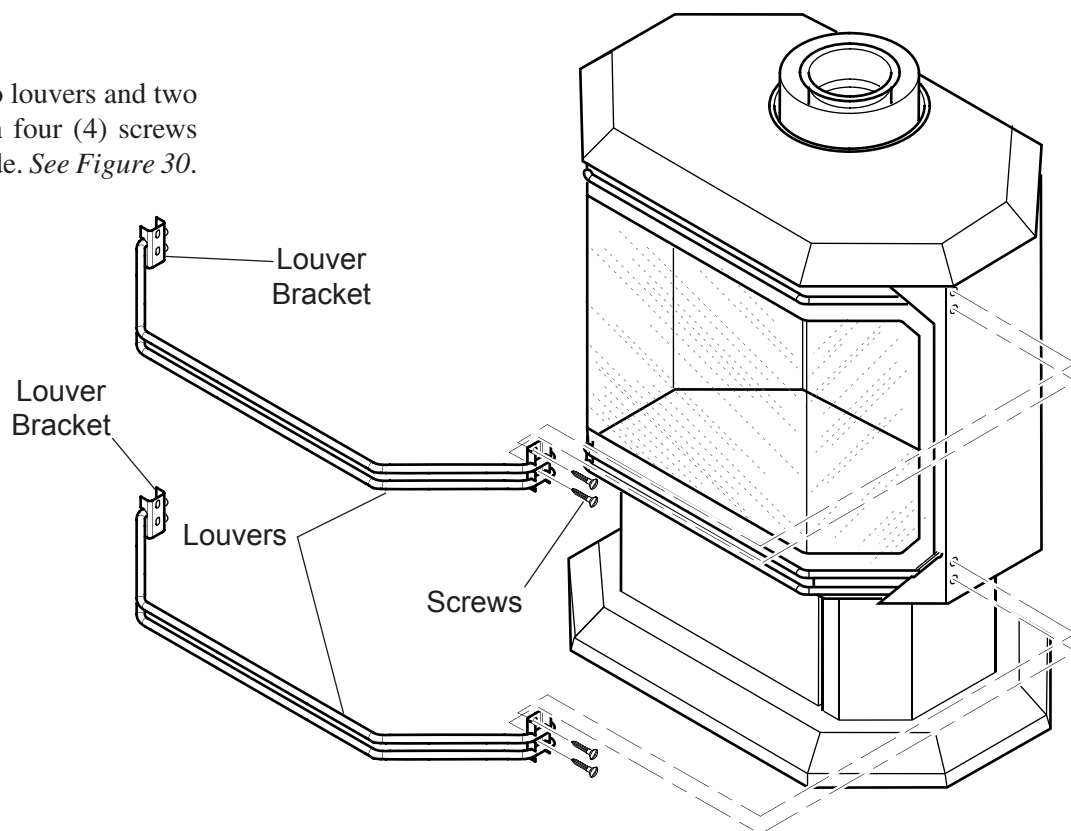

Figure 30 - Installing Louvers

ELECTRICAL INSTALLATION

ELECTRICAL WIRING

This stove will work without any electrical supply. Electricity is only needed to operate blower.

NOTE: If installed in mobile home, stove must be bolted securely to floor.

WARNING

Electrical connections should only be performed by a qualified, licensed electrician. Main power must be off when connecting to main electrical power supply or performing service. All wiring shall be in compliance with all local, city, and state codes. The appliance, when installed, must be electrically grounded in accordance with local codes, or in the absence of local codes, with the *National Electrical Code ANSI/ NFPA 70 (latest edition)* and *Canadian Electrical Code, CSA C22.1*.

CAUTION

Label all wires before disconnecting when servicing controls. Wiring errors can cause improper and dangerous operation.

Verify proper operation after servicing.

REMOTE WALL MOUNTED SWITCH

A remote wall switch and up to fifteen (15) feet of 18 Ga. wire may be used with this appliance. Attach the wall switch in a junction box at the desired location on the wall. See Figure 31. Do not extend beyond the wall switch wire length provided.

NOTE: Extended lengths of wire may cause the fireplace not to function properly. Longer length of wire is permitted if the wire is made out of larger gauge (diameter) wire. Always check with local code.

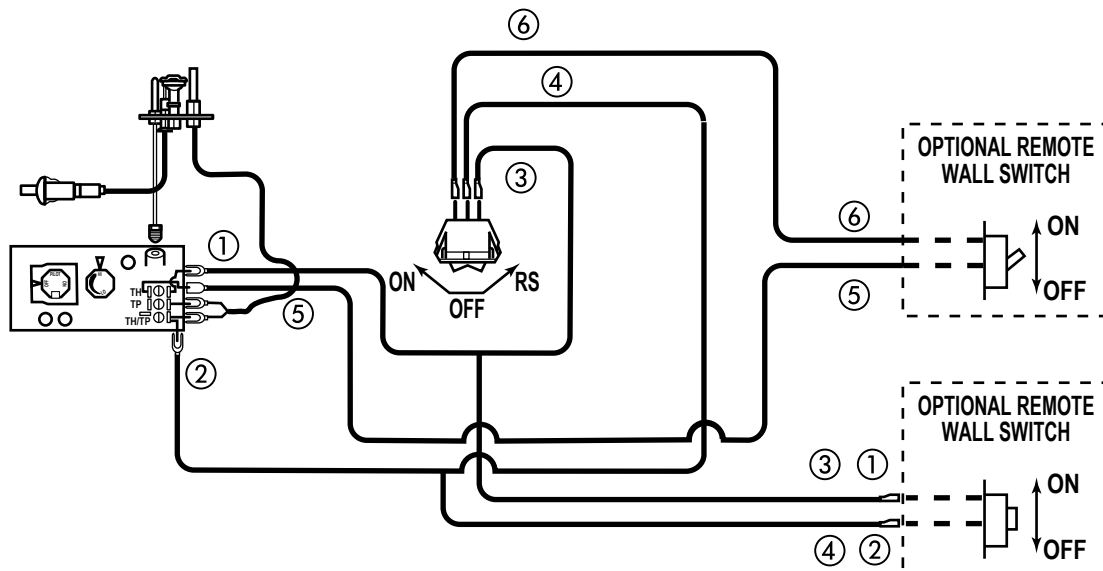

Figure 31 - Wiring Diagram for Wall Switch

Before you begin — This unit is supplied with six ceramic fiber logs. Do not handle these logs with your bare hands. **Always wear gloves to prevent skin irritation from ceramic fibers.** After handling the logs, wash your hands gently with soap and water to remove any traces of fibers.

WARNING

The positioning of the logs is critical to the safe and clean operation of this heater. Sooting and other problems may result if the logs are not properly and firmly positioned in the appliance. Never add additional logs or embellishments such as pine cones or vermiculite to the heater. Only use the logs supplied with the unit.

Failure to position the parts in accordance with diagrams below or to use only parts specifically approved for this heater may result in property damage or personal injury.

INSTALLING LOGS AND ROCK WOOL (EMBER MATERIAL) IN FIREBOX

1. Carefully remove logs from wrapping.
2. Open front door of firebox.
3. Place rear log against back of firebox. *See Figure 32.*
4. Place left base log on two pins against left side of firebox. *See Figure 33.*

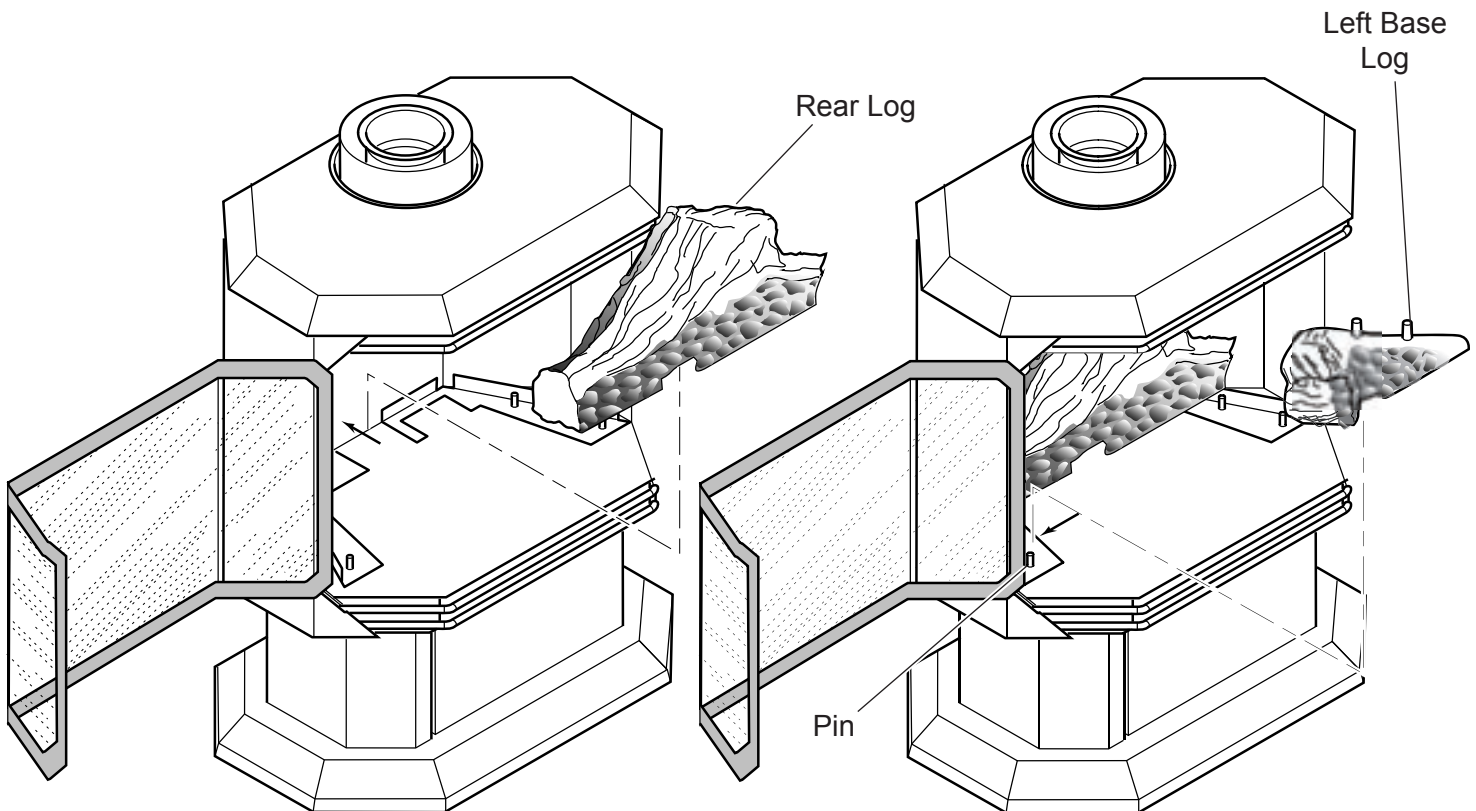

**Figure 32 -
Installing Rear Log**

**Figure 33 - Installing Left
Base Log**

Continued on next page

LOG PLACEMENT

5. Place right base log on two pins against right side of firebox. *See Figure 34.*
6. Place top left log on left base log. Line up the hole in the bottom of the top log with the locating pins on the bottom log. *See Figure 35.*

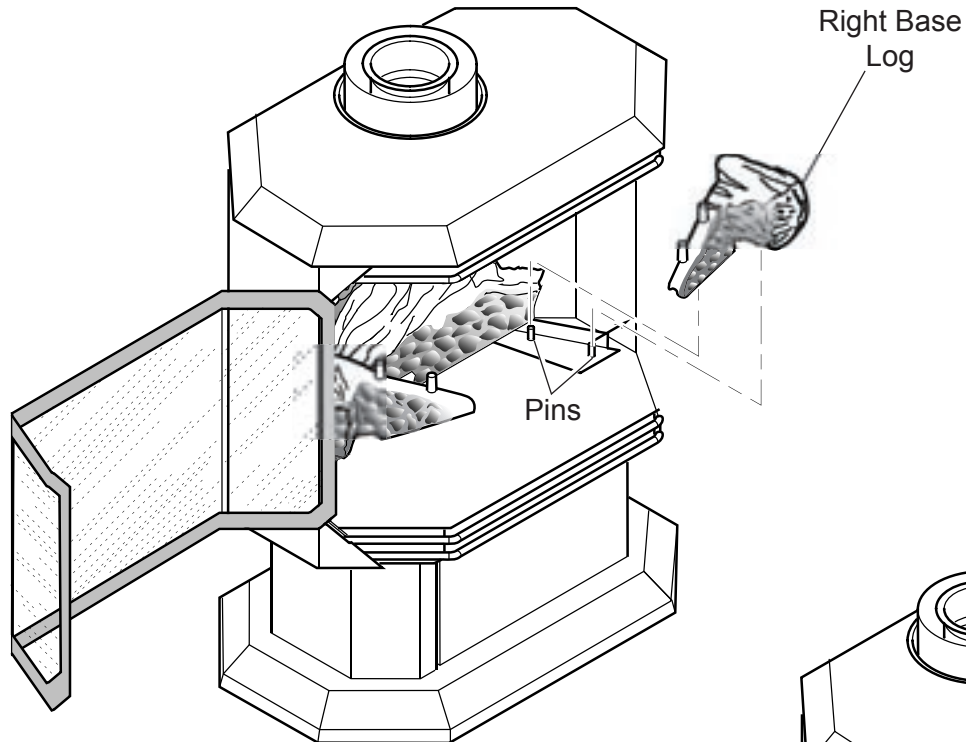

Figure 34 - Installing Right Base Log

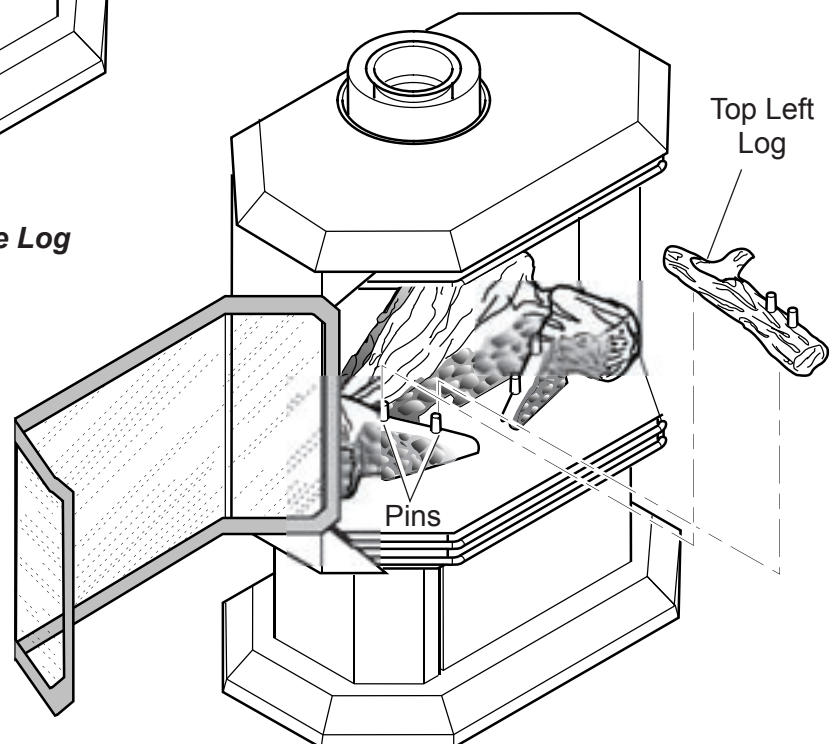

Figure 35 - Installing Top Left Log

7. Place top right log on right base log. Line up the holes in the bottom of the top log with the locating pins on the bottom log. *See Figure 36.*
8. Place top center log on top left log pins sand angle to burner. *See Figure 37.*

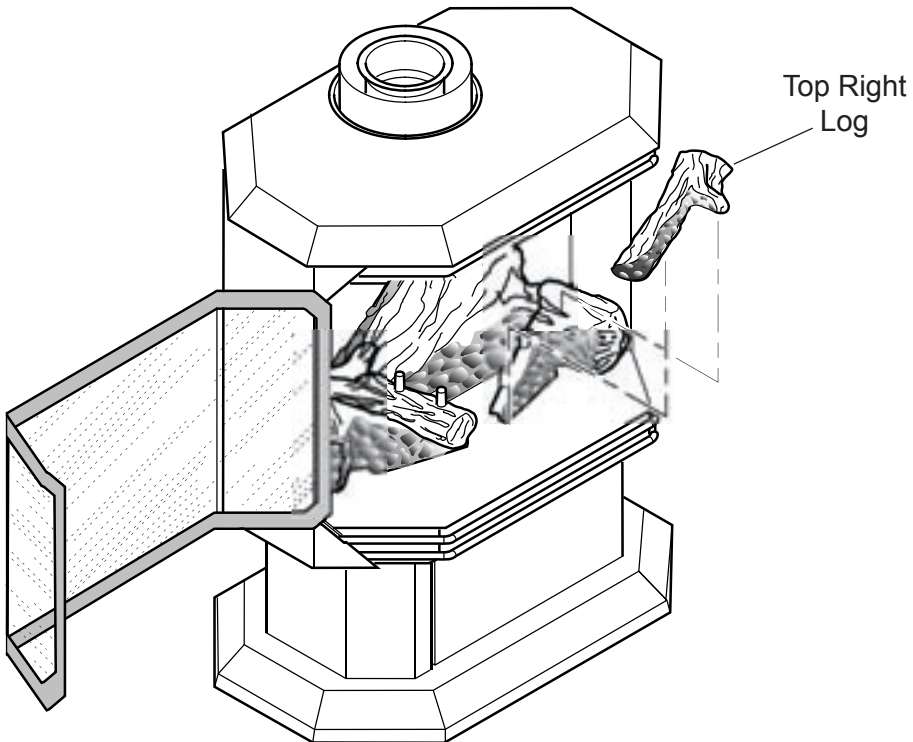

Figure 36 - Installing Top Right Log

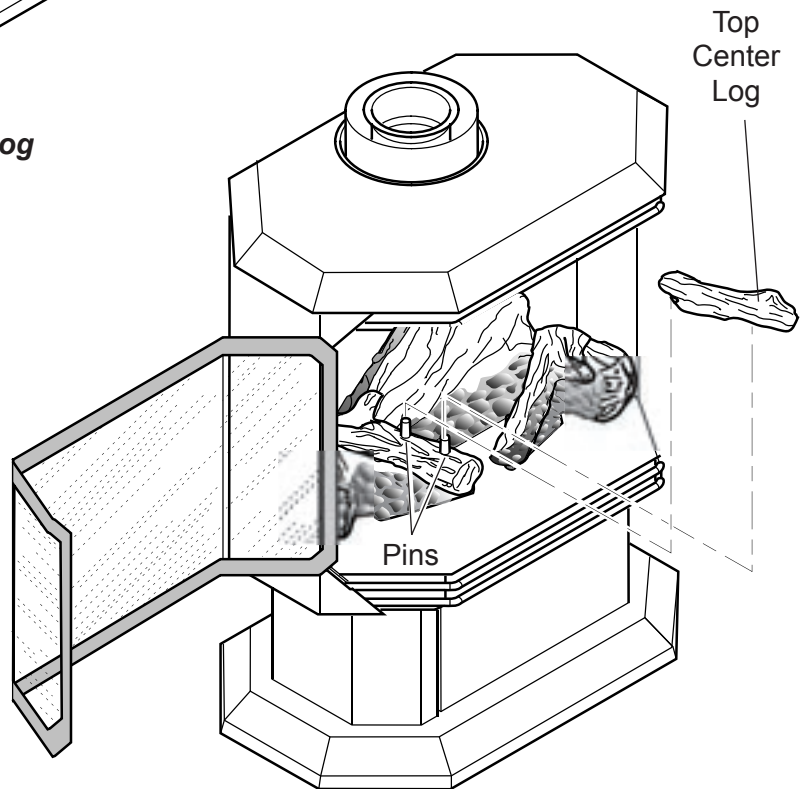

Figure 37 - Installing Top Center Log

Continued on page 29

LOG PLACEMENT

9. Break up rock wool (ember material) into dime-sized pieces. Place evenly across burner surface and mesh of grate. See *Figures 38 and 39*. Do not exceed 1" depth of coverage.

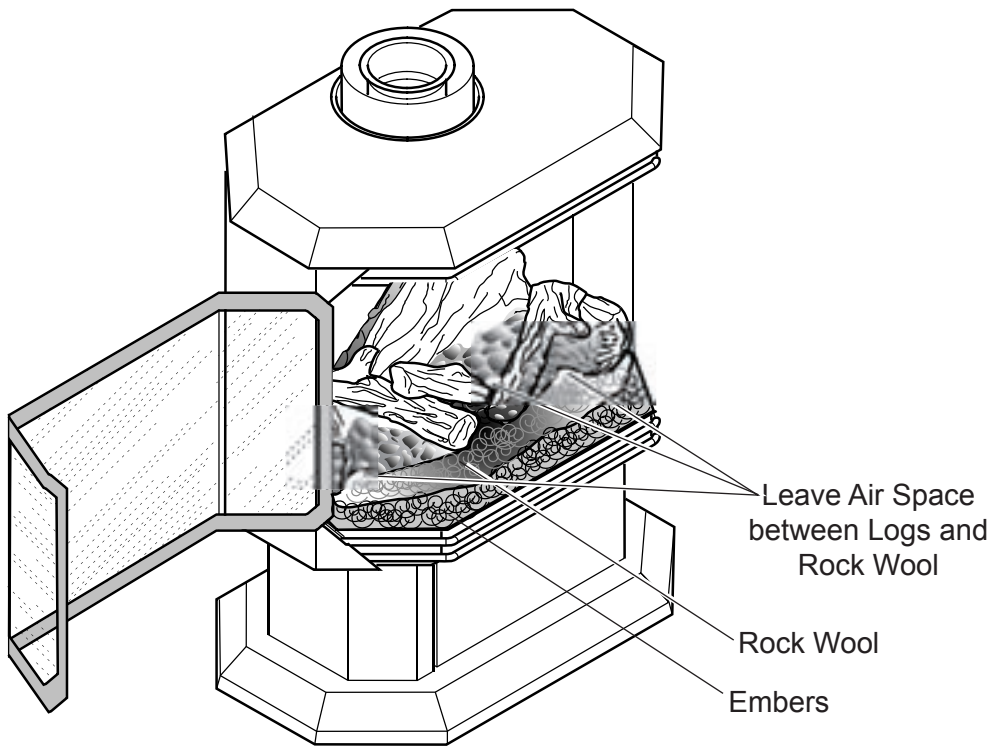

Figure 38 - Installing Rock Wool

FOR YOUR SAFETY READ BEFORE LIGHTING**WARNING**

If you do not follow these instructions exactly, a fire or explosion may result causing property damage, personal injury or loss of life.

- A. This appliance is equipped with a pilot which must be lit with built-in battery ignitor while following these instructions exactly.
- B. BEFORE OPERATING smell all around the appliance area for gas. Be sure to smell next to the floor because some gas is heavier than air and will settle on the floor.

WHAT TO DO IF YOU SMELL GAS:

- Turn off all gas to the appliance.
 - Open windows.
 - Do not attempt to light any appliance.
 - Do not touch any electric switch; do not use any phone in your building.
 - Immediately call your gas supplier from a neighbor's phone. Follow the gas supplier's instructions.
 - If you cannot reach your gas supplier, call the fire department.
- C. Use only your hand to push in, or turn the gas control knob. Never use tools. If the knob will not push in or turn by hand, don't try to repair it. Call a qualified service technician. Force or attempted repair may result in a fire or explosion.
 - D. Do not use this appliance if any part of it has been under water. Immediately call a qualified service technician to inspect the appliance and to replace any part of the control system and any gas control that has been under water.

LIGHTING PILOT FOR THE FIRST TIME**INITIAL LIGHTING**

Purge air from the supply line as follows:

- Open main shutoff valve.
- Unscrew main pressure test point.
- Leave inlet test screw open until gas comes in.
- When gas is flowing, tighten inlet screw immediately.

WARNING

Never use an open flame to check for gas leak.

LEAK TESTING

1. Follow the pipe from the gas supply line connection to the gas valve. Check connection for leaks with soap and water mixture.
2. Next check for gas leaks at the burner thread inlet with soap and water mixture.
3. Check the pilot for gas leaks with soap and water mixture.

Continued on next page

LIGHTING PILOT FOR THE FIRST TIME

APPROVED LEAK TESTING METHOD

You may check for gas leaks with the following methods only:

- Soap and water solution
- An approved leak testing spray
- Electronic sniffer

DANGER

Never check for gas leak with open flame!

WARNING

If using a soap and water solution to test for leaks, **DO NOT** spray solution onto control body.

NOTE: Remove any excessive pipe compound from the connections. Excessive pipe compound can set off electronic sniffers.

Check for gas leaks in each of the following locations:

- Pipe from the gas supply line connection to the gas valve
- Burner thread inlet
- Pilot
- Each joint or connection
- Field made joints
- Factory made joints
- All joints on valve and control body

LIGHTING PILOT

WARNING

The control has an interlock device that does not allow the lighting of the stove up to the moment the safety device of the flame has not interrupted the gas flow. After that period of time (when the magnet is closed), it is possible to start the lighting operation.

The gas control knob is designed to be operated by hand. **DO NOT** use any tools during this operation. Damaged knobs may result in serious injury.

1. Depress and turn knob counterclockwise  to pilot position.
2. Depress fully and hold pilot gas knob. The electronic ignitor will automatically ignite the pilot. Keep knob fully depressed for a few seconds. Release and check that pilot continues to burn.

If the pilot does not stay lit, repeat steps 1 and 2.

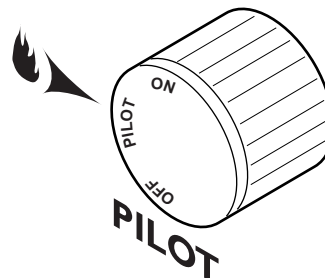

Figure 40 - Pilot Position

LIGHTING BURNER

MAIN BURNER SWITCH

The “ON/OFF/RS” switch for the main burner can be behind the pedestal door of the stove. This switch allows you to turn on and to turn off the main burner without using the gas valve knob. Make sure the button is in the “ON” position to light the main burner. *See Figure 41.*

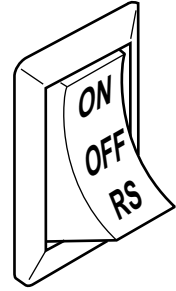



Figure 41 - On/Off/RS Switch

LIGHTING THE BURNER

Depress and turn the knob counterclockwise  to the “ON” position. *See Figure 42.* It will take less than four (4) seconds for the burner to ignite.

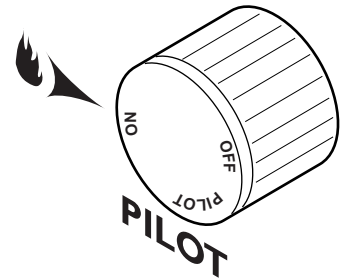

Figure 42 - On Position

PILOT POSITION

Depress and turn knob to pilot position to keep burner off while maintaining the pilot light. *See Figure 43.*

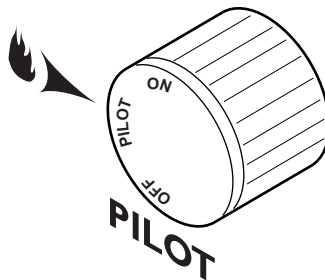

Figure 43 - Pilot Position

TO TURN OFF GAS

Depress and turn knob clockwise  to “OFF” position. *See Figure 44.*

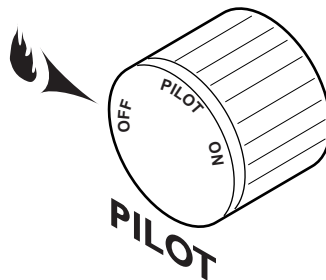

Figure 44 - Off Position

CLEANING AND MAINTENANCE

Make sure the gas valve knob is in the “OFF” position. Wait at least five (5) minutes before starting maintenance.

VENTING SYSTEM

A qualified agency should examine the venting system annually.

CLEANING GLASS

Clean the ceramic glass periodically. Condensation will sometimes form on the glass during a cold startup. This is normal for all gas fireplaces and stoves. This condensation often attracts dust and lint to the surface of the glass. The initial paint curing of the appliance can also leave a slight film on the glass. This is a temporary problem.

You should clean the glass after the first two weeks of use. After that, you should clean the glass no more than two or three times a season. Use a mild glass cleaner to clean the door. Do not use abrasive cleaners. They will damage the glass surface.

PILOT AND BURNER FLAMES

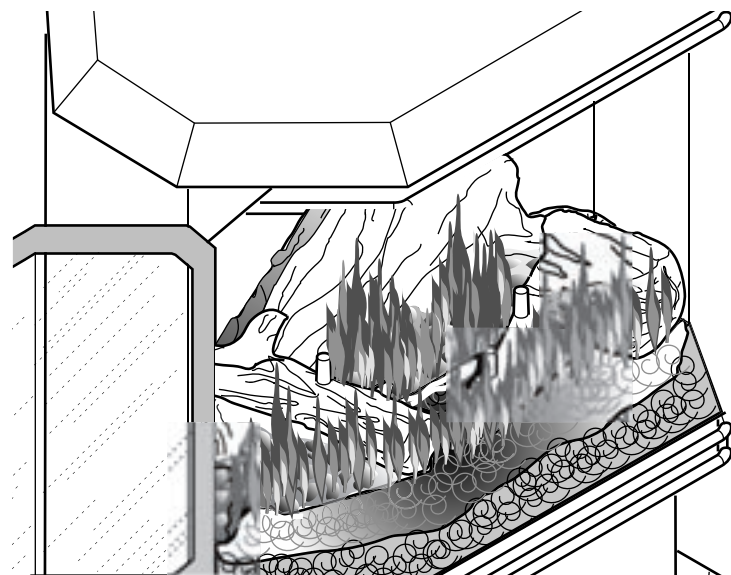

Figure 45 - Typical Burner Flame

FIREBOX CLEANING

1. Carefully remove log set, and embers from combustion chamber.
2. Vacuum burner compartment thoroughly.
3. Vacuum any dust off logs.
4. Remove any lint from main burner and pilot.
5. Carefully replace log set, and embers in their correct positions. *See pages 25 through 28.*
6. Replace door (if it has been removed).
7. Relight pilot. *See page 30.*
8. Turn on main burner.

CAUTION

Let glass cool before cleaning. Do not clean glass when it is hot. Damage could occur.

Visually check pilot and burner flames periodically. *See Figure 45* for typical burner flame. *See Figure 46* for typical pilot flame.

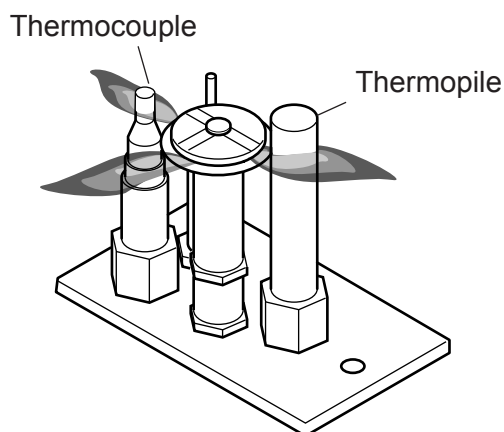

Figure 46 - Typical Pilot Flame

WARNING

Make sure clearances to combustibles leave room for maintenance and service.

WARNING

Carefully reassemble and reseal stove properly after any cleaning or servicing.

AIR SHUTTER ADJUSTMENT (NATURAL GAS ONLY)

ADJUSTING THE AIR SHUTTER

The venturi of the burner is equipped with an air shutter. The opening of the venturi has been set at $\frac{1}{4}$ " for Natural Gas and fully open for Propane installation at sea level. Natural Gas Models may be adjusted for high altitude as follows:

- To increase air mixture, push up the adjustment rod located beneath the stove. This opens the shutter more and will stop or minimize sooting. *See Figure 47.*
- To decrease air mixture, pull down the adjustment rod located beneath the stove. This closes the shutter. Flames will be more yellow. *See Figure 48.*

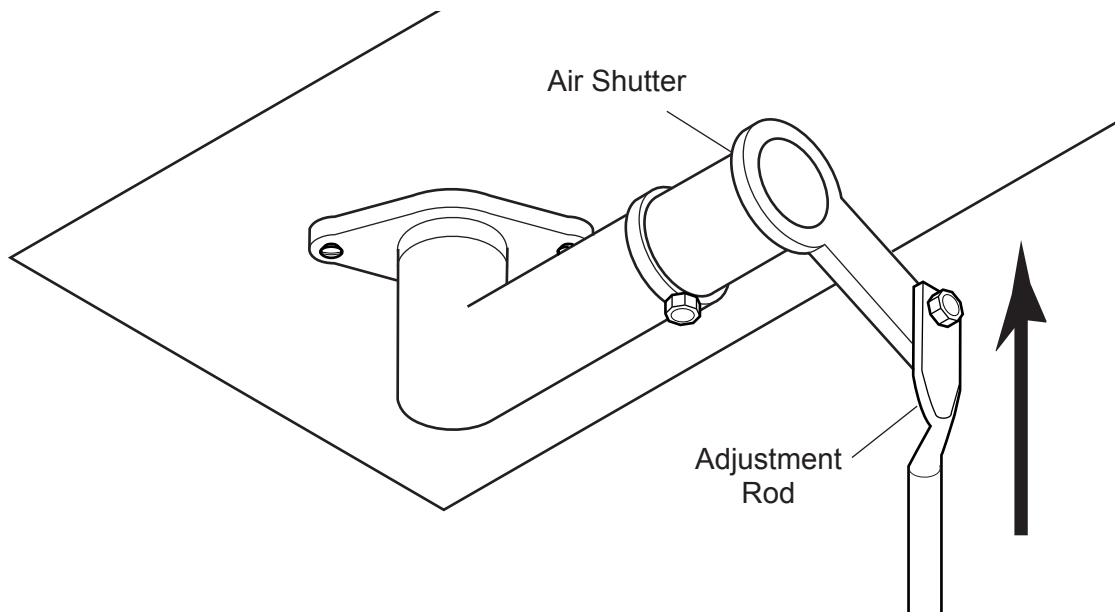

Figure 47 - Push Adjustment Rod Up to Open Air Shutter

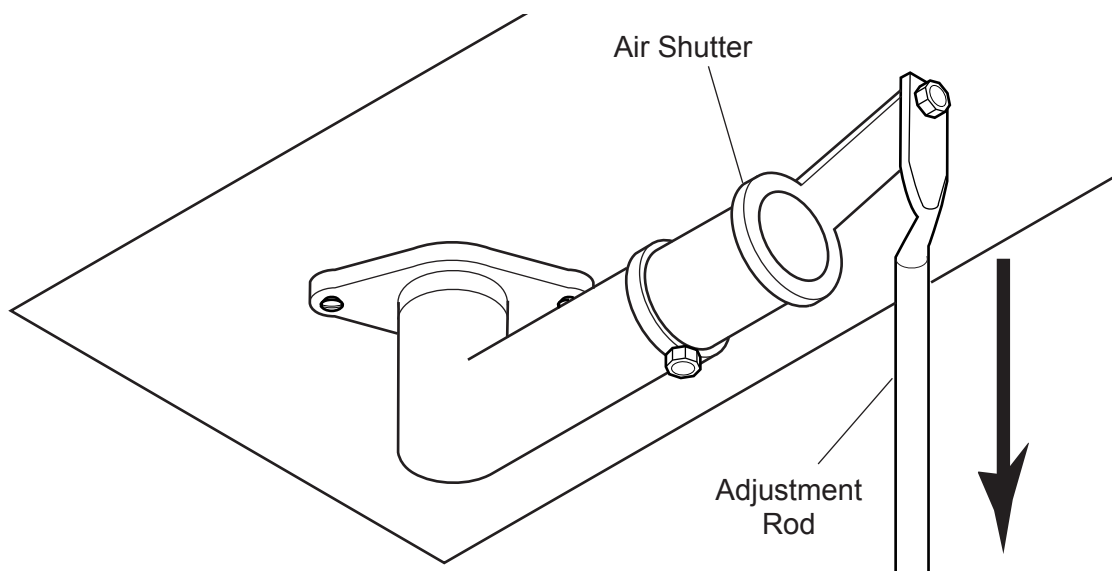

Figure 48 - Pull Adjustment Rod Down to Close Air Shutter

GLASS REPLACEMENT

CAUTION

Always use gloves when handling broken glass.

WARNING

Make sure the glass panel edges do not touch any metal parts during thermal expansion.

1. Put on gloves. Remove door from hinges by lifting the door up. *See Figure 49.*
2. Remove the $\frac{7}{8}$ " rope from around glass frame. *See Figure 49.*
3. Using a $\frac{5}{16}$ " socket, remove hex nuts from glass retaining brackets. Remove retaining brackets. *See Figure 50.*
4. Carefully remove broken glass.
5. Wrap new glass pane(s) with $\frac{3}{4}$ " gasket. Make sure you have $\frac{1}{4}$ " overlap on each side.
6. Place new glass in frame. For three-piece glass style frame, slide new glass into the 45° aluminum post (not shown).
7. Fasten retaining brackets back into place with $\frac{5}{16}$ " nuts.
8. Replace $\frac{7}{8}$ " rope. Make sure the joint is at the bottom and there is no gap.
9. Slide door back down the hinges. *See Figure 49.*

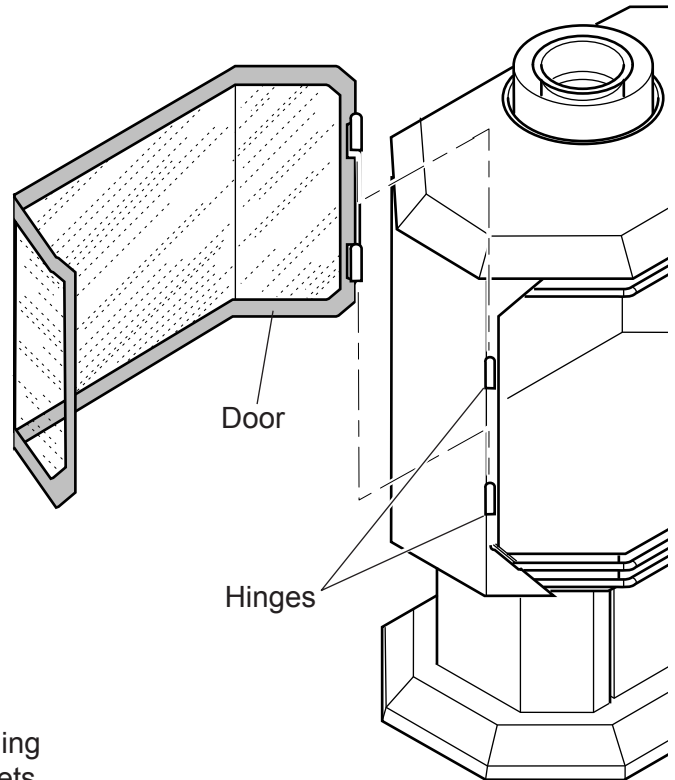

Figure 49 - Removing Door from Hinges

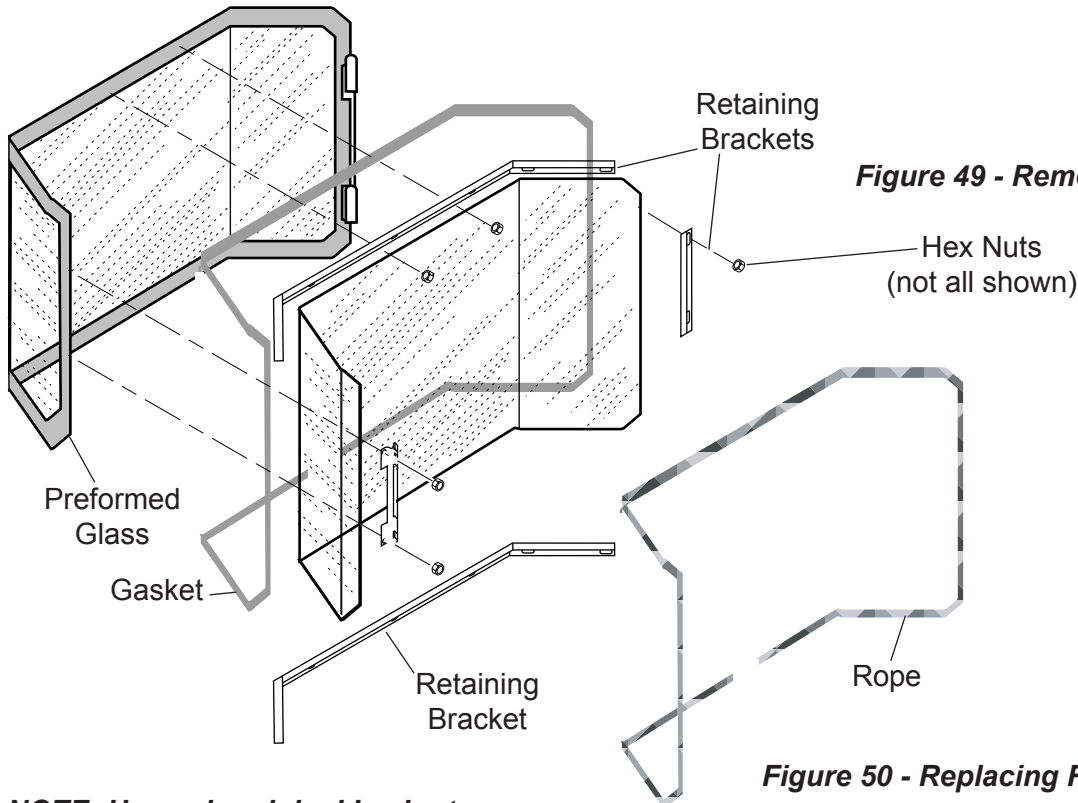
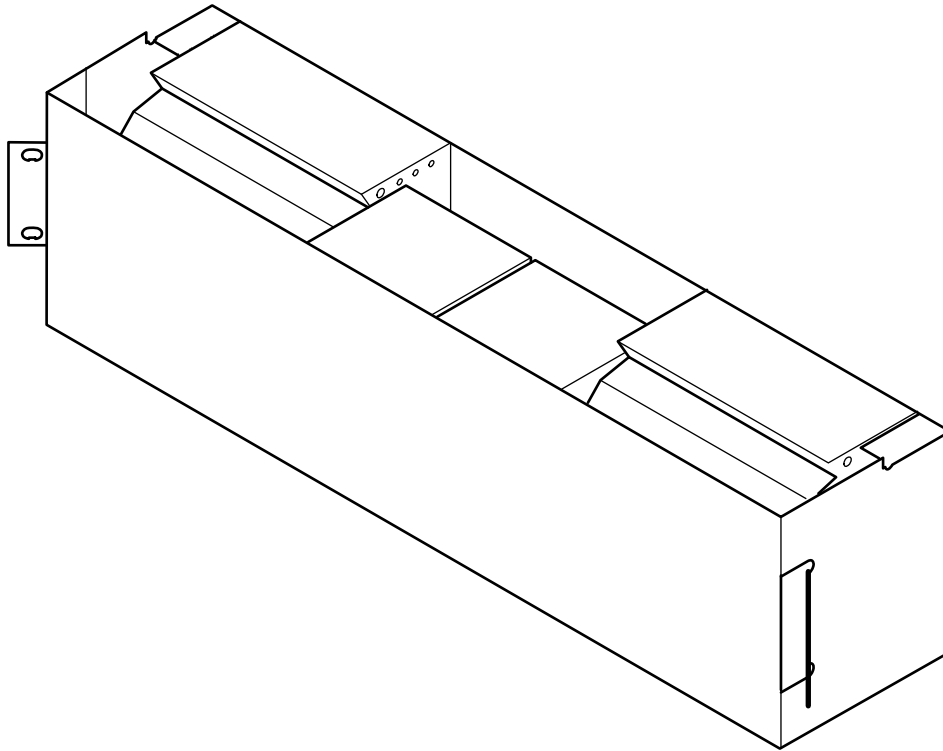

Figure 50 - Replacing Formed Glass

NOTE: Use only original Lexington Forge replacement parts.

BLOWER



WIRING DIAGRAM FOR BLOWER

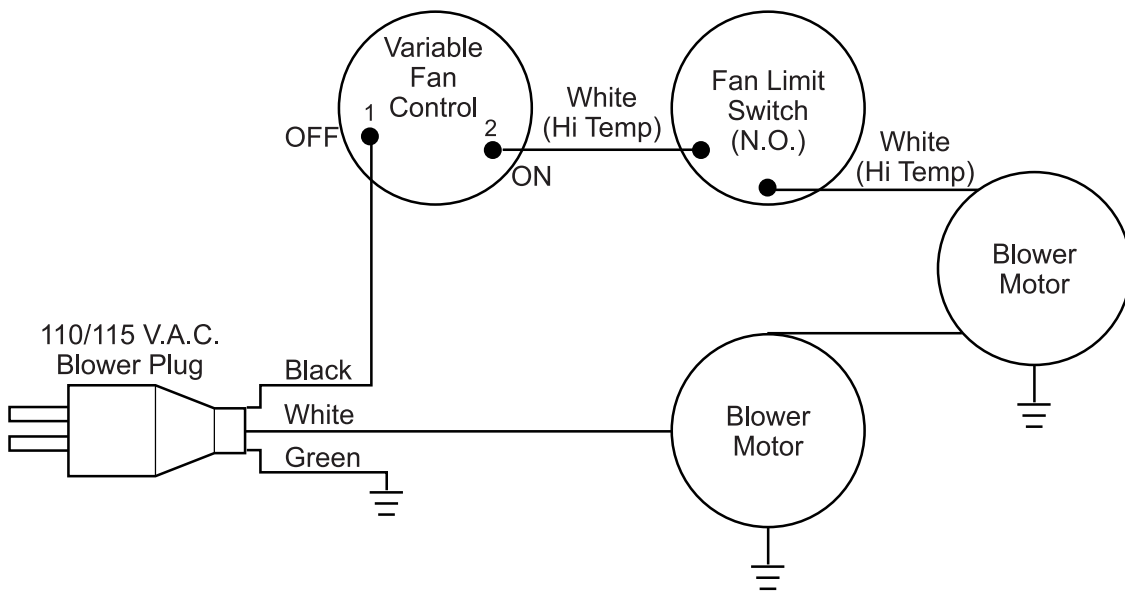

REPLACEMENT PARTS

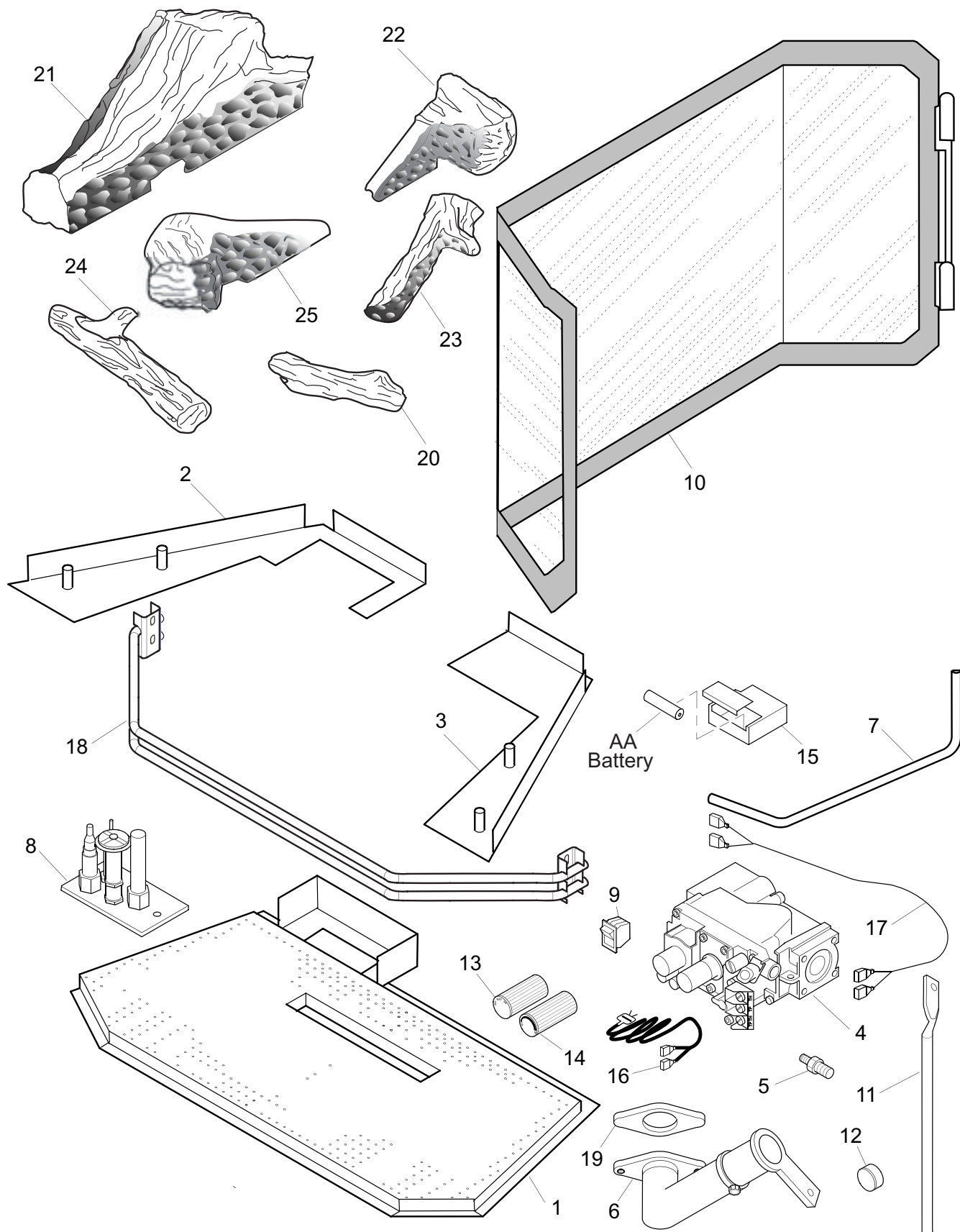

REPLACEMENT PARTS

REPLACEMENT PARTS ARE AVAILABLE THROUGH YOUR RETAILER

Item	Description	QTY	SS38DV[B,G]F(N,P)		SS38DV[B,G](N,P)	
			Natural	Propane	Natural	Propane
1	Burner Assembly	1	46D0177	46D0177	46D0177	46D0177
2	Left Log Support Bracket	1	46D0251K	46D0251K	46D0251K	46D0251K
3	Right Log Support Bracket	1	46D0252K	46D0252K	46D0252K	46D0252K
4	SIT 820 Nova Valve	1	37D0117	37D0118	37D0117	37D0118
5	Injector	1	57D0209	57D0680	57D0209	57D0680
6	Venturi	1	45D0600	45D0600	45D0600	45D0600
7	Tube Valve/Burner	1	45D0085K	45D0085K	45D0085K	45D0085K
8	Pilot Assembly	1	37D0018	37D0019	37D0018	37D0019
9	Rocker Switch	1	41D0048	41D0048	41D0048	41D0048
10	Formed Glass	1	46D0159	46D0159	46D0159	46D0159s
11	Air Shutter Rod	1	46D0211	46D0211	46D0211	46D0211
12	Air Shutter Knob	1	45D0237	45D0237	45D0237	45D0237
13	Knob Extension HI/LO	1	43D0095	43D0095	43D0095	43D0095
14	Knob Extension ON/OFF	1	43D0094	43D0094	43D0094	43D0094
15	Ignitor Battery Module	1	45D0077	45D0077	45D0077	45D0077
16	Ignitor Wire Harness	1	44D0500	44D0500	44D0500	44D0500
17	ON/OFF Wire Harness	1	45D0565	45D0565	45D0565	45D0565
18	Louvers	1	46D0704	46D0704	46D0704	46D0704
19	Burner Gasket Set	1	45D0027	45D0027	45D0027	45D0027
Logs						
20	Center Log	1	46D0222	46D0222	46D0222	46D0222
21	Rear Log	1	46D0217	46D0217	46D0217	46D0217
22	Right Bottom Log	1	46D0219	46D0219	46D0219	46D0219
23	Right Top Log	1	46D0221	46D0221	46D0221	46D0221
24	Left Top Log	1	46D0220	46D0220	46D0220	46D0220
25	Left Bottom Log	1	46D0218	46D0218	46D0218	46D0218
Available Not Shown						
	Vertical Restrictor	1	45D0551	45D0551	45D0551	45D0551
	Ceramic Glass Center	1			46D0160	46D0160
	Ceramic Glass Side	2			46D0158	46D0158
	Engine Gasket Set	1	45D0033	45D0033	45D0033	45D0033
Accessories						
	Propane Gas Conversion Kit	1	SS38CKP		SS38CKP	
	Natural Gas Conversion Kit	1		SS38CKN		SS38CKN

WARNING

Failure to position the parts in accordance with these diagrams or failure to use only parts specifically approved with this appliance may result in property damage or personal injury.

TROUBLESHOOTING

WARNING

Turn appliance OFF and allow to cool before servicing. Only a qualified service person should service and repair the heater.

Note: All troubleshooting items are listed in order of operation.

OBSERVED PROBLEM	POSSIBLE CAUSE	REMEDY
Spark ignitor will not light the pilot after repeated pressing of spark ignitor.	<ol style="list-style-type: none"> 1. Battery needs replacing 2. Defective ignitor 3. Misaligned spark electrode 4. Bad wire. 	<ol style="list-style-type: none"> 1. Replace battery 2. Check connections to ignitor. Replace ignitor if ignitor connections are good, but there is no spark. 3. Check for spark arcing from the electrode to pilot. Adjust by loosening screws on pilot base. Adjust and retighten. 4. Replace with new wire.
Pilot will not stay lit.	<ol style="list-style-type: none"> 1. Defective thermocouple. Loose thermocouple 2. Air in gas line 3. No gas 	<ol style="list-style-type: none"> 1. A. Check for proper connection of thermocouple to rear of valve. B. Check thermocouple output. 2. Bleed line. Contact dealer 3. Check shutoff valve and gas supply (LPG tank)
Burner will not light when valve and burner switch are both on.	<ol style="list-style-type: none"> 1. Defective switch 2. Defective thermopile 3. Thermostat set too low/defective 	<ol style="list-style-type: none"> 1. Check switch connections. Jump wires at switch. 2. A. Check thermopile output. B. Check connections to valve. Contact dealer. 3. Turn up thermostat to start unit. Check thermostat connections.
Glass fogs up	<ol style="list-style-type: none"> 1. Normal condition 	<ol style="list-style-type: none"> 1. Allow appliance to warm up. Glass will clear. Additives in the gas may dirty glass. Clean glass when cool.
Blue flames	<ol style="list-style-type: none"> 1. Normal during start up 	<ol style="list-style-type: none"> 1. Flames will yellow as appliance heats up.
Sooting	<ol style="list-style-type: none"> 1. Flame impingement 	<ol style="list-style-type: none"> 1. Check log position. Open shutters to increase primary air.

INSTALLATION RECORDS

THE FOLLOWING INFORMATION MUST BE RECORDED BY THE INSTALLER FOR WARRANTY PURPOSES AND FUTURE REFERENCE.

LEXINGTON FORGE

Model: _____

<p>Name of Owner:</p> <p>Address:</p> <p>Phone:</p>	<p>Name of Installer:</p> <p>Address:</p> <p>Phone:</p>
<p>Name of Dealer:</p> <p>Address:</p> <p>Phone:</p>	

**Manufactured by
LEXINGTON FORGE
149 Cleveland Drive
Paris, Kentucky 40361, U.S.A.**

MASSACHUSETTS RESIDENTS ONLY: PLEASE READ AND FOLLOW THESE SPECIAL REQUIREMENTS

NOTE REGARDING VENTED PRODUCTS

This product must be installed by a licensed plumber or gas fitter when installed within the Commonwealth of Massachusetts.

Any residence with a direct vent product must have a CO detector installed in the residence.

Installation of the fireplace or vented gas log in the State of Massachusetts requires the damper to be permanently removed or welded in the fully open position.

In addition, a naturally vented gas log may not be installed in a bedroom or bathroom in the State of Massachusetts.

Flex line installation must not exceed 36 inches and must have a T shutoff valve.

NOTE REGARDING VENT FREE PRODUCTS

This product must be installed by a licensed plumber or gas fitter when installed within the Commonwealth of Massachusetts.

In addition, vent free products may not be installed in a bedroom or bathroom regardless of size or type in the State of Massachusetts.

Flex line installation must not exceed 36 inches and must have a T shutoff valve.

CARBON MONOXIDE DETECTOR REQUIREMENTS

(2) Revise 10.8.3 by adding the following additional requirements:

(a) For all side wall horizontally vented gas fueled equipment installed in every dwelling, building or structure used in whole or in part for residential purposes, including those owned or operated by the Commonwealth and where the side wall exhaust vent termination is less than seven (7) feet above finished grade in the area of the venting, including but not limited to decks and porches, the following requirements shall be satisfied:

1. **INSTALLATION OF CARBON MONOXIDE DETECTORS.** At the time of installation of the side wall horizontal vented gas fueled equipment, the installing plumber or gasfitter shall observe that a hard wired carbon monoxide detector with an alarm and battery back-up is installed on the floor level where the gas equipment is to be installed. In addition, the installing plumber or gasfitter shall observe that a battery operated or hard wired carbon monoxide detector with an alarm is installed on each additional level of the dwelling, building or structure served by the side wall horizontal vented gas fueled equipment. It shall be the responsibility of the property owner to secure the services of qualified licensed professionals for the installation of hard wired carbon monoxide detectors
 - a. In the event that the side wall horizontally vented gas fueled equipment is installed in a crawl space or an attic, the hard wired carbon monoxide detector with alarm and battery back-up may be installed on the next adjacent floor level.
 - b. In the event that the requirements of this subdivision can not be met at the time of completion of installation, the owner shall have a period of thirty (30) days to comply with the above requirements; provided, however, that during said thirty (30) day period, a battery operated carbon monoxide detector with an alarm shall be installed.
-

SPECIAL REQUIREMENTS CONTINUED

2. APPROVED CARBON MONOXIDE DETECTORS. Each carbon monoxide detector as required in accordance with the above provisions shall comply with NFPA 720 and be ANSI/UL 2034 listed and IAS certified.
 3. SIGNAGE. A metal or plastic identification plate shall be permanently mounted to the exterior of the building at a minimum height of eight (8) feet above grade directly in line with the exhaust vent terminal for the horizontally vented gas fueled heating appliance or equipment. The sign shall read, in print size no less than one-half (1/2) inch in size, **“GAS VENT DIRECTLY BELOW. KEEP CLEAR OF ALL OBSTRUCTIONS.”**
 4. INSPECTION. The state or local gas inspector of the side wall horizontally vented gas fueled equipment shall not approve the installation unless, upon inspection, the inspector observes carbon monoxide detectors and signage installed in accordance with the provisions of 248 CMR 5.08(2)(a)1 through 4.
- (b) EXEMPTIONS: The following equipment is exempt from 248 CMR 5.08(2)(a)1 through 4:
1. The equipment listed in Chapter 10 entitled “Equipment Not Required To Be Vented” in the most current edition of NFPA 54 as adopted by the Board; and
 2. Product Approved side wall horizontally vented gas fueled equipment installed in a room or structure separate from the dwelling, building or structure used in whole or in part for residential purposes.
- (c) MANUFACTURER REQUIREMENTS - GAS EQUIPMENT VENTING SYSTEM PROVIDED. When the manufacturer of Product Approved side wall horizontally vented gas equipment provides a venting system design or venting system components with the equipment, the instructions provided by the manufacturer for installation of the equipment and the venting system shall include:
1. Detailed instructions for the installation of the venting system design or the venting system components; and
 2. A complete parts list for the venting system design or venting system.
- (d) MANUFACTURER REQUIREMENTS - GAS EQUIPMENT VENTING SYSTEM NOT PROVIDED. When the manufacturer of a Product Approved side wall horizontally vented gas fueled equipment does not provide the parts for venting the flue gases, but identifies “special venting systems,” the following requirements shall be satisfied by the manufacturer:
1. The referenced “special venting system” instructions shall be included with the appliance or equipment installation instructions; and
 2. The “special venting systems” shall be Product Approved by the Board, and the instructions for that system shall include a parts list and detailed installation instructions.
- (e) A copy of all installation instructions for all Product Approved side wall horizontally vented gas fueled equipment, all venting instructions, all parts lists for venting instructions, and/or all venting design instructions shall remain with the appliance or equipment at the completion of the installation.
-



Lexington Forge warrants its products to be free of defects in material and workmanship and backs each product with a Limited Lifetime Warranty. This warranty is to the original purchaser of a Lexington Forge product and is not transferable.

LIFETIME WARRANTY

Covered under this warranty are the stove body, combustion chamber, door frame, gold plating (manufacturing defects only), glass (thermal breakage only), heat exchange system, and burner. This coverage includes parts and reasonable labor during the first five years of ownership and parts only thereafter.

FIVE YEAR WARRANTY

Ceramic fiber logs, firebrick panels and secondary air tubes are covered for a period of five years from the date of purchase.

TWO YEAR WARRANTY

Gas valves, pilot assemblies, thermopiles, thermocouples, regulators, electrical components, cast iron grates and blowers are covered for a period of two years from the date of purchase.

EXCLUSIONS

Items that are not covered under this warranty include but are not limited to damage or chipping to any component surfaces, gasketing, refractory material, or trim. It does not cover installation or operational problems related to venting systems, inadequate draft, inadequate gas pressure, adjustments to the appliance, the cost of inspection, components which have been altered or modified, labor costs, removal and re-installation costs, shipping to or from the factory or authorized service center, shipping damage, damage from improper use or neglect, installation damage, damage from unauthorized service, incidental or consequential damage or negative pressure caused by mechanical systems such as furnaces, fans, clothes dryers etc.

TERMS

This warranty shall be void if the appliance is not installed by qualified installer in accordance with the installation instructions provided with the appliance and state and local codes. The warranty shall also be void if the appliance is not operated and maintained in accordance with the operating instructions supplied with the appliance. All service work must be performed by an authorized service representative. Any part or parts, which we deem defective, will be repaired or replaced at Lexington Forge's option, through an authorized dealer or service provider.

This warranty is expressly in lieu of other warranties, express or implied, including the warranty of merchantability of fitness for purpose and of all other obligations or liabilities. Lexington Forge does not assume for it any other obligations or liability in connection with the sale or use of the appliance. In states that do not allow limitations on how long an implied warranty lasts, or do not allow exclusion of indirect damages, those limitations of exclusions may not apply to you. You may also have additional rights not covered in this Limited Warranty.

Lexington Forge reserves the right to investigate any and all claims against the Limited Warranty and decide upon the method of settlement.

Lexington Forge • 149 Cleveland Drive • Paris, KY • 40361