

Module EXTender™ for Norstar®

Extend the reach of your Nortel Norstar® system to different floors or different buildings

The Module EXTender is a reliable and economical alternative to linking Norstar Station or Trunk Modules in scenarios usually requiring the costly purchase of second Norstar system.

Connects station modules up to 1.9 miles from the KSU.

No additional devices required.

Connects single stations or a 10-unit star configuration.

Simplifies troubleshooting issues.

Works over copper and short-fiber connections.

Controls wiring costs.

Supports older 8 x 24 modular Norstar equipment.

Product Overview

Alternative extension methods attempt to stretch the distance to each individual digital station set. This distance, the “TCM station loop”, runs out of gas between 1000 and 2600 feet (304-792 meters). Building-to-building TCM extension requires costly specialized devices for loop protection. This means the old way of extending service to more than a few sets quickly becomes cost prohibitive, and leaves users with few, if any, of the optional Norstar® features. Module EXTender™ eliminates these limitations.

Module EXTender is a pair of small surface or wall mount units that receive the standard Nortel DS-30 signals over copper or short fiber, and retransmit them with enough strength to drive multi-mode long fiber over three kilometers. Now a remote Station or Trunk Module can extend all your Norstar® features, applications, and peripherals almost 1.9 miles from the Key System (KTS). Whether on the seventh or seventieth floor, every workgroup will have access to the same voicemail, ACD, or other functions as those on the main floor.

Product Features

Extends the reach of Norstar® Station or Trunk Modules over 1.9 miles.

Allows expansion of older 8 x 24 modular Norstar® units.

Allows sharing of system features and peripherals.

Increases reliability and helps control wiring costs.



Key Benefits

Increased Productivity

Users up to 1.9 miles from the KTS get fully featured digital sets and all corporate KTS features and applications.

Network Efficiency

Unified system approach provides a more efficient use of network resources. Simplifies troubleshooting and maintenance by providing a common network access point.

Cost Effectiveness

No costly specialized devices for loop protection required. Cost savings from reduced wiring requirements.

Flexible Configurations

Single remote locations, or up to 10 remote locations in a star configuration.

Technical Specifications - Module EXTender™ for Norstar®

General Specifications

Product is supplied with one 2.1 meter short fiber cable for connecting the local unit to the KTS.

Customer supplies multi-mode long fiber (Corning Cable Systems, formerly SIECOR, #2K81-31130-24 or equivalent) to connect local and remote units.

Local and remote units may be separated by up to 3 km (almost 1.9 miles).

Depending on configuration, up to 10 remote Norstar® Trunk or Station Modules may be connected with Module EXTenders.

Each Module EXTender pair supports up to 16 digital handsets (Station Module) or eight (8) analog handsets (Trunk Module).

Form factor: small footprint, desk- or wall mountable. Size: 4.5" x 8" x 1.5"

Applications

Office or institutional campus.

Mail type settings.

Distributed workgroups on multiple floors.

Large manufacturing or warehouse facility.

Sample Network Configuration

Single Remote Location

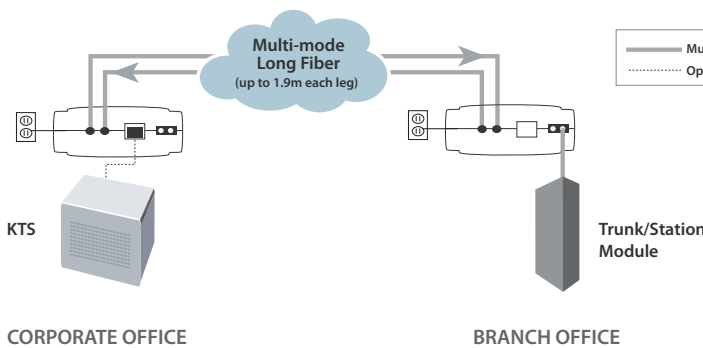

Distributed Star

Uses one Module EXTender pair for each branch. Up to 10 branches, each up to 1.9 miles (3km) from Key System location.

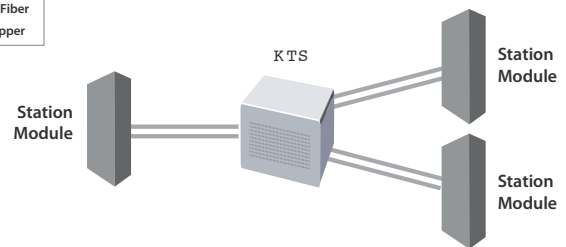

MDEX-0807

Citel. The VoIP Migration Company™

Corporate Headquarters

3131 Elliott Avenue
Suite 250
Seattle, Washington
98121 USA

Phone: +1 206 957 6270
Fax: +1 206 957 6275

European Headquarters

Wheatcroft Business Park
Unit 4, Landmere Lane
Edwalton Nottingham
NG12 4DG United Kingdom

Phone: +44 (0)115 940 5444
Fax: +44 (0)115 940 5664

Canadian Headquarters

4040 Bowness Road N.W.
Calgary, Alberta
T3B 3R7 Canada

Phone: +1 403 247 9777
Fax: +1 403 247 9078

For More Information

Contact Citel Directly

sales@citel.com

Phone: +1 206 957 6270
Toll Free: +1 877 248 3587

citel.com

Regional Offices

Atlanta, GA • Boston, MA • Chicago, IL • Dallas/Ft. Worth, TX • Denver, CO • Hartford, CT • Jacksonville, FL • Nashville, TN • Washington, DC • Wilmington, NC