

# 0903-0080 BULL BAR

## Components List:

- 1 – Bull Bar Assembly
- 2 – Bracket, Driver and Passenger Side
- 2 – Plastic Plug
- 4 – Rubber Bumper

## PARTS LIST:

- 4 – M10 \* 30mm Socket Head Cap Screw
- 4 – M10 Flat Washer
- 4 – M10 Lock Washer
- 4 – M10 Hex Nuts

## Installation Instruction:

1. Remove all contents from the received box and check tube for any dent. Also verify all brackets and bolts against the parts list.
2. Read installation manual and installation drawing completely. Understand all brackets and bolts before installation.
3. It may be necessary to remove/relocate front license plate and license plate bracket. If local/state law requires a license plate, license plate relocation kit 0900-0001 is available. License plate bracket must be removed on 2005 and newer vehicles.
4. Determine passenger and driver bracket. See figure 2. Locate and remove front bumper bolts that support the bumper to vehicle. Note: It may be necessary to hold the factory nut plate from the rear of the bumper to keep it in place. Attach brackets to bumper and reinstall bolts.
5. Attach bull bar to brackets using M10 bolt sets as shown. Level and adjust bull bar as desired.
6. Light installation: Insert threaded stud on base of the light through hole in cross tube. Using a ratchet, extension and socket for correct size of nut supplied, insert through large clearance hole in bottom of cross tube. Thread nut and washers on stud and tighten. See figure 1.

7. Fits most 6" round or rectangle lights. Some lights may require replacing included mount/isolator with rubber bumpers provided. Mounting stud of  $\frac{1}{2}$ " or less required. Plug mount holes with caps provided if not installing light.

0903-0080

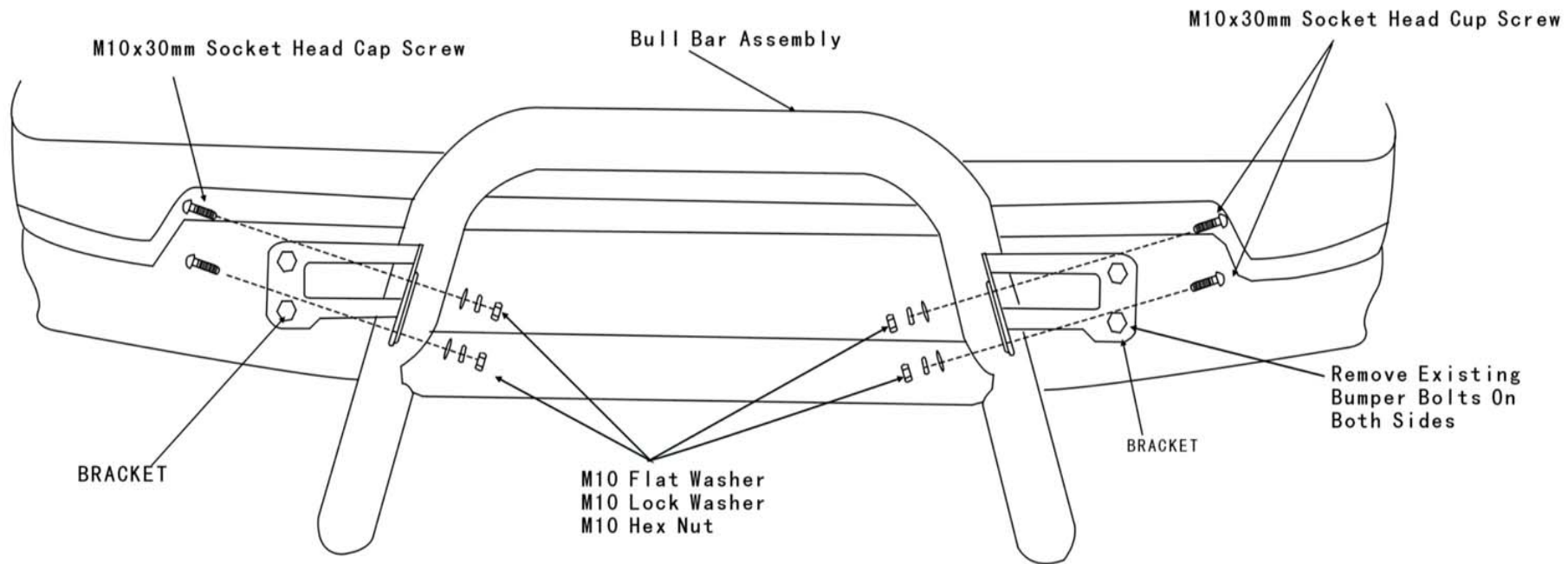
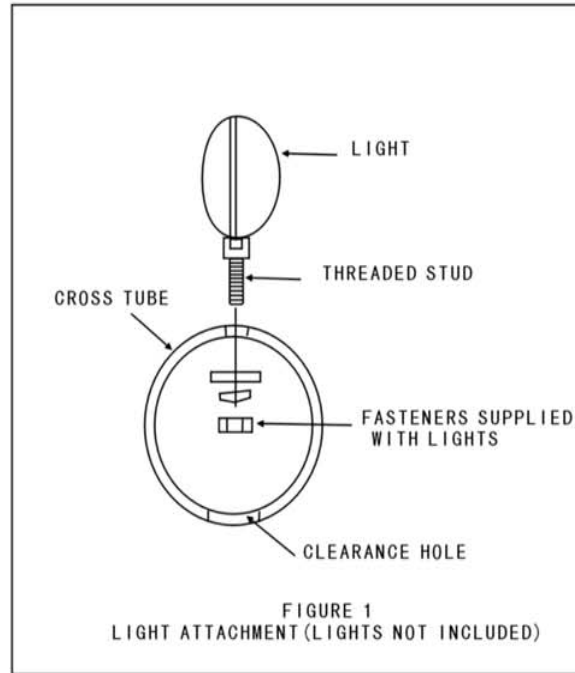

FIGURE 2