

WoodburningTM Kit

Trace It! Burn It! Paint It!

- The paints in this set are very high quality, nontoxic, permanent acrylics and may permanently stain fabrics.
- Take precautions against spills. Cover your work surface and wear a smock. If you get paint on your clothes or carpet, wash immediately.



NOTE TO PARENTS:

While every precaution has been taken into the manufacturing of this product, we recommend that the product be periodically examined for potential hazards and that any potentially hazardous parts be repaired or replaced.

ATTENTION:

Your product is equipped with a polarized alternating-current line plug (a plug having one blade wider than the other). The plug will fit into the power outlet only one way. This is a safety feature. If you are unable to insert the plug fully into the outlet, try reversing the plug. If the plug should still fail to fit, contact your electrician to replace your obsolete outlet. Do not defeat the safety purpose of the polarized plug. Do not try to force a plug into an outlet.

**CAUTION: ELECTRICALLY
OPERATED PRODUCT**

**NOT RECOMMENDED FOR CHILDREN UNDER 13 YEARS OF AGE.
POINT BECOMES HOT. DO NOT TOUCH POINT OR METAL PIECE.
AS WITH ALL ELECTRIC DEVICES, PRECAUTIONS SHOULD BE
OBSERVED DURING HANDLING AND USE TO PREVENT
ELECTRIC SHOCK.**

**DANGER: TO PREVENT ELECTRIC SHOCK,
DO NOT IMMERSE IN WATER.**

ELECTRICAL RATINGS, 110/120 VOLTS AC-22 WATTS-60Hz

No. 7733-08
Printed in CHINA

© 2007 NSI International, Inc., Farmingdale, NY 11735-1318

This Product is Listed by
UNDERWRITERS LABORATORIES INC.
and Bears the Mark:



Your set includes the following items:

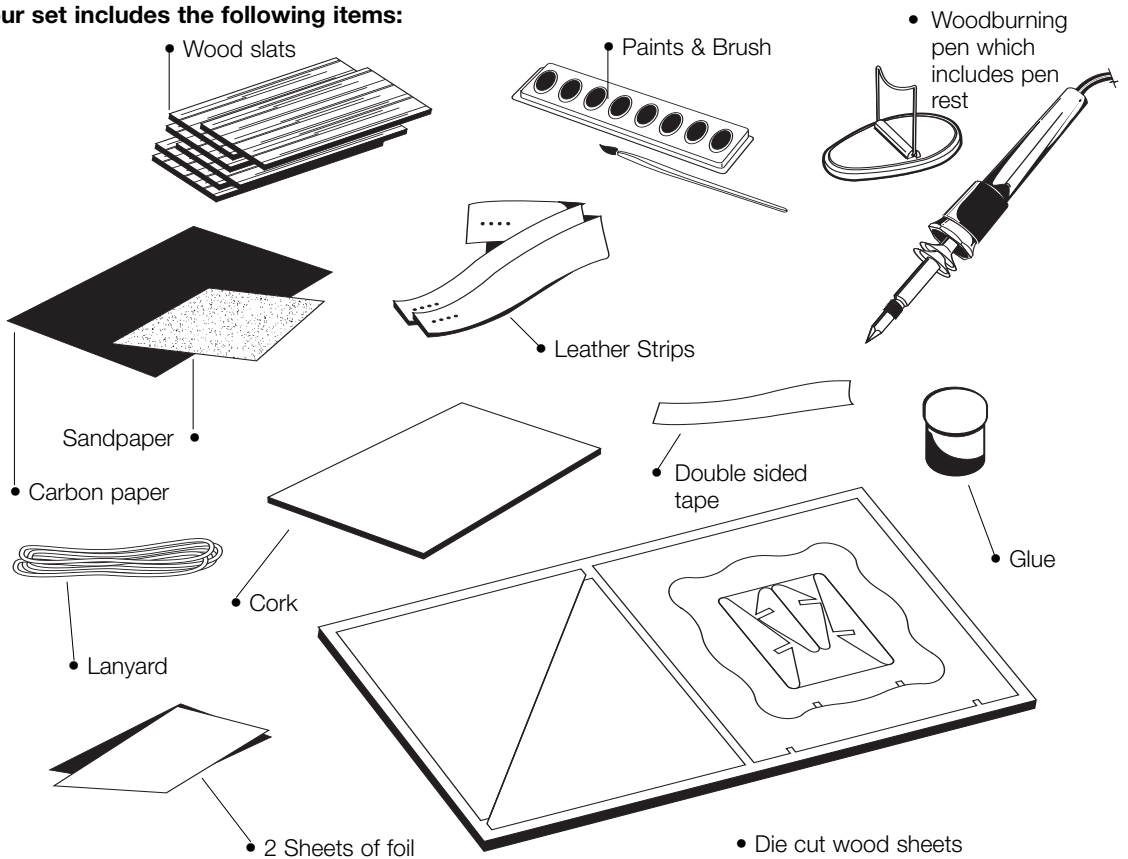

PREPARATION

Read all the instructions before starting your project. We recommend organizing your supplies on a suitable working area such as a kitchen table, preferably close to a regular 110/120 volt outlet. Place everything on sections of newspaper for quick and easy cleanup. Never put a hot Woodburning pen down on a paper, plastic or a wooden surface.

Before using your electric Woodburning pen, examine it carefully for any frayed, broken, damaged wire, parts, etc. Do not use if you suspect that repairs or replacements should be made.

Never touch the metal tip, even when unplugged. Wait fifteen minutes for those areas to cool. Hold the pen at the rubber portion only. Never touch a hot Woodburning pen to any part of the body. Always work on a flat clean surface. Never leave Woodburning pen plugged in unattended, or in the presence of small children and pets. Always use the special pen rest when putting down your Woodburning pen.

ORGANIZE YOUR SUPPLIES

Locate the parts shown above and organize your Woodburning pen, wood slats, leather, cork, foils, paints and paint brush.

HELPFUL HINTS

1. Your pen gets hot. Don't touch the point.
2. The slower you go, the darker the line.
3. Move the wood to get the correct angle or position for burning.

4. Always move the pen towards you.
5. Practice on the back of your work or on a scrap.
6. Learn to hold the pen lightly.
7. Do all cutting and sanding of wood before burning or painting.
8. Periodically run the tip of the pen across sandpaper to remove carbon build up.
9. Before using colors on your work, it is a good idea to use a sealer on the wood. This will ensure that the colors do not run. (sealer not included)
10. Individual techniques can be developed by each user. There are no set patterns for woodburning that must be followed. Use your creativity and imagination.

1. HOW TO SET UP THE WOODBURNING PEN

Your Woodburning pen comes with a permanent slanted tip which is used for Woodburning and foil embossing. (See Below)

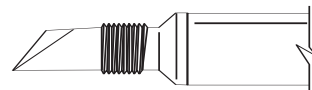

Tool Rest: Your woodburning pen comes with a tool rest. Lift the metal piece up so that it stands up in the air at a small angle. Always use this tool to rest your Woodburning pen while it is plugged in and hot.

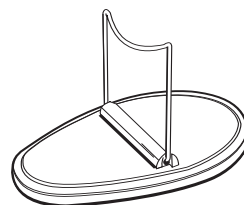

2. HOW TO TRANSFER DESIGNS

To Wood and Cork:

- 1: Select a picture you like at the back of this booklet.
- 2: Place carbon paper with shiny side down on wood slat or cork piece. The edge of the carbon paper should line up with the edge of the wood or cork.
- 3: Place the picture to be transferred on top of carbon paper. Hold in place with tape or your hand.
- 4: Carefully trace over picture with ball point pen or pencil.
- 5: When all outlines of the picture have been traced, remove carbon paper and picture. Put aside for future use.

To Leather:

- 1: Select a picture at the back of this booklet that is designed specifically for leather.
- 2: Place the leather with the smooth side up on a surface, like a wooden cutting board.
- 3: Dampen the leather all over with a sponge dipped in cold water. Do not soak the leather.
- 4: Place carbon paper with shiny side down on leather.
- 5: Place the design pattern over the leather so that it fits correctly into the area to be decorated and hold in place with your hand.
- 6: Carefully trace over the picture with ball point pen or pencil.
- 7: When all outlines of the picture have been traced, remove the carbon paper and picture. Put aside for future use.

3. HOW TO USE THE WOODBURNING PEN

To familiarize yourself with the Woodburning pen, practice different techniques on the unprinted sides of the plaques or on some scrap wood. Smooth all the rough edges with sand paper. Hold the pen as you would a large sturdy marker. Do not use more pressure than when using a strong pencil, as the depth of the burning does not depend on the pressure, but the length of time the pen point is in contact with the wood. **Caution: Do not touch the tip of the pen until the unit has been unplugged and allowed to cool down for at least fifteen minutes.**

When working on a design, always work towards yourself with the pen at a slant as when writing with a regular pen. Follow the outline of the picture with the point or the sharp edge by always moving the tip towards you. With practice you will find it easy to move the pen sideways and around corners and curves by holding the pen straighter and leaning it slightly. Regulate the depth and width of your line by moving faster or slower, by adjusting the angle of the pen and by moving the wood around with your other hand. Experiment on a piece of scrap wood for different patterns and effects.

4. HOW TO DESIGN LEATHER BRACELETS AND CORK

Select an appropriate pattern from this instruction booklet and transfer onto a leather strip or cork, as described earlier. With your Woodburning pen, burn in over the pattern to create a desired effect.

To attach your bracelet take the enclosed piece of lanyard and cut it in half. Wrap the bracelet around your wrist and align the holes at both ends to make the best fit. Thread the lanyard through those holes on each end and tie a knot.

To use the cork as a bulletin board, cut out a piece of corrugated cardboard from your package insert the same size as the piece of cork. Glue or tape the cork to the cardboard to create a thicker backing. Now you can use push pins or thumb tacks on the cork to hang notes. Be careful not to push pins too far into the cork or they may come out the other side and cause damage to walls.

5. HOW TO PAINT

Your Woodburning set comes with a paint brush and paint strip so that you may color your projects. All paints are water colors and will require a cup of water to clean your brush. Have fun and be creative! If paints get on clothes, wash clothes immediately. Do not paint over carpeting or upholstery. Use paints over a vinyl or tile floor, such as a kitchen floor. Always work on top of newspapers and wear a smock. **Do not use pen near water. Do not immerse pen in water or make contact with water to avoid death or shock.**

6. PROJECTS: HOW TO MAKE A LETTER HOLDER

Using three plaques or pieces of wood, a simple but decorative napkin holder or letter holder may be made. Make sure the two standing sides are the same size. Use wood or craft glue.

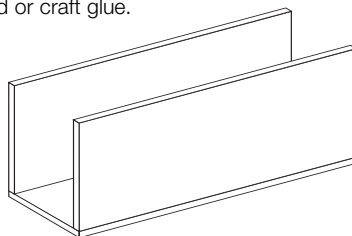

You can make a large variety of Woodburning projects by trimming your wooden pieces with a saw and sanding the rough edges. (saw not included) You can also buy wood at a craft store or lumber yard to make your own unique projects. Have fun, be creative, and remember, don't touch the hot pen tip.

7. HOW TO MAKE 3-D PROJECTS

Locate the large flat wooden sheet with the patterns printed directly onto the wood. Select which project you'd like to make and punch out the parts. See the following illustrations to determine which pieces go together. As described above, burn the wood by following the printed outlines. Feel free to shade and texture your project as you like. Paint and assemble your 3-D figures as described in this instruction manual.

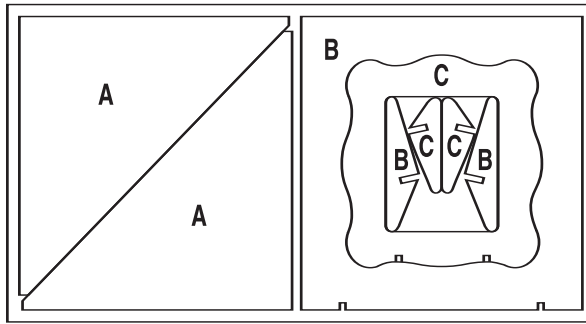

8. HOW TO MAKE A 3-D CD HOLDER

Affix four pieces of plank wood with glue as shown in figure 1. Next find all pieces labeled A. Follow the diagram below to attach sides of CD holder with glue.

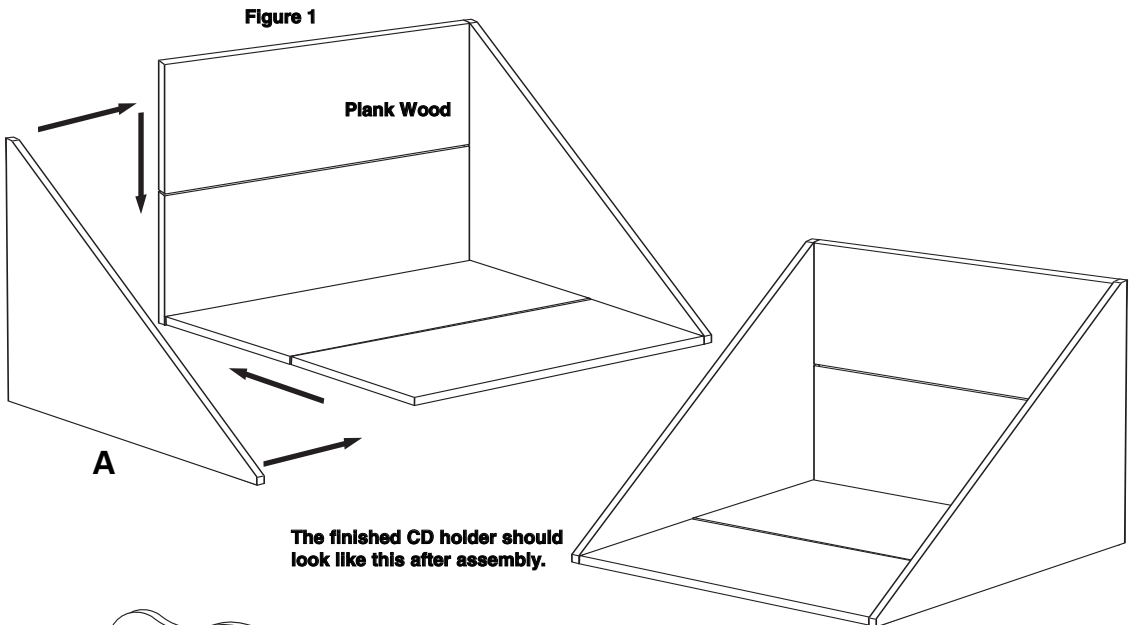

The finished CD holder should look like this after assembly.

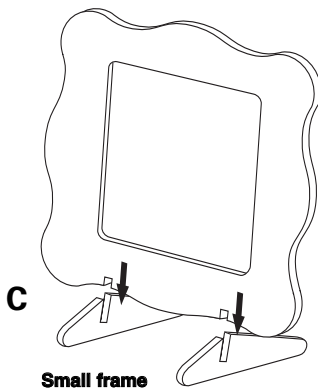

Small frame

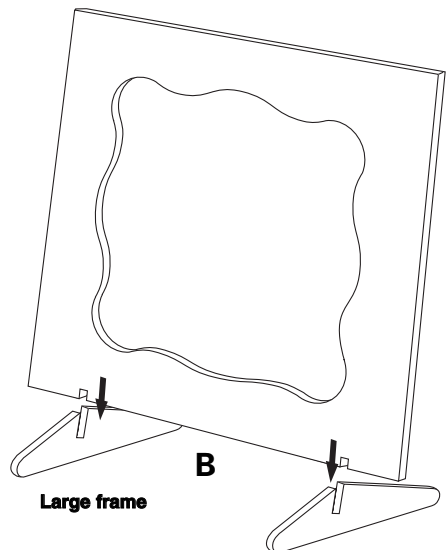

Large frame

9. HOW TO MAKE A LARGE & SMALL PICTURE FRAME

1. To make a large frame, find all parts labeled B and put together as illustrated.
2. To make a small frame, find all parts labeled C and put together as illustrated.

General- Make sure glued pieces dry before putting on the next piece.



Leather Patterns

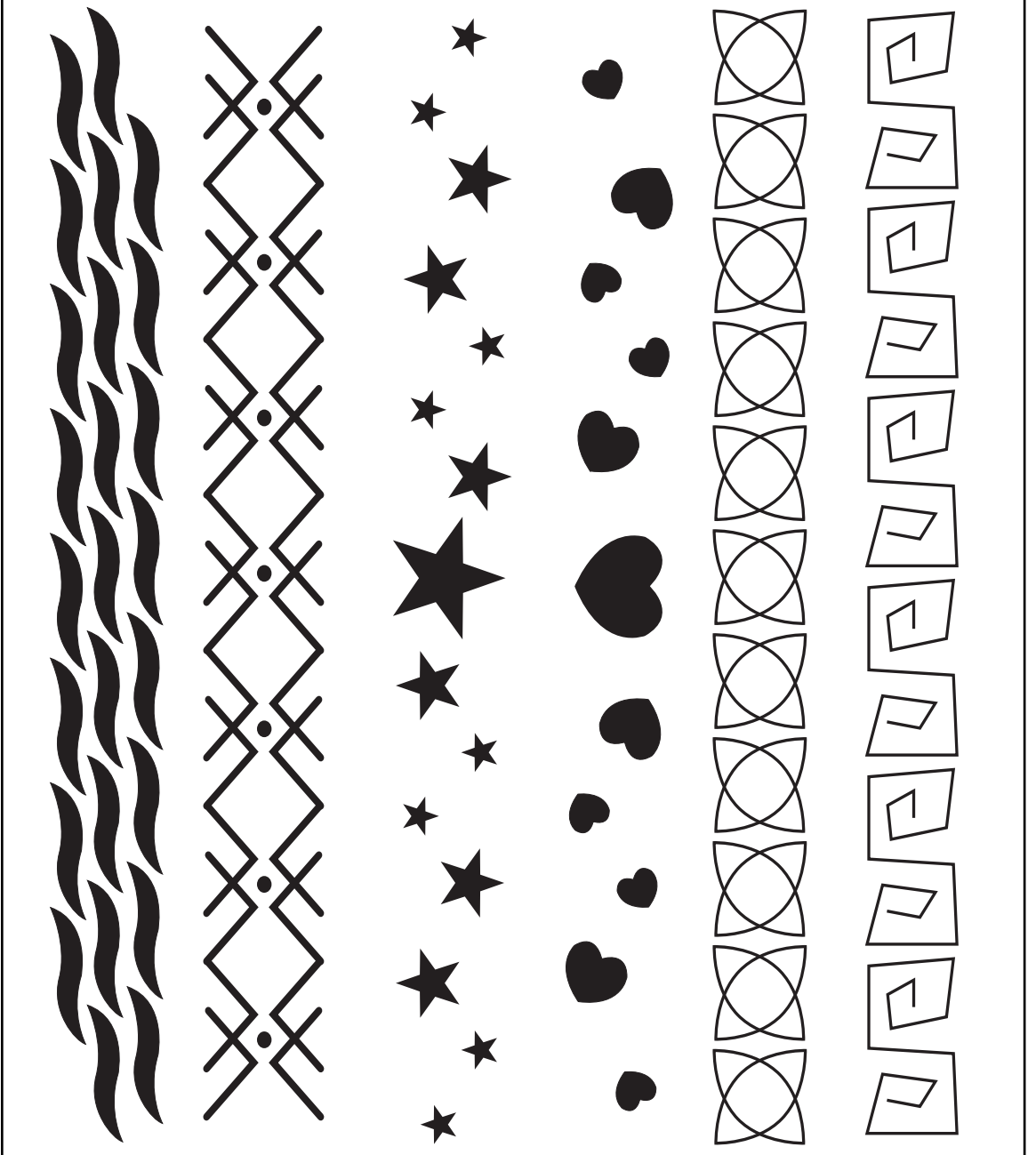

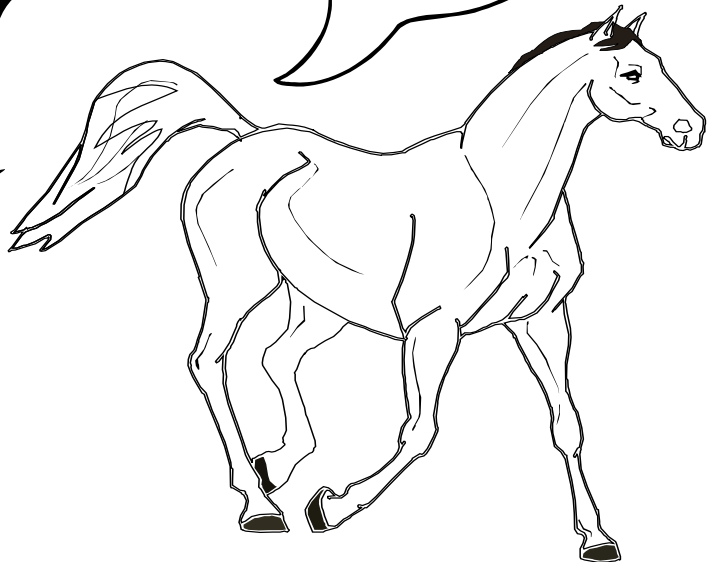
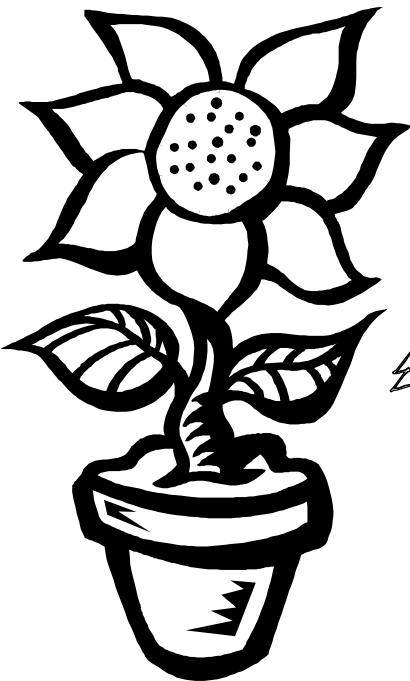
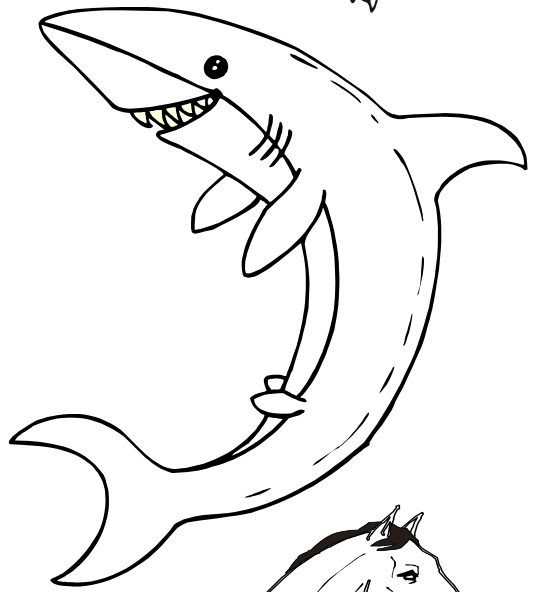
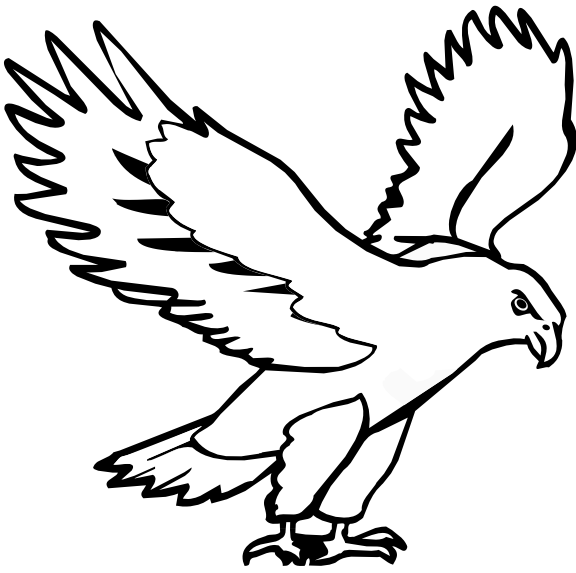
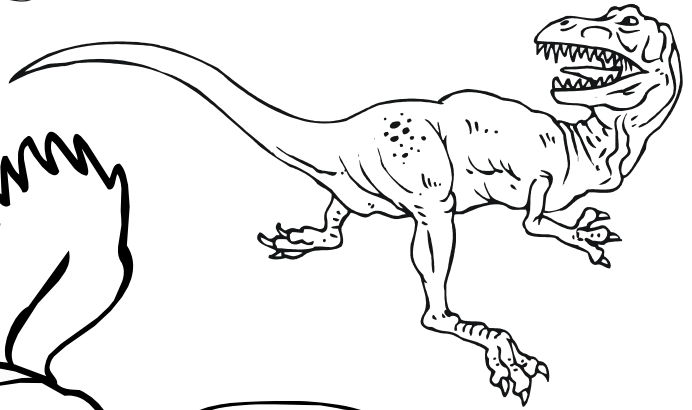
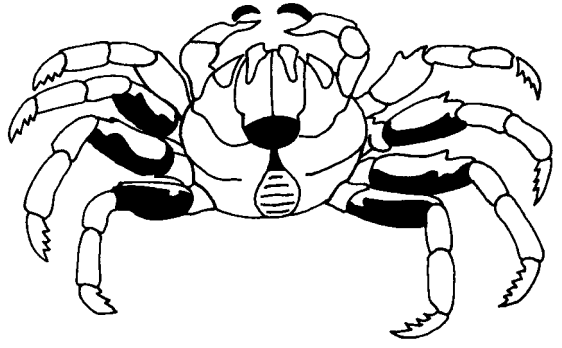
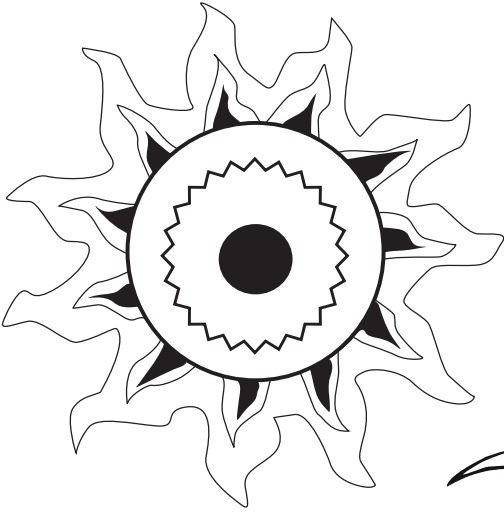

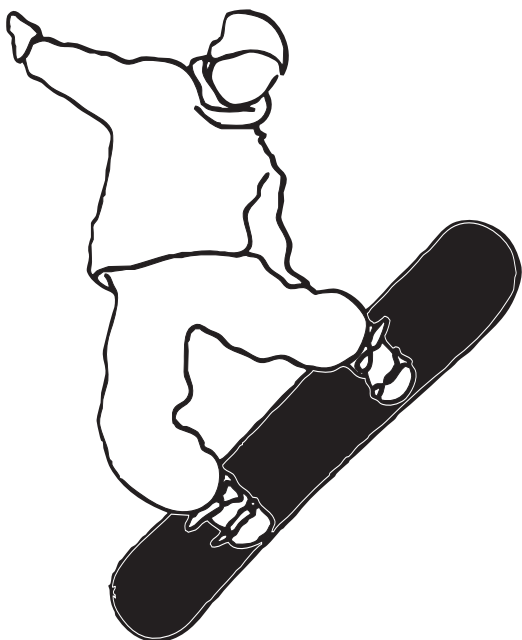
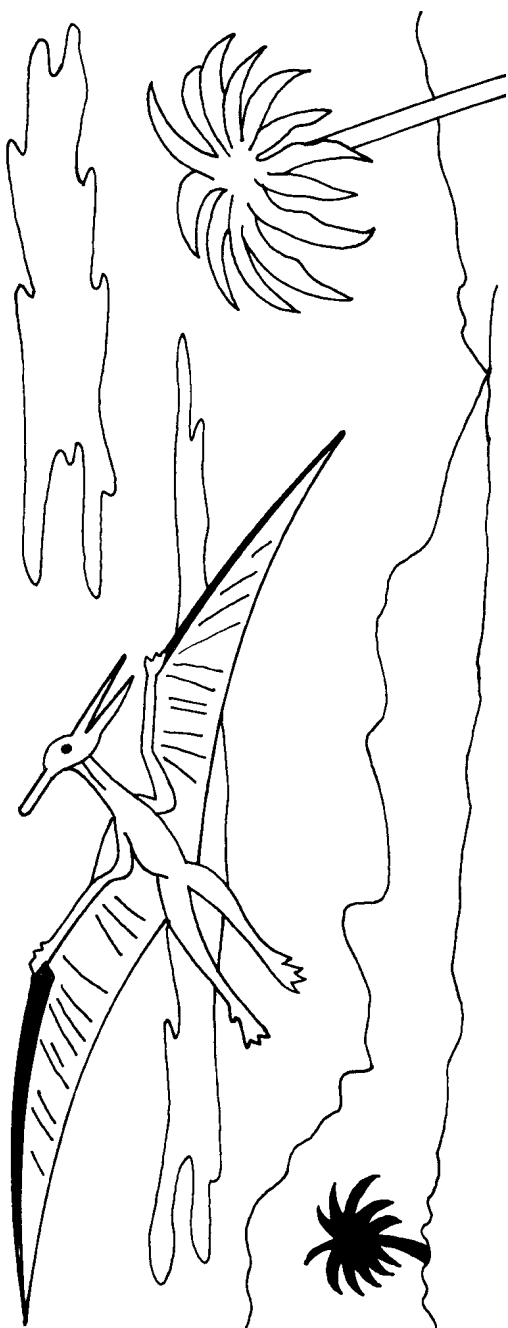
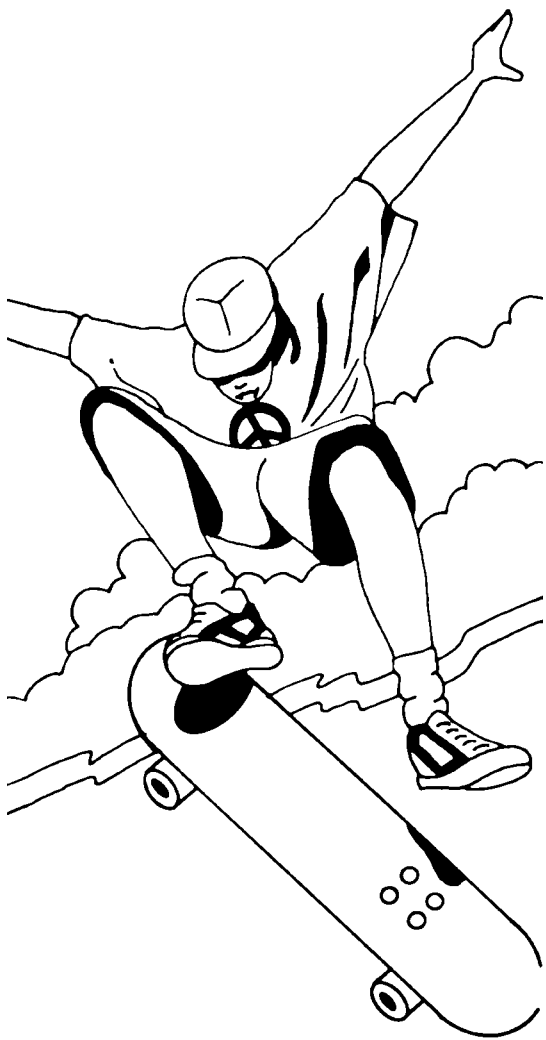

Dear Customer:

We hope you enjoy our Woodburning kit. If you find that we made an error or something is missing or damaged, we are sorry and wish to correct our error. Please DO NOT return the set to the store where purchased, as the store does not have replacement parts. Instead, write to us:

PLEASE INCLUDE:

- 1. Date of Purchase**
- 2. Where Purchased**
- 3. Price Paid**
- 4. Model Number**
- 5. Name of Item**
- 6. Brief Description of Problem**
- 7. Include Sales Slip**

We will do our best to satisfy you.

Send your letter to:

NSI International, Inc.
105 Price Parkway,
Farmingdale, NY 11735-1318.
Attention: Quality Control Department.
Tel: (631) 501-7550
Website: www.nsi-int.com

To order additional supplies please charge or send check or money order to:

NSI International, Inc.

105 Price Parkway
 Farmingdale, NY 11735-1318.

Please allow two extra weeks for check processing
 We now accept Visa and MasterCard
 Do Not Send Cash

 Name on Card

 Exp. Date

 Card No.

 Signature (must be signed to be valid)

 Phone #

 Name

 Address

 City State Zip

Item #	Item Name	Price	Quantity	Total
279-07	8 Large Wood Sheets	\$1.25		
7797-41	Red & Blue Colored Foil	\$0.25		
7733-02	Gold Foil	\$0.25		
7797-02	Cork Sheet	\$0.75		
279-14	Paintbrush	\$0.50		
7797-06	2 Leather Bracelets	\$0.60		
7733-06	Paint Stringer	\$2.50		
9361-13	Lanyard	\$0.25		
9345-18	Double Faced Tape	\$0.25		
7770-01	Woodburning Pen	\$7.00		
279-06	Sandpaper	\$0.25		
7733-09	Carbon Paper	\$0.25		
279-13	Glue	\$0.25		
<small>(Colors and contents may vary)</small>				
Add Shipping & Handling				\$5.00
Total				\$



NSI International, Inc.
105 Price Parkway,
Farmingdale, NY 11735-1318.
Attention: Quality Control Department.