

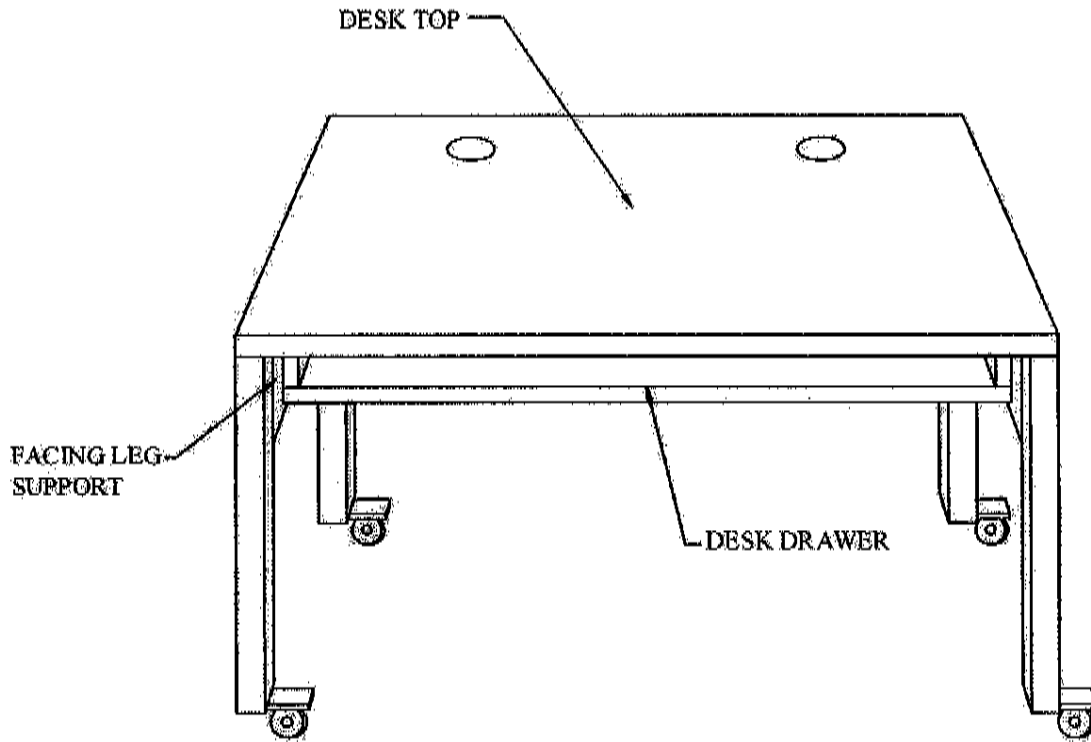







POCKET DESK ASSEMBLY INSTRUCTION



COMPONENTS:

1 carton	Desk Top
1 carton	Desk Drawer
	Desk Beam
	Right/Left facing Leg Support w/casters
	Carton box with : Hardware package
	Casters
	Magnetic catch
	Carton box with: Slides

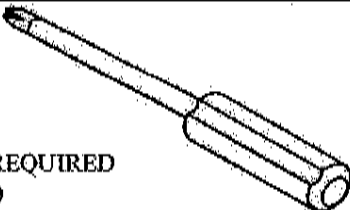
HARDWARE:

<p>MAGNETIC CATCH WOOD SCREWS TC+4x20</p>  <p>4</p>	<p>BUTTON HEAD MACHINE SCREWS - SOCKET HEAD 6MAx16</p>  <p>8</p>	<p>BUTTON HEAD MACHINE SCREWS - SOCKET HEAD 6MAx25</p>  <p>18</p>	<p>SMALL DRAWER SLIDE WOOD SCREWS TC+4x16</p>  <p>8</p>	<p>SMALL DRAWER SLIDE MACHINE SCREWS 4MAx12</p>  <p>6</p>
<p>PHILLIPS HEAD SCREWDRIVER REQUIRED (NOT PROVIDED)</p> 		<p>ALLEN WRENCH FOR BUTTON HEAD SCREWS</p> 		

DESK ASSEMBLY

1. Unpack all components. Unpack the desktop and turn upside down so that the boring is face up (use the provided carton and protective pack). Attach the (2) magnetic catches as shown in FIG.1 using the small #4X20 (3/4" long) wood screws (4 provided). Make sure the horizontal magnetic bars on the catch are facing the back edge of the top.
2. Layout the Leg Supports as indicated in FIG. 2 – using the 6MAX25 (1" long) machine screws (18 provided) match the plates to the table boring pattern. Note there's a left and right leg support. Make sure the cut-out between the plates is closest to the back of the desk top. The back of the desk top is easily identified by the grommets and magnetic catches. Leave the screws slightly loose – you will tighten them down to the top surface once the center beam is attached in Step 3. You will need some adjustment as you slide the desk beam into place.
3. Slide the desk beam into place between the leg supports. Note that the hinged drawer faces the back of the legs (this is opposite of the drawer slides). Attach the desk center beam to the side leg supports using the 6MAX16 (5/8" long) machine screws (8 provided). Make sure you use 4 per side as shown in FIG. 3. It is a good idea to place all of the screws just finger tight before using the allen wrench to lock them down firmly. Note there are 2 hidden on each side – inside the back lid section. Lift the lid and place the 4 screw and tighten as required. The lid closes against the magnetic plates that were mounted to the top of the desk in Step 1. Be careful when turning the desk over as the rear hinge moves freely. (using masking tape you can tape it in a closed position when turning over the desk to its upright position). Use the provided allen wrench and tighten the screws securing the center desk beam to the leg supports. Now place the remaining 6MAX 25 (1" long) machine screws securing the desk beam to the top as shown in FIG. 3. Using the allen wrench provided make sure all of the screws are tight before continuing to step 4.
4. Screw in the casters to the ends of the steel legs. Make sure they are tight and seated against the leg bottom, hand tighten. Now attach the drawer slides using the (6) small 4MAX12 (3/8" long) machine screws (see ****IMPORTANT**). Extend the slides fully into their locked position. Attach the first 2 screws in the rear holes as shown in FIG.4. Note the green button faces out and to the front of the side. Now push in on the green button and push the slide partially closed until the front screw hole is exposed as shown in FIG.4. Note that the slide when correctly attached sits back from the leg to allow the drawer to slide in.
5. Turn the desk to its upright position once the base assembly is secured. Step on the locking casters so the desk will not move. Pull the slides out by hand until they lock into their extended position. Slide the desk drawer unit onto the extended slides and using the small wood screws 4X16 align the pre-bored holes and tighten. There are 3 per side. Tighten firmly.
6. Once the drawer is secured – reach to the outside of the drawer (both sides at once) and push-in on the green button – while pushing on the drawer body. The drawer will slide into the desk unit.
7. To move the desk – unlock the casters – it will move easily on the hardwood or carpeted surfaces. Note that the casters are double locking as the lock engages it locks the wheel from spinning and the caster also from spinning. Always lock the casters when using the extended drawer surface.

****IMPORTANT (the screws provided in the drawer slide box are not used for assembling the desk and may be thrown out).**

CARE AND MAINTENANCE

Wood surfaces (desktop and drawer). The desk and drawer are constructed of maple and cherry veneer and solid hardwoods. To clean use a soft cloth and a furniture polish or just a damp cloth wiping dry immediately. Do not let liquids stand on the wood surfaces as it may cause discoloration or a moisture ring.

Metal surfaces. All metal surfaces are a durable powder coated (silver) and can easily be cleaned with a damp cloth or "highly" recommended is Windex Glass cleaner which will remove any finger or handprints. Always use a soft cloth.

Drawer Slide Maintenance. The special locking double extension slides are pre-lubricated and should not require additional lubrication. This slide is custom designed to carry extended loads and has 2 inner metal bearing sleeve assemblies. On occasion these assemblies can be slightly out of sync with each other and the drawer may seem difficult to close. Note this is normal – the bearing mechanisms are easily re-aligned by pushing the drawer fully closed. Push the drawer closed in its seated (fully closed) position – don't be afraid to use force. This will automatically re-position the bearing assemblies.

DESK ASSEMBLY INSTRUCTION

020620

1

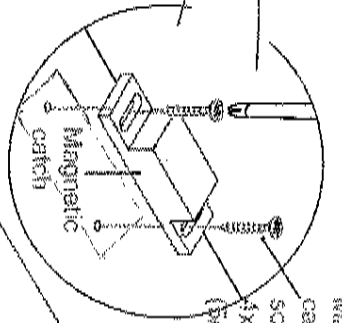
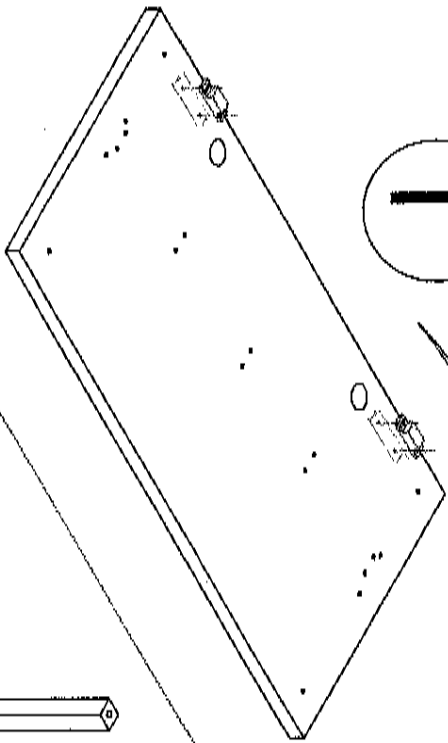

Magnetic catch wood screws TC 4x16 (3/8" long)

2

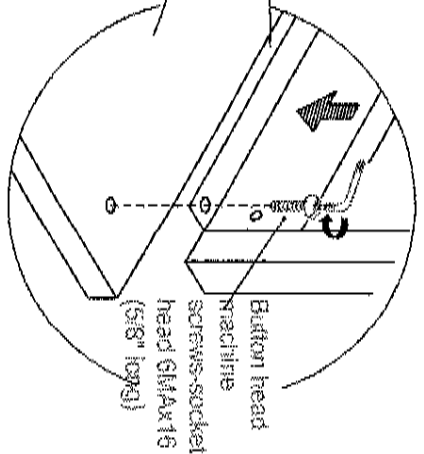
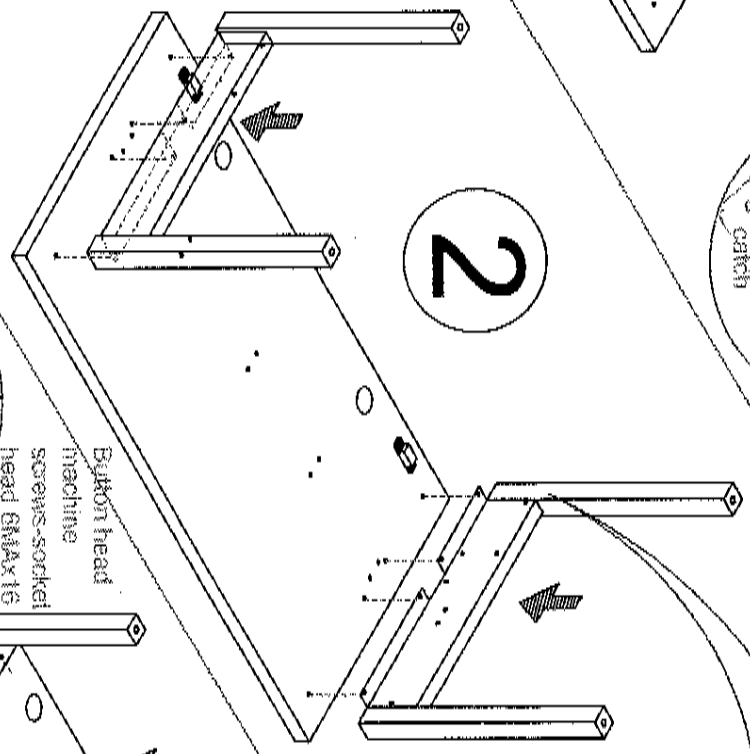

Button head screws-socket head 6MMx16 (5/8" long)

3

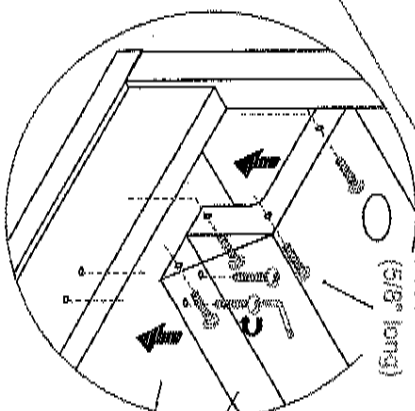

Button head screws-socket head 6MMx16 (5/8" long)

4

green button

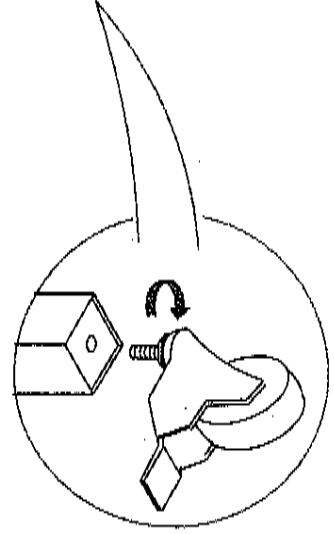

Small drawer slide wood screws TC 4x10 (not shown)

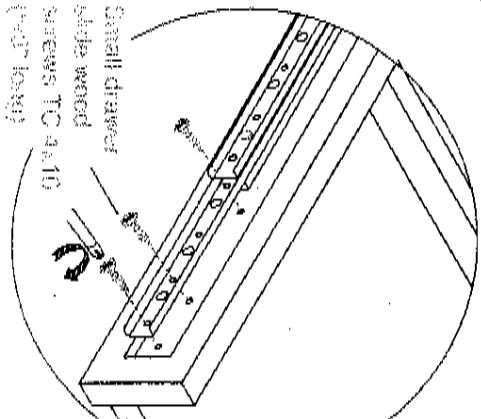

5

