

REVISION HISTORY			
REV	DESCRIPTION	DATE	APPROVED

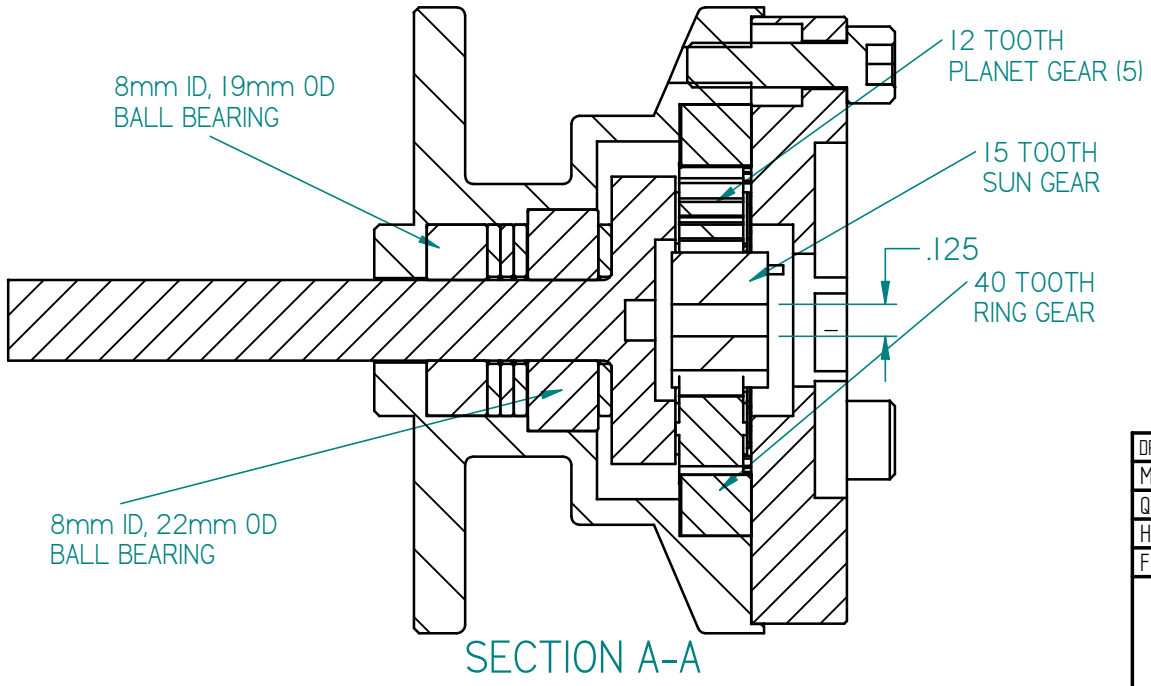
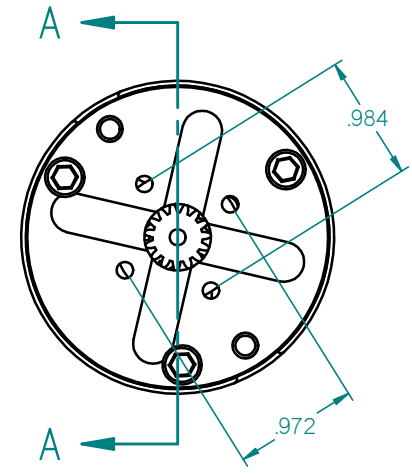
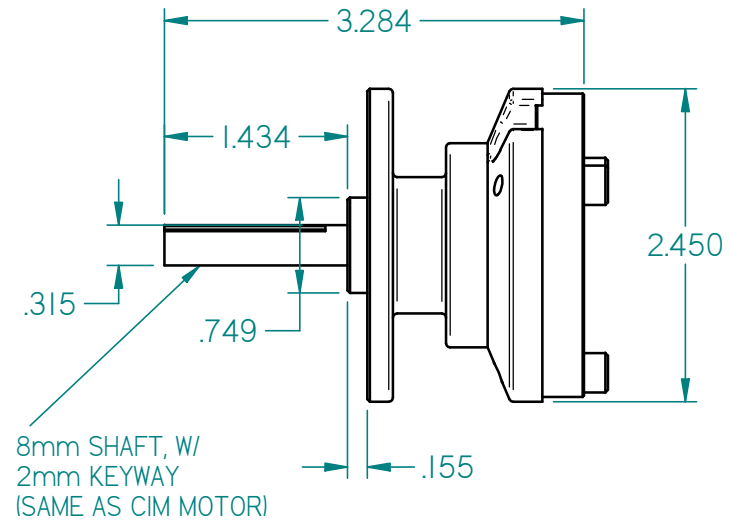
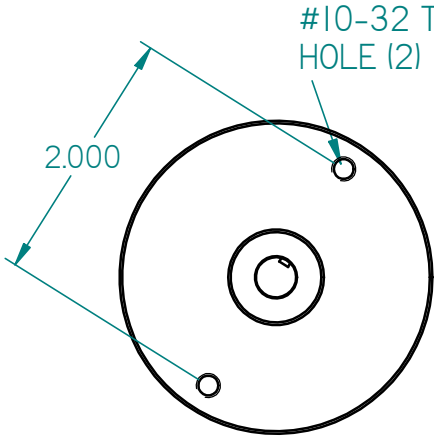

3.67:1 GEAR REDUCTION
ACCEPTS FISHER-PRICE MOTOR,
GLOBE MOTOR, CIM MOTOR

DRAWN	Andy Baker	05/05/09	ANDYMARK.BIZ STANDARD SOLUTIONS FOR COMPETITION ROBOTS TITLE AM Planetary V.2		
MATERIAL					
QUANTITY					
HEAT TREAT					
FINISH			SIZE A3	DWG NO AM Planetary2	REV 2
UNLESS OTHERWISE SPECIFIED DIMENSIONS ARE IN INCHES ANGLES ±0.5° 2 PL ±0.01" 3 PL ±0.005"			FILE NAME: AMPlanetary2.dft	SCALE:	WEIGHT:
			SHEET 1 OF 1		