

AUDIO KIT

INSTALLATION INSTRUCTIONS

Vehicle: MAZDA5
Parts numbers: CG37 79 EGX (WMA-6CD unit)

Thank you for purchasing a genuine Mazda accessory.

Before removal and installation, be sure to thoroughly read these instructions.

Please read the contents of this booklet in order to properly install and use the audio kit. Your safety depends on it.

Keep these instructions with your vehicle records for future reference.

Note:

- There are several **⚠WARNING** and **⚠CAUTION** sections in this booklet concerning safety when installing or removing the audio kit. Always read and follow them in order to prevent injuries, accidents, and possible damage to the vehicle.

⚠ WARNING: Indicates a situation in which serious injury or death could result if the warning is ignored.

⚠ CAUTION: Indicates a situation in which bodily injury or damage to the vehicle could result if the caution is ignored.

- Do not modify the audio kit.
- Do not install the audio kit in any way other than described in the following instructions.
- If in any doubt, please ask your Mazda dealer to install the accessory in order to prevent errors in installation.
- If you have any questions about the use of the accessory, ask your Mazda dealer for proper advice before using it.
- Mazda and its suppliers are not responsible for injuries, accidents, and damage to persons and property that arise from the failure of the dealer or installer to follow these instructions.
- To ensure safety and reliability of the work, installation, removal and disposal work by an Authorized Mazda Dealership is recommended.
- Be careful not to lose removed parts, and be sure that they are kept free from scratches, grease or other dirt.

To the dealer

Please turn over these instructions to the customer after installation.

To the customer

- Keep these instructions after installation. The instructions may be necessary for installing other optional parts or removal of this accessory.
- Should the vehicle or this accessory be resold, always leave these instructions with it for the next owner.



1. PARTS

▼ PARTS LIST

NOTE:

- Before installation, verify that the kit includes all the following parts and that they are free of dirt, scratches, or damage.

- CG37 79 EGX (WMA-6CD unit)

Part	Part name	Qty.	Part	Part name	Qty.
	WMA-6CD Unit	1		Warranty certificate	1

2. BEFORE INSTALLATION

▼ REQUIRED TOOLS

- ☆Phillips screwdriver
- ☆Torque wrench
- ☆Tape-wrapped phillips screwdriver
- ☆Tape-wrapped fastener remover
- ☆Clean rag (soft cloth)

⚠ WARNING

- To prevent short related accidents while performing procedures, disconnect the negative battery cable before beginning any work.
- When disconnecting the connector, hold the connector itself to remove while pressing the connector lock.
- Do not apply excessive force to the wiring harness as it could cause an open circuit.
- When locking connectors, listen for a click that will indicate they are securely locked.
- Be careful not to pinch the wiring harness. Otherwise, the harness may be broken.

⚠ CAUTION

- When removing and installing vehicle parts, make sure they are clean with no scratches. Also, be sure to cover the vehicle body with protectors or mats when removing/installing parts to prevent scratches and dirt.
- When the negative battery cable is removed, the clock, radio, trip meters and other memories will be erased. Before performing work, record the content of the memory.

NOTE:

- Refer to the applicable Workshop Manual for removal and installation of vehicle parts. Not following the procedures for removal/installation in the Workshop Manual could result in an accident or vehicle malfunction.

3. VEHICLE PARTS REMOVAL

NOTE:

- The following vehicle parts removal procedure is for left-hand drive vehicles. Perform the same procedure for right-hand drive vehicles.

Negative battery cable disconnection

1. Set the selector lever to D range.
(AT vehicles only)

⚠ WARNING

- When removing/installing the parts, park the vehicle on level ground and apply the side brake securely. Be sure to turn the ignition switch off, otherwise the vehicle can move, causing personal injury or vehicle damage.

2. Disconnect the negative battery cable and wrap tape around it to insulate.

⚠ WARNING

- When the negative battery cable is connected during operation, it may cause electric shock or other personal injuries. Disconnect the negative battery cable before removal/installation.

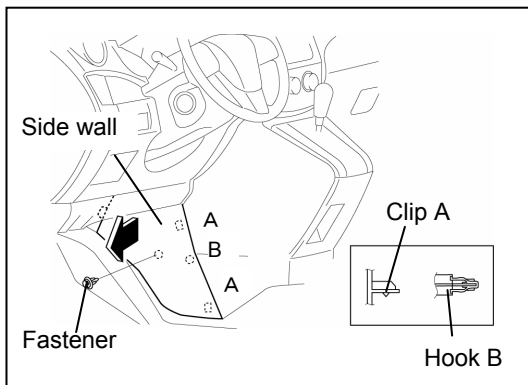

Side wall (driver's side and passenger's side) removal

1. Remove the fastener.
2. Pull the side wall in the direction of an arrow, and disengage the clips A and hook B.

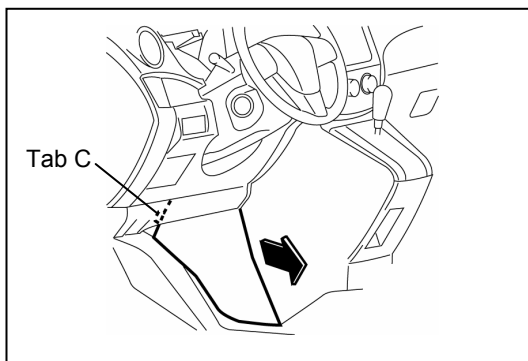

3. Pull the side wall in the direction of an arrow, disengage tab C and remove the side wall.

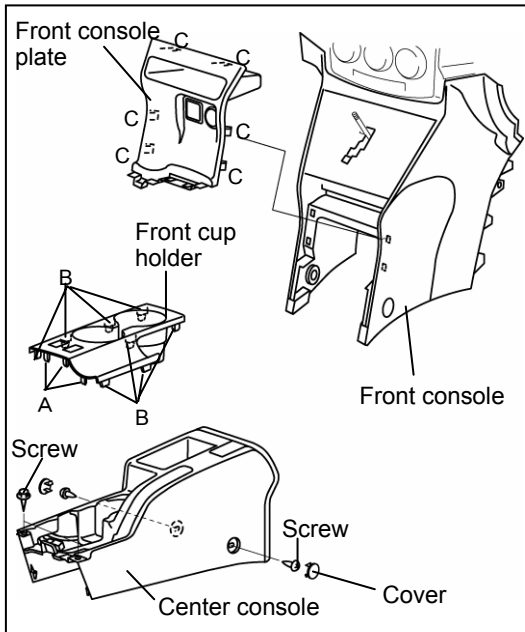

Front console removal

1. Pull the front cup holder upward and detach the tabs A (3 locations) and tabs B (8 locations) to remove the front cup holder from the center console, and disconnect the connectors.
2. Pull the front console plate outward and detach clips C (6 locations) to remove the front console plate from the front console, and disconnect the connectors.
3. Remove the screws (4), then remove the center console.

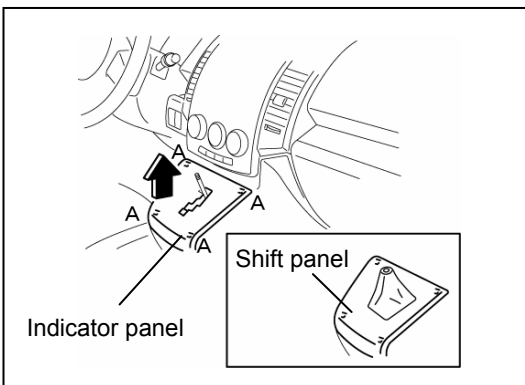

4. Remove the shift knob (MTX) or selector lever knob (ATX).
5. Detach the clips A (4 locations) to remove the shift panel (MTX) or indicator panel (ATX) from the front console.

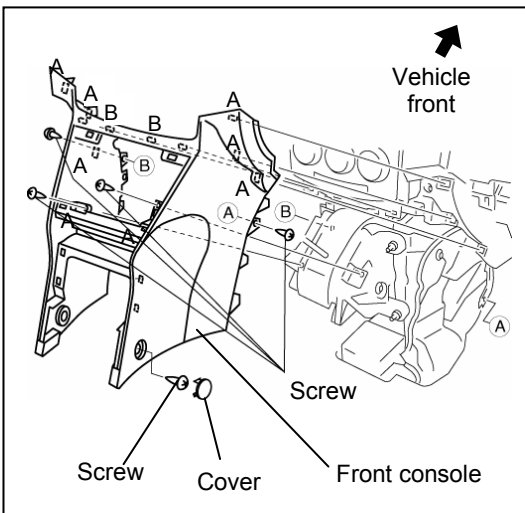

6. Remove the screws (MTX:4, ATX:6).
7. Pull the front console outward and detach clips A (6 locations) and tabs B (2 locations) to remove the front console.

⚠ CAUTION

- There are tabs B that are very difficult to access behind the face plate. Failure to properly release these tabs will result in damage to the front lower console. Use care to ensure these two tabs are released before removing the front lower console.

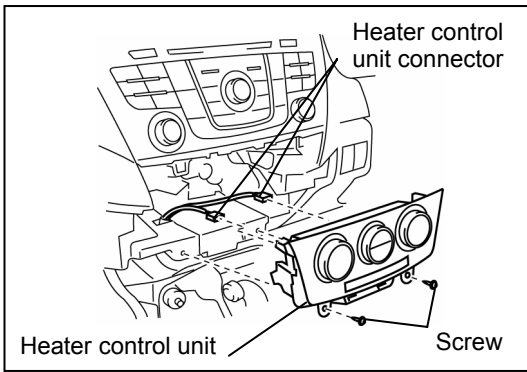

Heater control unit removal

1. Remove the screws (2).
2. Disconnect the heater control unit connectors.
3. Remove the heater control unit.

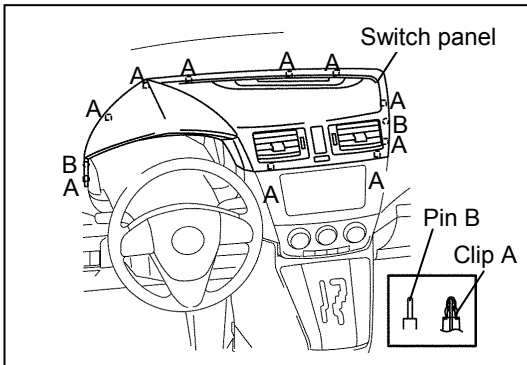

Switch panel removal

1. Pull the switch panel outward and detach clips A (10 locations) and pin B (2 locations).
2. Remove the switch panel.

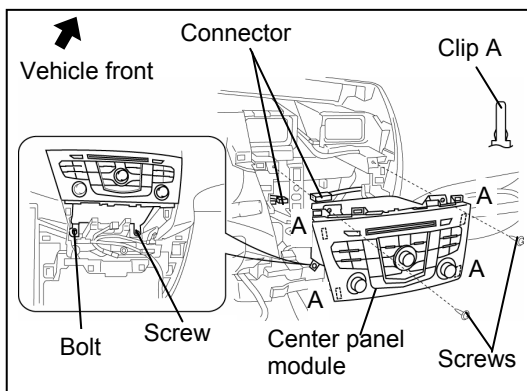

Center panel module removal

1. Remove the screws (3) and bolt (1).
2. Pull the audio unit outward and disengage clips A (4 locations).
3. Disconnect the connector and remove the center panel module.

⚠ CAUTION

- The removed center panel module is not used to install this accessory.

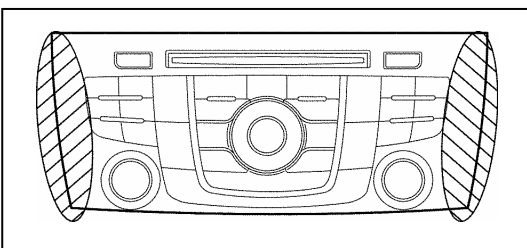

⚠ CAUTION

- When installing the center panel module, make sure that the wiring harness and antenna feeder are not caught between the module and dashboard. If the wiring harness or the antenna feeder is caught between the module and dashboard, it may cause malfunctions.
- Pressing the switch area of the audio unit when installing it could result in a malfunction. Therefore only press the hatched area shown in the figure.

4. AUDIO KIT INSTALLATION

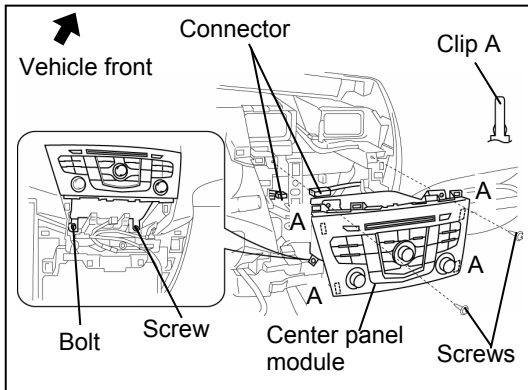

1. Connect the connectors.
2. Install the audio kit (center panel module) to the dashboard.
3. Install the screws (3) and bolt (1).

- **Bolt tightening torque:**

9 – 12 N·m {92 – 122 kgf·cm · 80 – 105 in·lbf }

5. OPERATION CHECK

1. Temporarily install the center panel module in the reverse order of removal so that an operation check can be performed.
2. Connect the negative battery cable and perform an operation check by referring to the installation and user's instructions applicable to the vehicle.
3. If there is any malfunction, disconnect the negative battery cable and verify that each connector is properly connected and the wiring harnesses are not damaged or pinched, then perform the operation check again. If it does not operate normally, contact the dealer where the unit was purchased.

If an error code appears during the operation check, refer to the applicable Workshop Manual for the vehicle and perform the repair.

⚠ CAUTION

- Do not insert CDs with labels or other objects attached. Otherwise they could become stuck in the unit.
- When the battery is disconnected, the windows will not fully open and close automatically.
Perform the following procedure to resume operation:
 1. Turn the ignition switch to the ON position.
 2. Press the switch and fully open the window.
 3. Pull up the switch and continue holding for about 2 seconds to fully close the window.
 4. If the function does not operate even after the ignition switch is turned off, contact an Authorized Mazda Dealer.

INSTALLATION INSPECTION SHEET

MAZDA5

AUDIO KIT

CG37 79 EGX

A. Vehicle parts reinstallation

- Install removed vehicle parts in the reverse order of "VEHICLE PARTS REMOVAL".

⚠ CAUTION

- Make sure that the vehicle parts are clean before reinstalling. Clean any dirty parts.
- Verify that the connectors are securely connected.

Check

--

B. Inspection after installation

- Inspect the installed / reinstalled parts for the following items.

Inspection Parts	Check Item (○)			
	Clearance/Fit	Scratches/ Dirt/ Harness interference	Installation/ Tightening/ Engagement	Operation check
Center panel module	○	○	○	○
Switch panel	○	○	○	○
Heater control unit	○	○	○	○
Front console	○	○	○	
Seat warmer switch (if equipped)		○	○	○
Side wall (driver's and passenger's side)	○	○	○	
Negative battery cable	○	○	○	
Power window auto function				○

○ : Applicable

Installation inspection sheet for Audio Kit

Date _____, _____, _____				
VIN. _____				
Approved		Checked		Person in charge

The term of validity for this sheet: 12 months