



GENUINE ACCESSORIES
INSTALLATION INSTRUCTIONS

PART NUMBER
0000-8P-R04

HOOD PROTECTOR

APPLICABLE MODEL:
2013 > CX-5

KIT CONTENTS

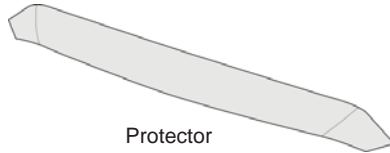
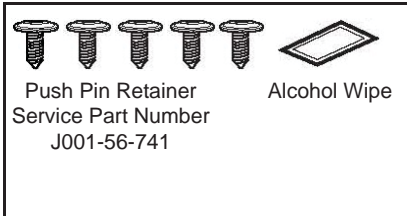

TOOLS REQUIRED



Before Installation

1. Read entire installation instruction before beginning.
2. Clean the area around vehicle hood using a mixture of 50/50 isopropyl alcohol and water.
3. It is not recommended to install this accessory over paint protection film.

1 Installation

1. Open hood and locate the plastic fasteners to be removed (Fig. 1). Use the hood protector as a guide to locate fasteners (4 locations).
2. Using the gasket removal tool, remove the fasteners. Be careful not to tear the rubber seal (Fig. 1).
3. While holding the rubber seal down, lower the hood protector onto hood aligning the holes in the tabs of the hood protector with corresponding holes in the hood (Fig. 2). Restore the rubber seal once part is aligned with the holes.

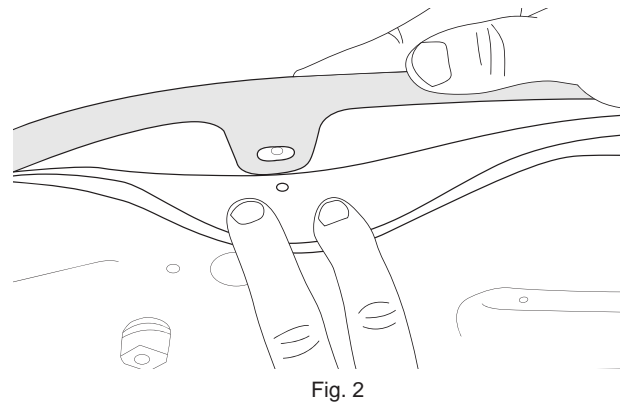
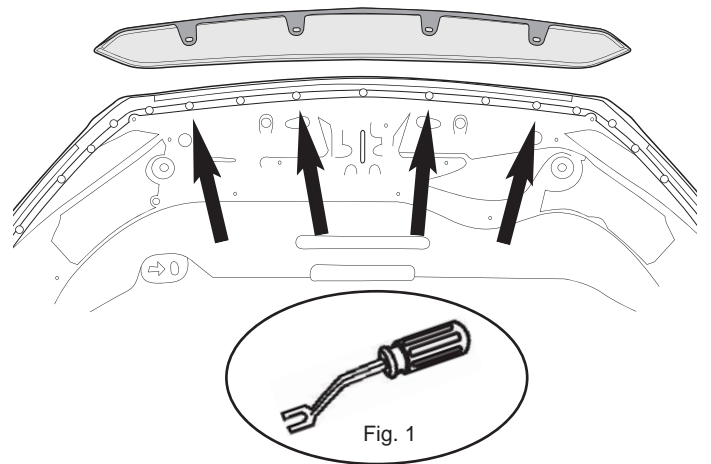

Installation (Continued)

- Using your fingers, insert the supplied Push Retainer through the rubber seal, protector, and hood (Fig. 3).

Push the fastener firmly into the hole until it is fully engaged and sits flush. (Fig. 4).

- Repeat this step for the remaining 3 holes.

PRESS FIRMLY!!

- Properly locate the protector and ensure:
 - The protector is seated in contours.
 - The protector is centered side to side.
 - The holes in the protector are aligned with holes into hood.

- Close hood.

- Locate the tape liner flag for the **lower** (leading) edge of part. (Fig. 5; Flag 1 in Fig 6) Slowly remove tape liner along the length of the part. (Fig. 6)

NOTE: For proper installation, the lower leading edge tape liner **MUST** be removed first!

The leading edge tape liner must be removed from the back of the part (trailing edge) due to the mechanical fasteners installed under the hood, (reference Fig. 3).

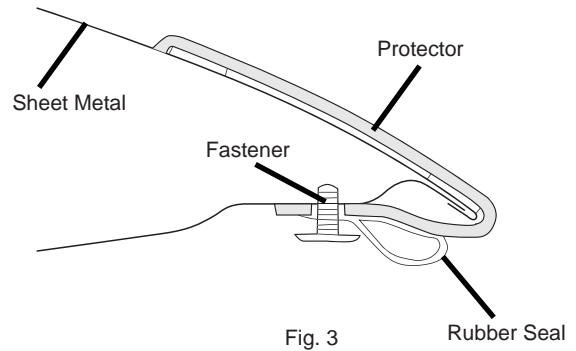

Fig. 3

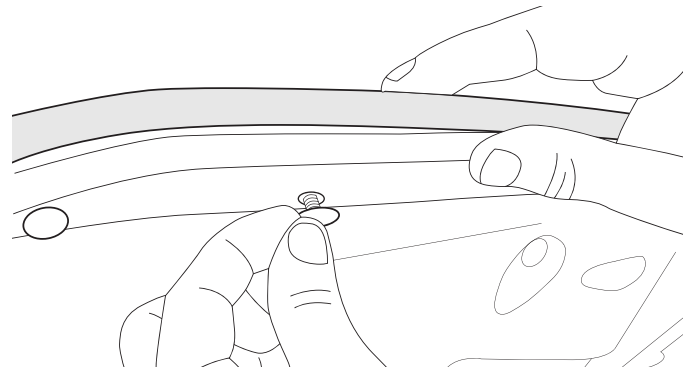

Fig. 4

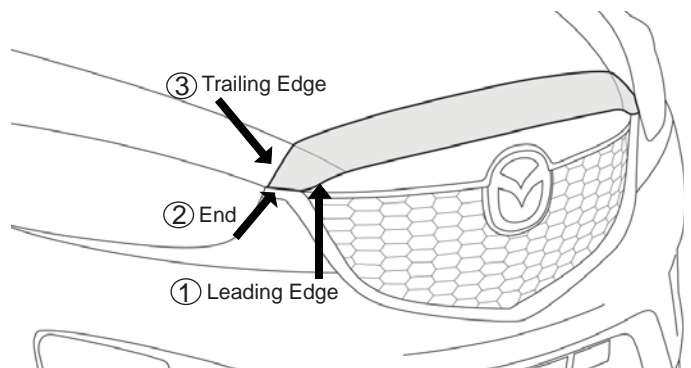

Fig. 5

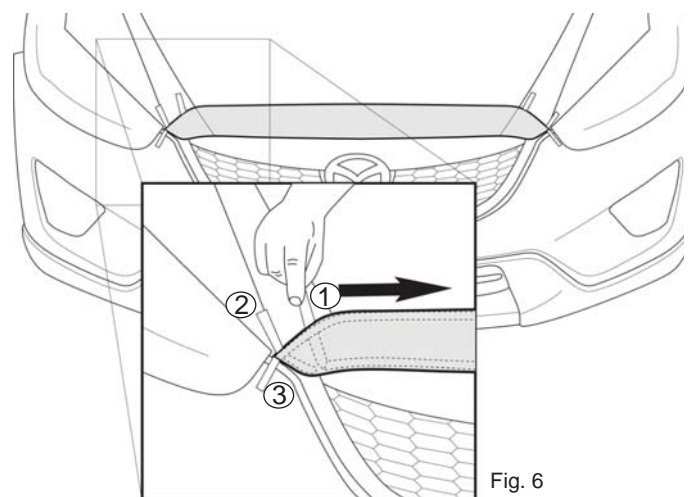
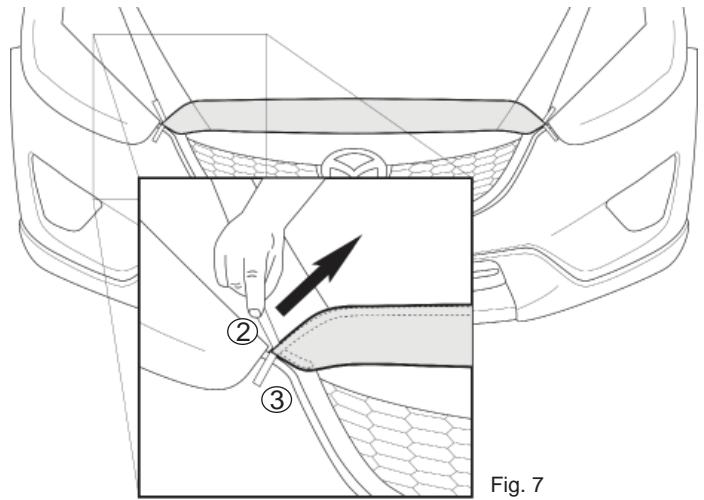

Fig. 6

Installation (Continued)

9. Locate the tape liner flag for the **end** of part. (Fig. 5; Flag 2 in Fig. 7) Slowly remove tape liner along the end of the part. (Fig. 7)



10. Locate the tape liner flag for the **upper** (trailing) edge of part. (Fig. 5; Flag 3 in Fig. 8) Slowly remove tape liner along the length of the part. (Fig. 8)

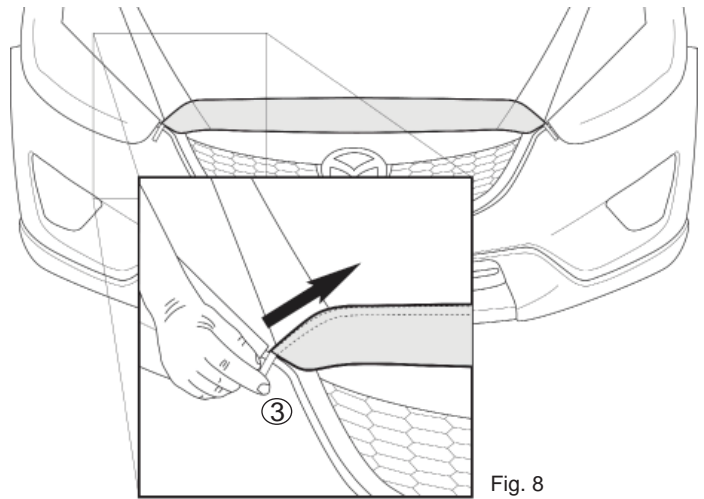

11. Apply 30 PSI downward pressure for 10 seconds to all taped areas for proper bond. Tape reaches maximum bond after 24 hours of contact (Fig. 9).

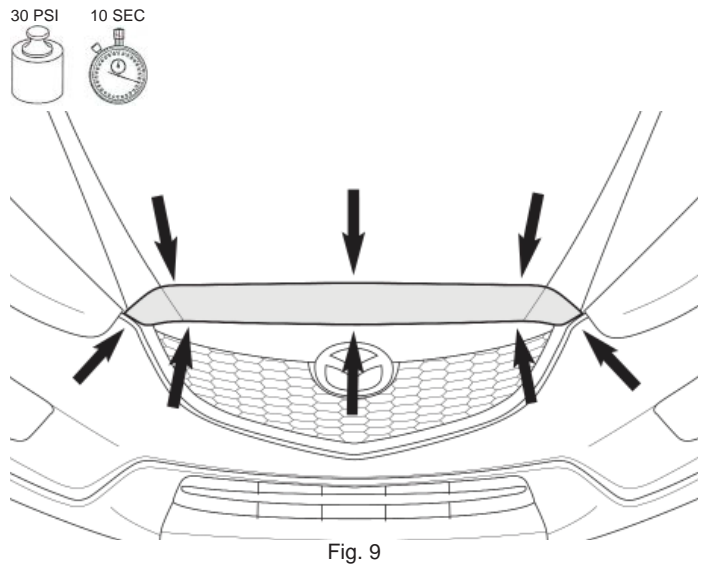

Installation (Continued)

12. Provide installation instructions to customer.

13. **Do not wash car in automatic car wash for 24 hours.**

2 Cleaning Instructions

Use mild soap to clean the hood deflector. Do not use ammonia or glass cleaners containing ammonia. This will damage the surface finish on the protector.

NOTE: To minimize the potential of color fade between the area of the protector and the rest of the hood, vehicle should be waxed at least twice per year.