

GENUINE Parking Sensor

INSTALLATION INSTRUCTIONS



Thank you for purchasing a genuine Mazda accessory.

Before removal and installation, be sure to thoroughly read these instructions.

Please read the contents of this booklet in order to properly install and use the Parking sensor. Your safety depends on it.

Keep these instructions with your vehicle records for future reference.

WARNING

- There are several  **WARNING** and  **CAUTION** sections in this booklet concerning safely when installing or removing the Parking sensor. Always read and follow them in order to prevent injuries, accidents, and possible damage to the vehicle.

 **WARNING:** Indicates a situation in which serious injury or death could result if the warning is ignored.

 **CAUTION:** Indicates a situation in which bodily injury or damage to the vehicle could result if the caution is ignored.

- For areas indicating the tightening torque in this instruction manual, tighten to the specified torque using a torque wrench.
- Do not modify the Parking sensor.
- Do not install the Parking sensor in any way other than described in the following instructions.
- If in any doubt, please ask your Mazda dealer to install the accessory in order to prevent errors in installation.
- If you have any questions about the use of the accessory, ask your Mazda dealer for proper advice before using it.
- Mazda and its suppliers are not responsible for injuries, accidents, and damage to persons and property that arise from the failure of the dealer or installer to follow these instructions.
- To ensure safety and reliability of the work, installation, removal and disposal work must be carried out by an Authorized Mazda Dealership.
- Be careful not to lose removed parts, and be sure that they are kept free from scratches, grease or other dirt.

PART NAME:	Parking sensor
VEHICLE:	MAZDA CX-5
PART NUMBER:	C851 V7 290 (Parking sensor kit) KD33 V7 282 (Optional ON-OFF switch)

NOTE

To the dealer

- Please turn over these instructions to the customer after installation.

To the customer

- Keep these instructions after installation. The instructions may be necessary for installing other optional parts or removal of this accessory.
- Should the vehicle or this accessory be resold, always leave these instructions with it for the next owner.

1. PARTS

▼ Installation view

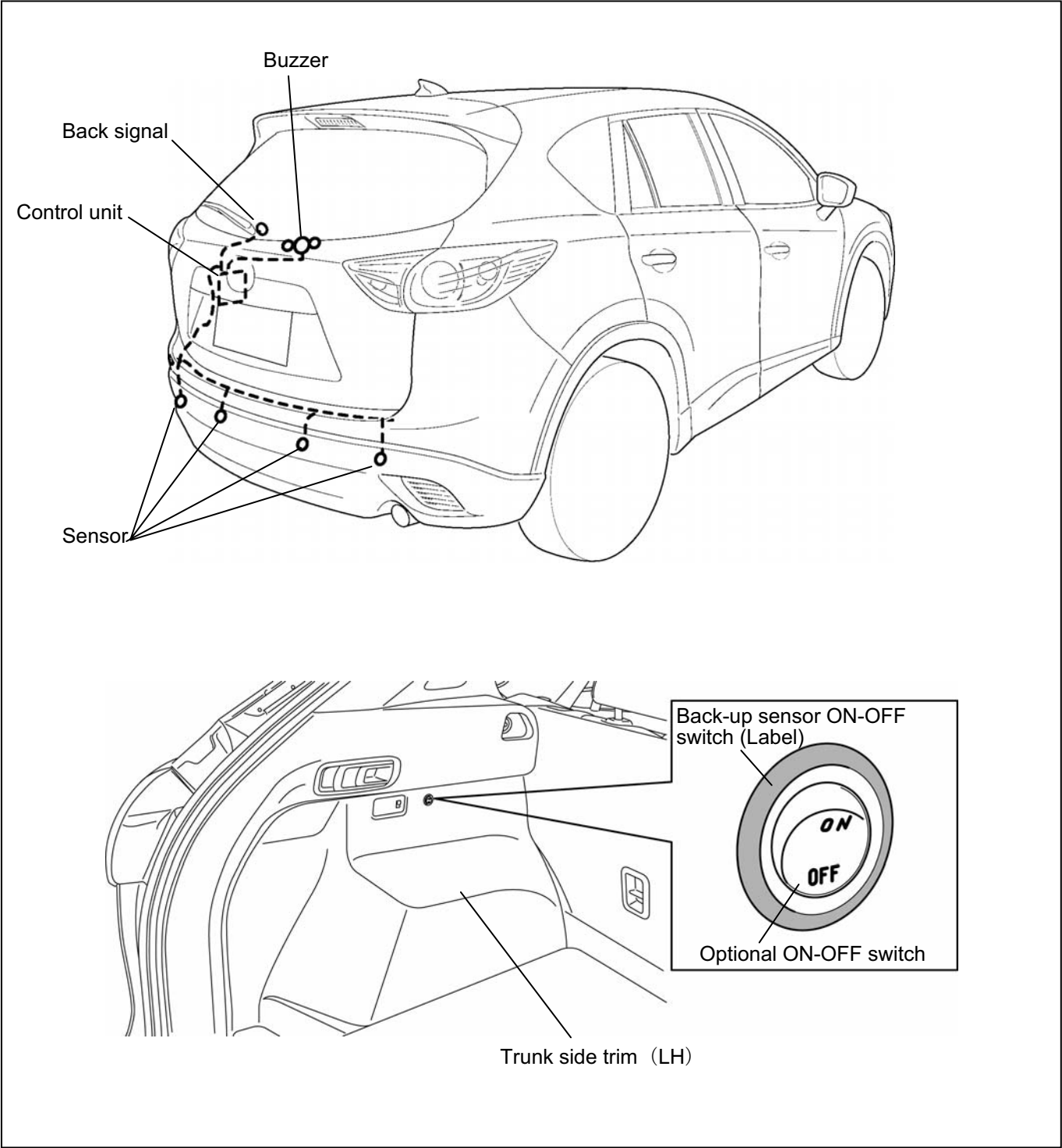











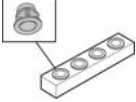

▼ Parts list



Note

- Verify that the kit includes all the following parts and that the parts are not dirty, scratched, or damaged.

C851 V7 290 (Parking sensor kit)

Part	Part name	Qty.	Part	Part name	Qty.	Part	Part name	Qty.
	Control unit (C850 V7 288)	1		Buzzer	1		Main harness	1
	Sensor	4		Electro tap	1		Mount base	8
	Harness (short) (For sensor No.3,4)	1		Harness (long) (For sensor No.1,2)	1		Tie wrap	15
	Double-sided adhesive tape	1		Double-sided adhesive tape	1		Washer	4
	Installation instructions	1		Installation inspection sheet	1			

KD33-V7-282 (Optional ON-OFF switch)



Part	Part name	Qty.	Part	Part name	Qty.	Part	Part name	Qty.
	Optional ON-OFF switch	1		Harness (With electro taps)	1		Back-up sensor ON-OFF switch (Label)	1

2. BEFORE INSTALLATION



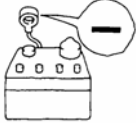

■ REQUIRED TOOLS

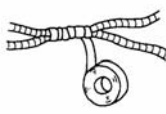
☆Screwdriver (Flathead) ☆Screwdriver (Phillips) ☆Socket wrench ☆Fastener remover ☆Nipper
 ☆Pliers ☆Masking tape ☆Electrical vinyl tape ☆Mat ☆IPA (Isopropyl alcohol)
 ☆Drill (2 mm) ☆Punch ☆Holesaw(20 mm) ☆File ☆Utility knife

⚠ WARNING

When the negative battery cable is connected during operation, it may cause electric shock or other personal injuries. Disconnect the negative battery cable before removal/installation.	When connecting/disconnecting connectors, grasp the connectors, not the wires. Otherwise a short, an accident from poor contact or fire may occur.	Do not pull the harness with excessive force. Doing so can cause a breakage or a short-related accident, as well as an electrical short or fire.	Secure the harness with the band (part included) so it doesn't dangle. If not, it may cause a short, accident, or fire.
			

⚠ CAUTION

Using improper tools may cause damage and or broken parts. Use the correct tool for the job.	Wrap protective tape around screwdrivers and fastener remover tools to prevent scratching the vehicle.	Excessive length of tie wrap may interfere with other parts and cause damage. Cut unnecessary part up to about 5 mm {0.19 in} from the fixed point.	Put the removed parts and the parts in the kit on the protective sheet to prevent scratches.
			

⚠ WARNING

- When removing/installing the parts, park the vehicle on level ground and apply the side brake securely. Be sure to turn the ignition switch off, otherwise the vehicle can move, causing personal injury or vehicle damage.

Note

- When the negative battery cable is removed, the clock, radio, trip meters and other memories will be erased. Before performing work, record the content of the memory.
- Refer to the Workshop Manual for removal and installation of vehicle parts. Not following the procedures for removal/installation in the Workshop Manual could result in an accident or vehicle malfunction.

3. CONNECTION DIAGRAM

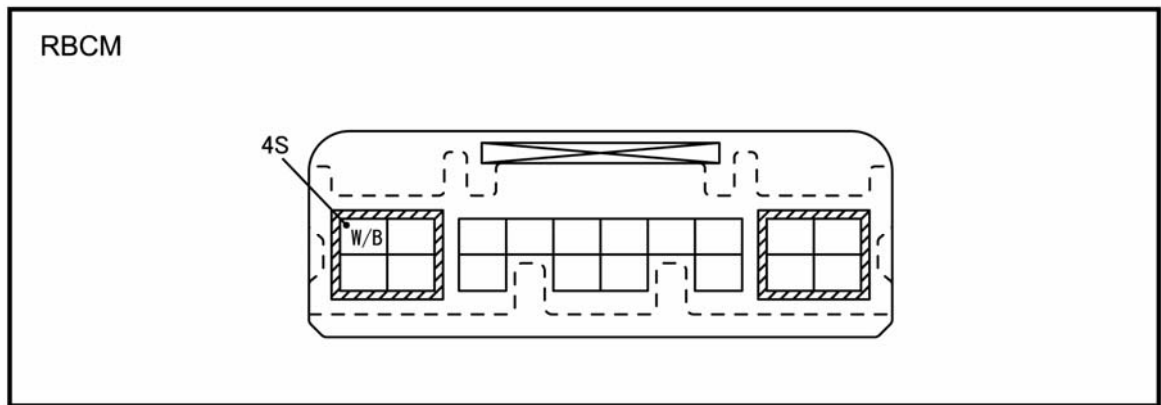
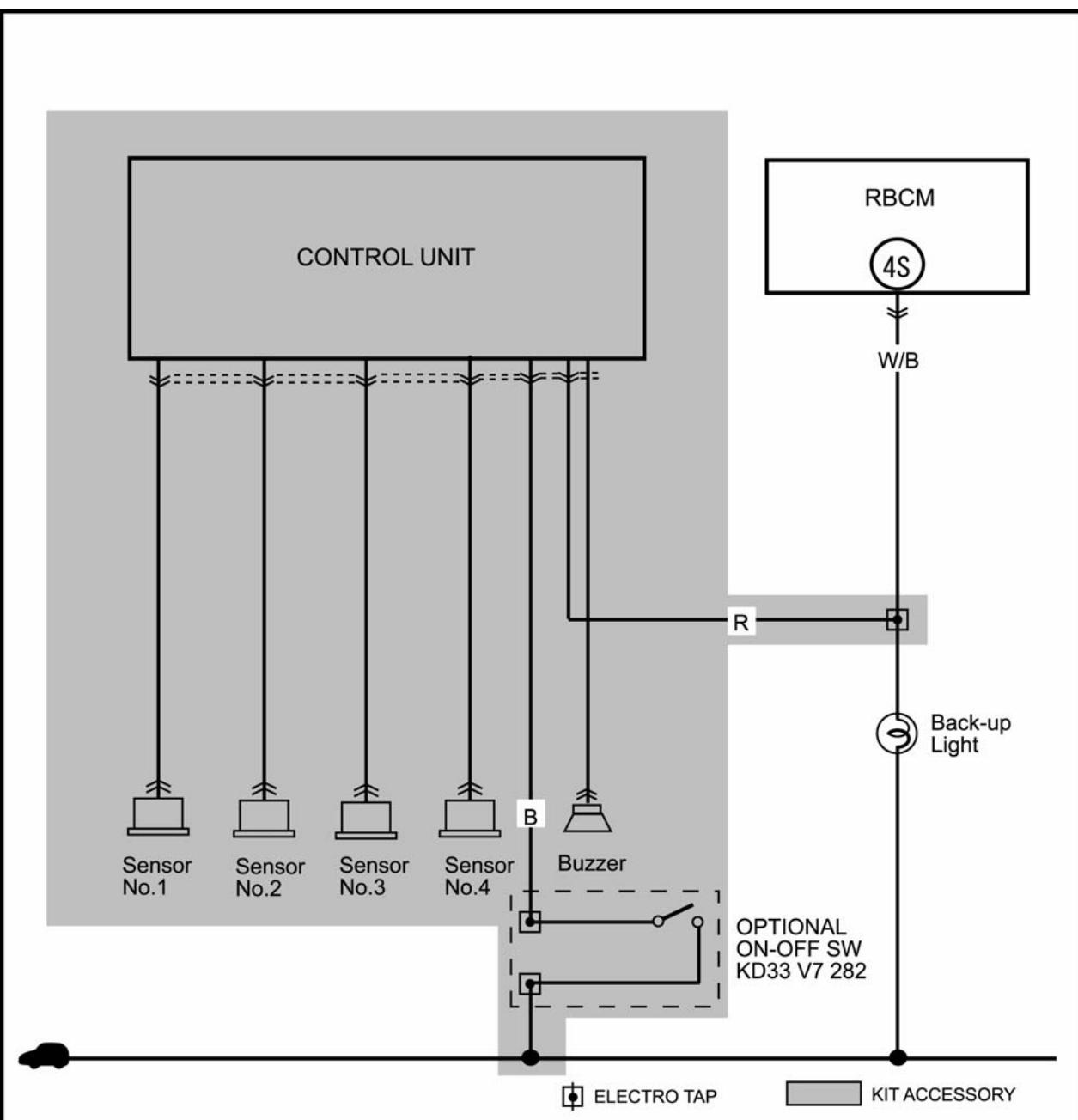

4. BEFORE INSTALLATION

■ Sensor installation position marking (rear bumper)

⚠ CAUTION

- Mark the drilling position for the rear bumper before removing the vehicle parts.

1. Open the liftgate.
2. Set the selector lever to P range.
3. Disconnect the negative battery cable. (Refer to 8 page.)
4. Punch a drill guide mark in the center of the hole drilling position (4 locations) using a punch.

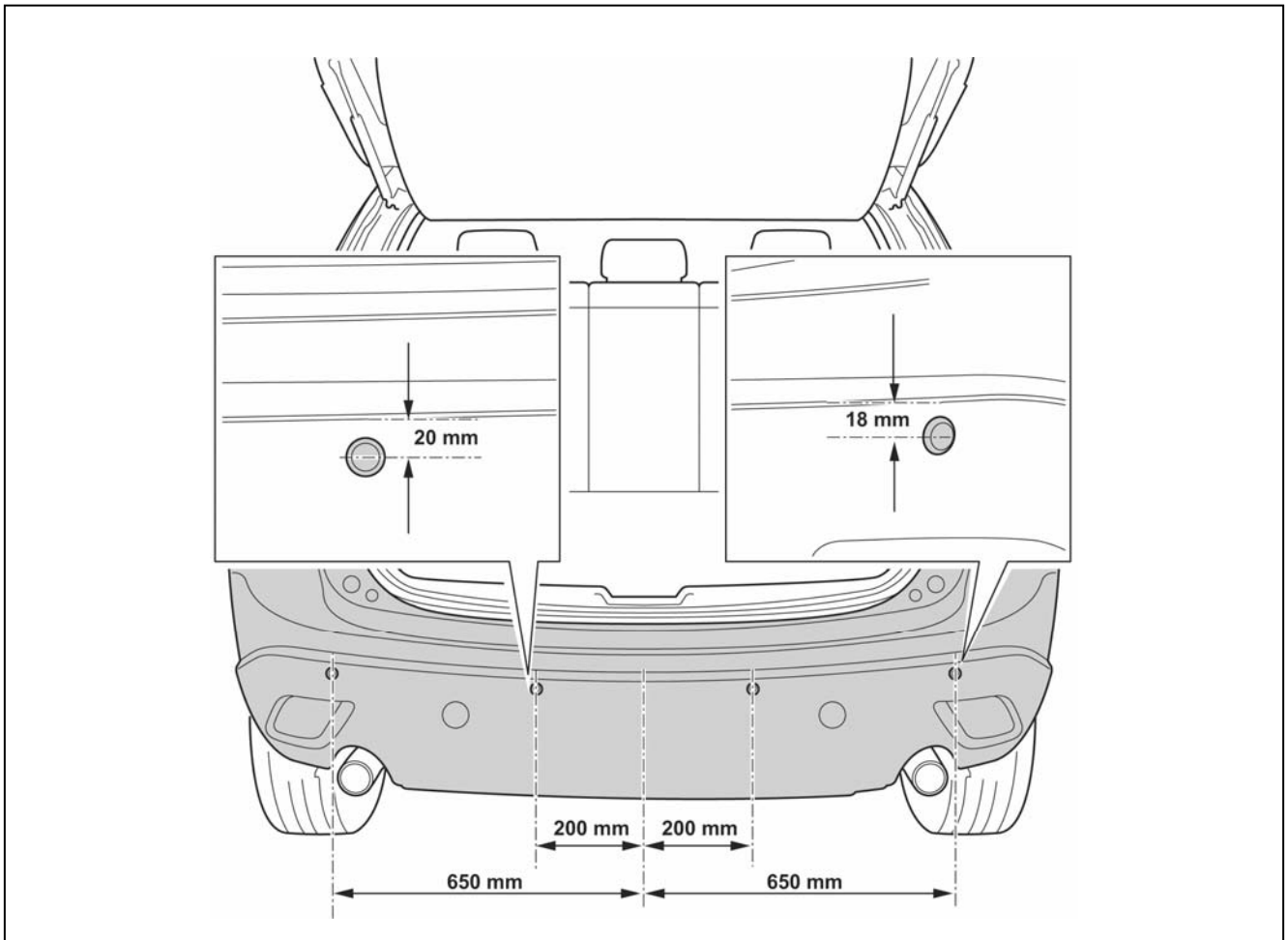

■ Optional ON-OFF switch installation position marking (trunk side trim (LH))

⚠ CAUTION

- Mark the drilling position for the trunk side trim (LH) before removing the vehicle parts.

1. Open the liftgate.
2. Set the selector lever to P range.
3. Disconnect the negative battery cable. (Refer to 8 page.)
4. Punch a drill guide mark in the center of the hole drilling position (2 locations) using a punch.

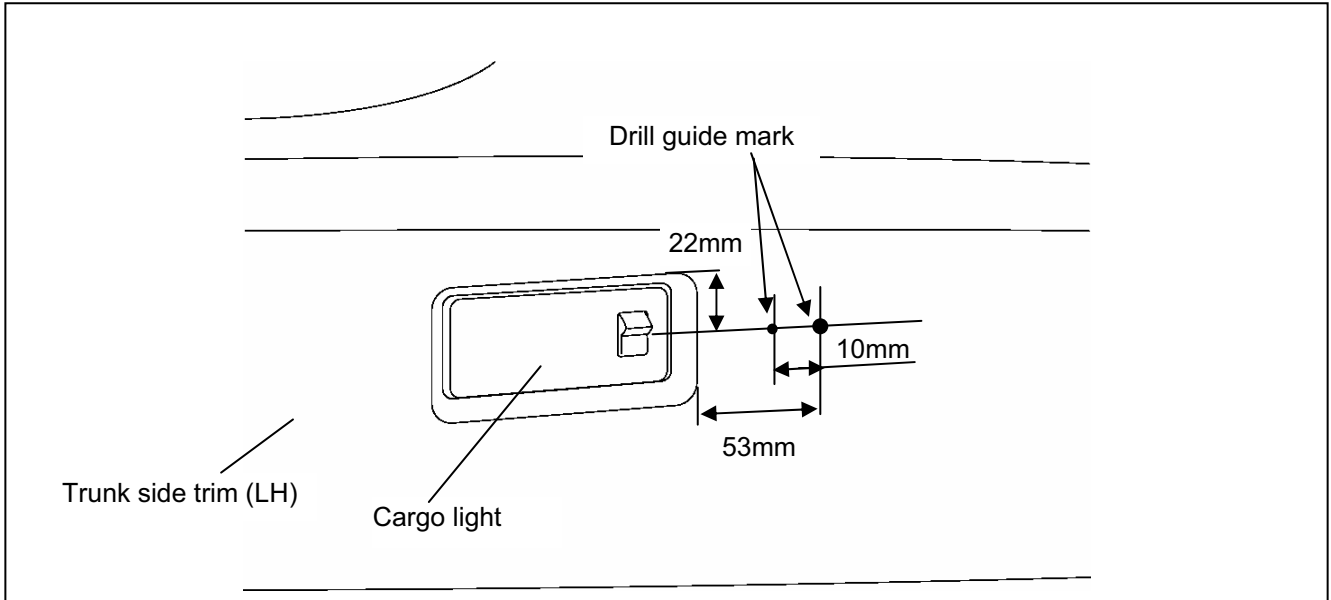

5. VEHICLE PART REMOVAL

⚠ CAUTION

- Be careful not to damage or lose any parts removed from the vehicle since they will be reused.

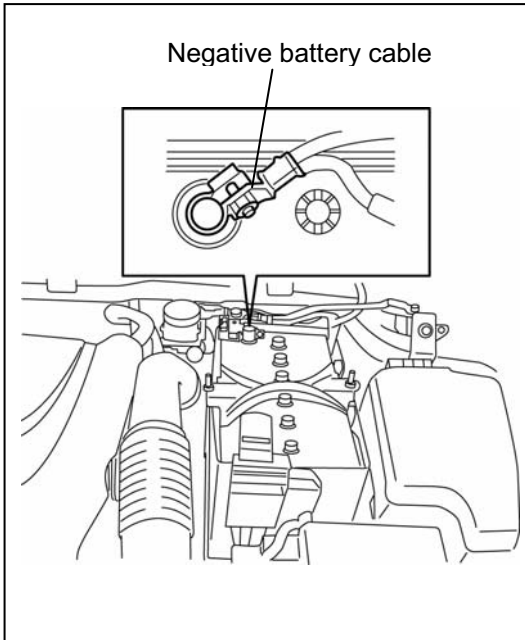

Negative battery cable disconnection

1. Set the selector lever to P range.
(AT vehicles only)

⚠ WARNING

- When removing/installing the parts, park the vehicle on level ground and apply the side brake securely. Be sure to turn the ignition switch off, otherwise the vehicle can move, causing personal injury or vehicle damage.

2. Disconnect the negative battery cable and wrap tape around it to insulate.

⚠ WARNING

- When the negative battery cable is connected during operation, it may cause electric shock or other personal injuries. Disconnect the negative battery cable before removal/installation.

Tightening torque : 4.0-6.0 N·m

Cover assy-tonneau removal (if equipped)

1. Remove the holder on the left end of the cover assy-tonneau into the mounting hole of the trunk side trim.

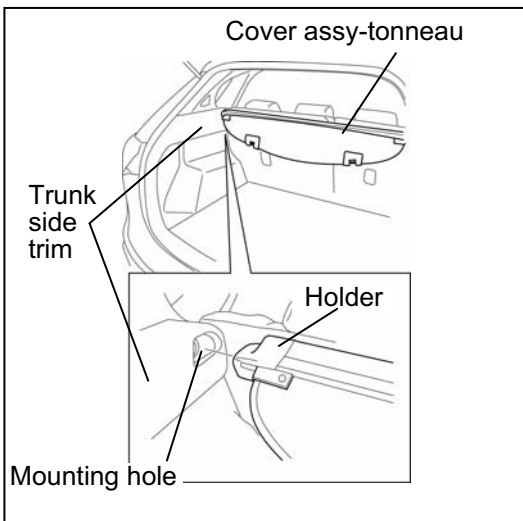

2. Retract the holder on the right end of the cover assy-tonneau and remove it into the mounting hole.

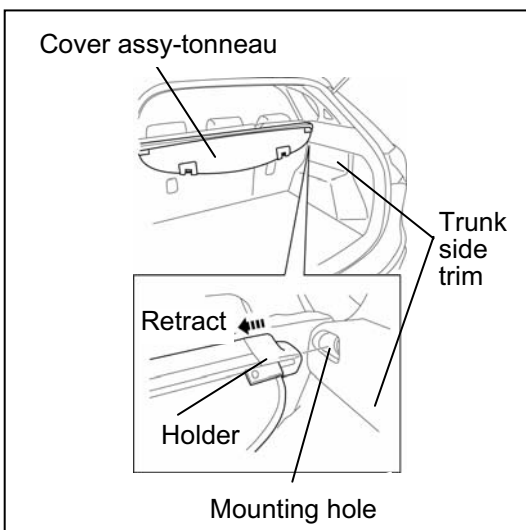

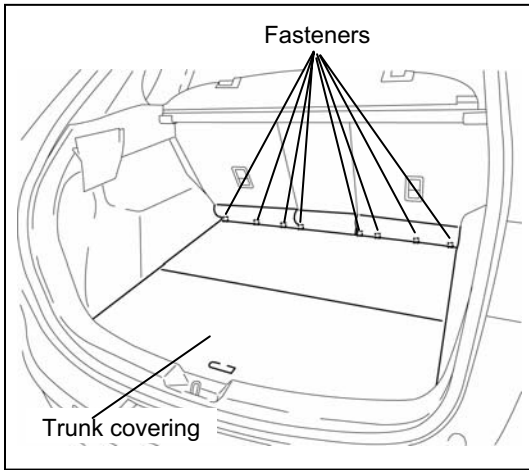

Trunk covering removal

1. Remove fasteners.
2. Remove the trunk covering.

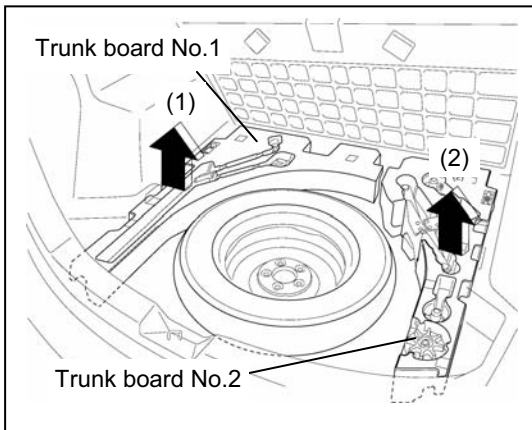

Trunk board removal

1. Set the trunk covering aside.
2. Remove the trunk board No.1 in the direction of the arrow (1) shown in the figure.
3. Remove the trunk board No.2 in the direction of the arrow (2) shown in the figure.

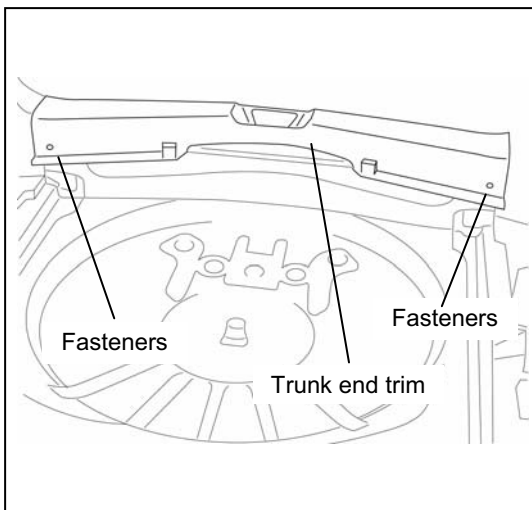

Trunk end trim removal

1. Partially peel back the liftgate weather strip.
2. Remove fasteners.

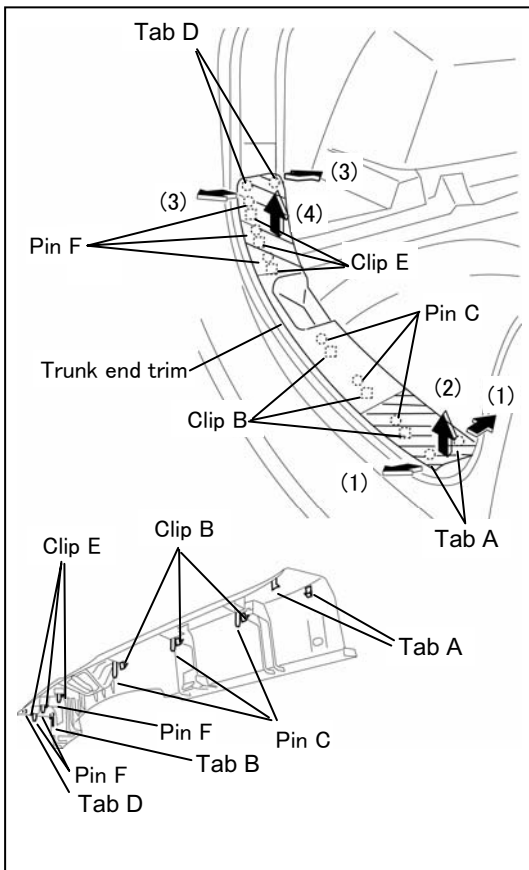

3. Take the shaded area shown in the figure, detach tabs A while pulling the trunk end trim in the direction of the arrow (1) shown in the figure, then detach clips B, pins C while pulling in the direction of the arrow (2).
4. Take the shaded area shown in the figure, detach tabs D while pulling the trunk end trim in the direction of the arrow (3) shown in the figure, then detach clips E, pins F while pulling in the direction of the arrow (4).

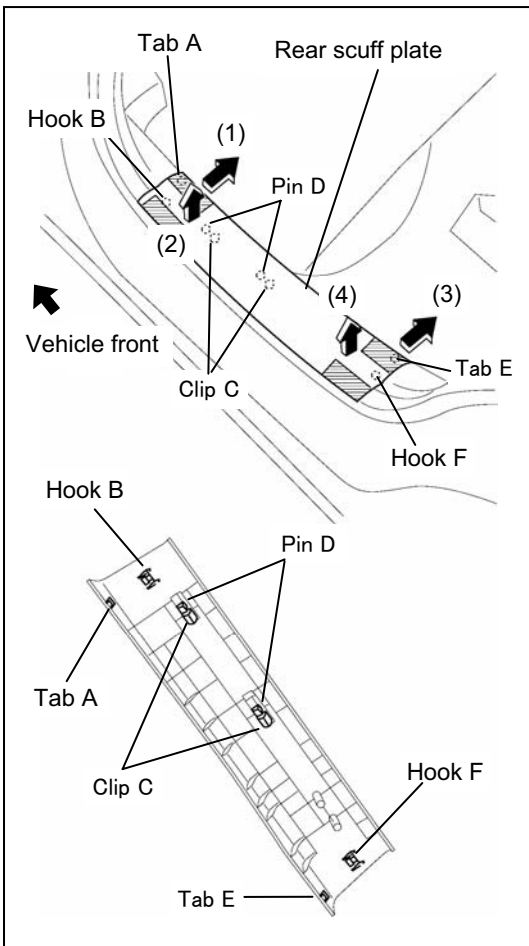

Rear scuff plate removal (Driver's side)

1. Take the shaded area shown in the figure, detach tab A while pulling the rear scuff plate in the direction of the arrow (1) shown in the figure, then detach hook B, clips C, pins D while pulling in the direction of the arrow (2).
2. Take the shaded area shown in the figure, detach tab E while pulling the rear scuff plate in the direction of the arrow (3) shown in the figure, then detach the hook F while pulling in the direction of the arrow (4).

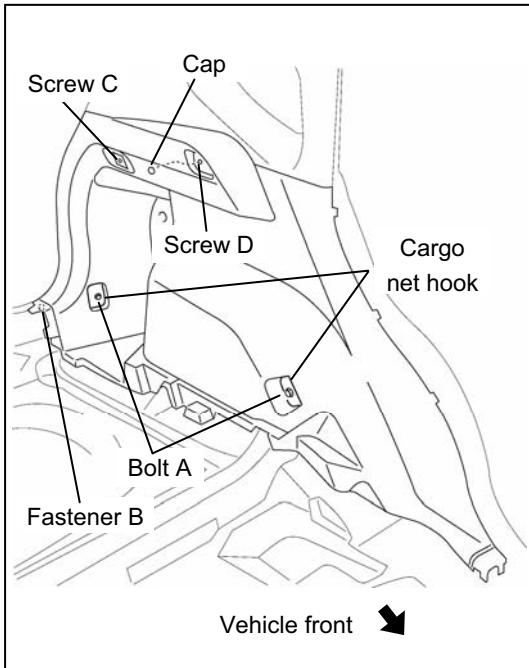

Trunk side trim (LH) removal

1. Remove bolts A, then remove the cargo net hook.

Tightening torque : 0.9-1.3 N·m

2. Remove the fastener B.

3. Remove the screw C.

4. Remove the cap, then remove the screw D. (4:2:4 split type)

5. Hold D-pillar trim with your hands and pull the trunk side trim in the direction of the arrow (1), (2), (3), (4) and remove clips E, hooks F and pin G.

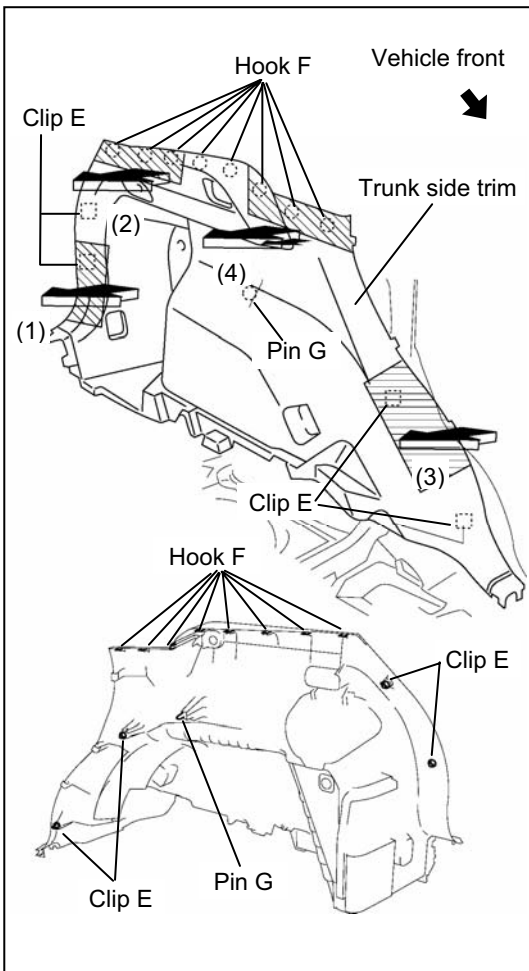

6. Set the remote handle lever out of the way. (4:2:4 split type)

7. Disconnect the connector. (Cargo room light connector, rear accessory socket connector)

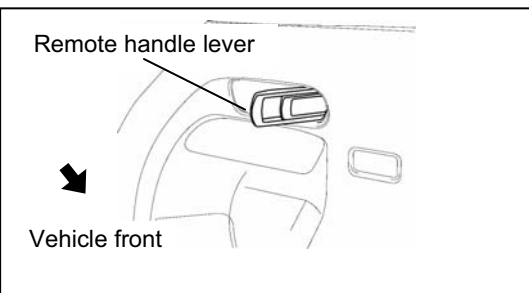

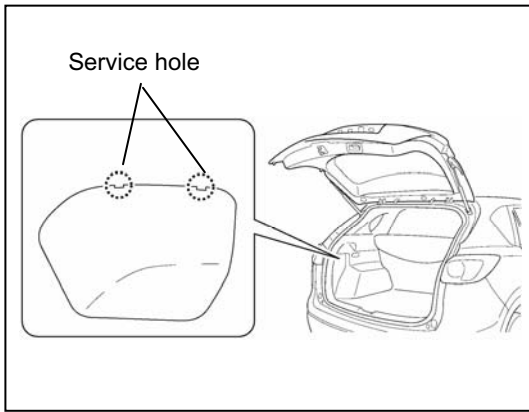

Rear combination light removal

- Fogging or condensation on the inside of the rear combination lights may occur due to a natural phenomenon occurring as a result of a temperature difference between the interior and exterior of the combination lights. However, it has no effect on the light performance because the temperature inside the rear combination lights rises after illuminating the brake/taillight bulbs or a period of time has elapsed.

1. Insert a tape-wrapped flathead screwdriver into the service hole in the position shown in the figure.
2. Move the flathead screwdriver in the direction of the arrow (1) shown in the figure, pull out the service hole cover, and detach the service hole cover tab and trunk side trim.

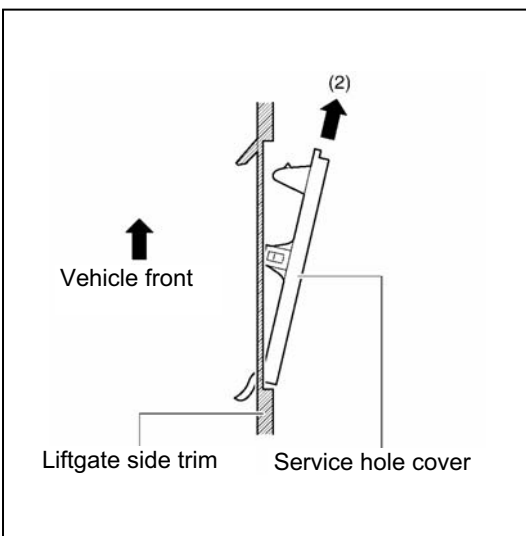
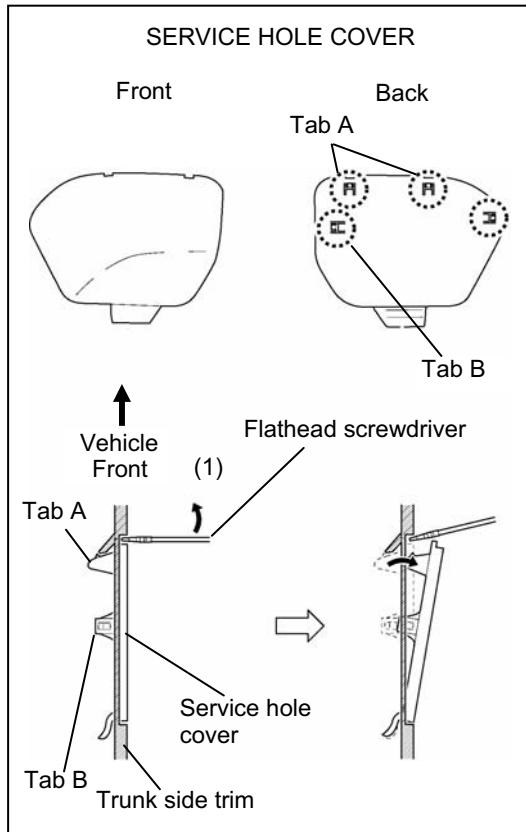

3. Pull out the service hole cover in the direction of the arrow (2) shown in the figure and pull out the service hole cover hook from the trunk side trim.
4. Remove the service hole cover.

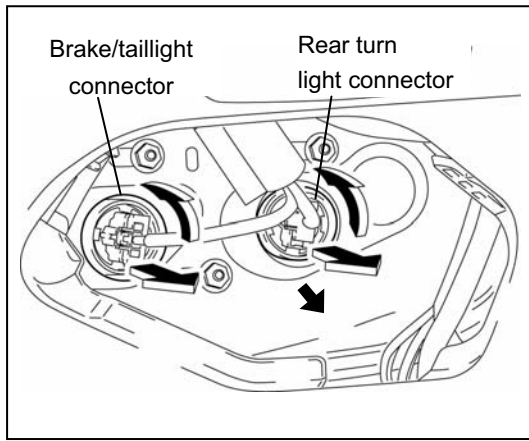

5. Disconnect the connectors.

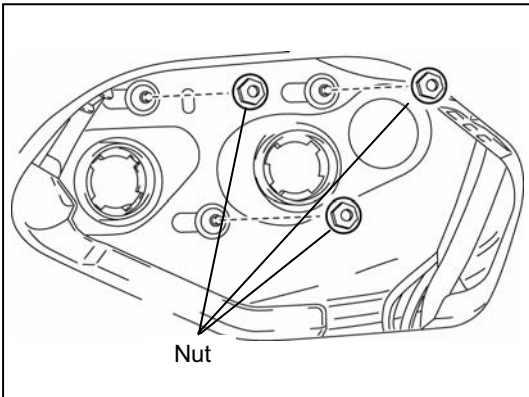

6. Remove the nuts.

Tightening torque : 4.1-6.1 N·m

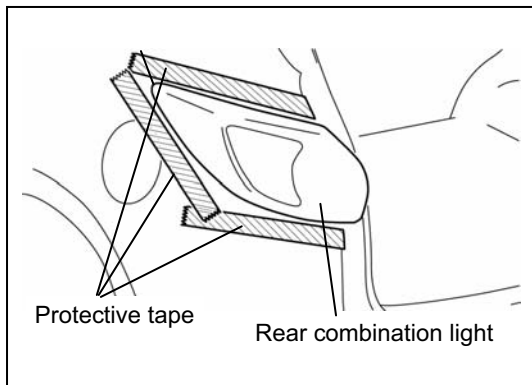

7. To prevent scratches or damage, affix protective tape to the position shown in the figure.

⚠ CAUTION

- When the rear combination light is removed from the body, perform the procedure after affixing protective tape to the body. Otherwise, the body could interfere with the rear combination light and cause scratching or damage to the body.

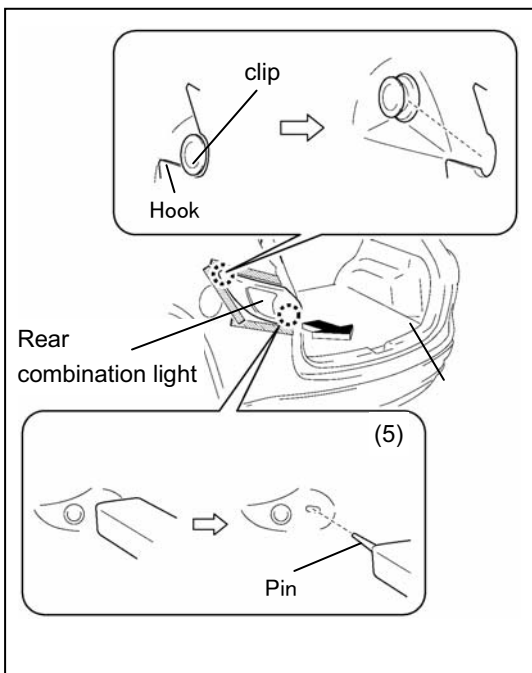

8. Pull the rear combination light in the direction of the arrow (5) shown in the figure and remove the rear combination light hook from the clip.

9. Pull out the rear combination light pin.

10. Remove the rear combination light.

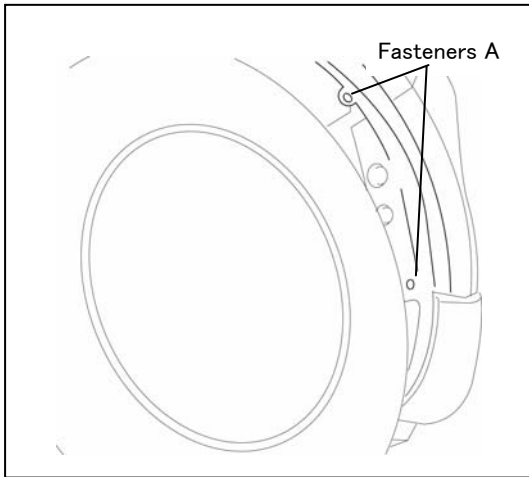

Rear over fender removal

1. Remove fasteners A.

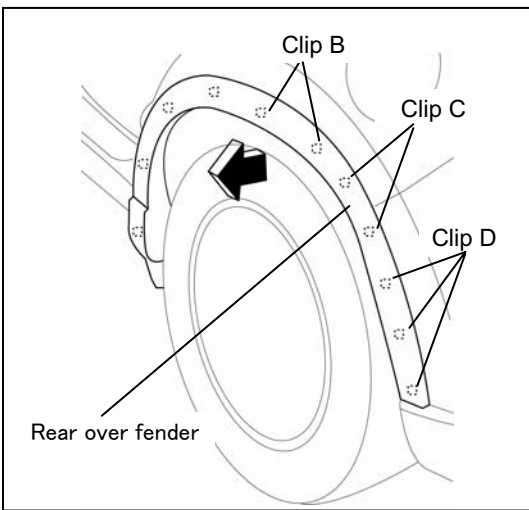

2. Pull the rear over fender in the direction of the arrow while removing clips B, C, D.

⚠ CAUTION

- Do not pull over fender far from vehicle as it may cause stress damage around clip B area.

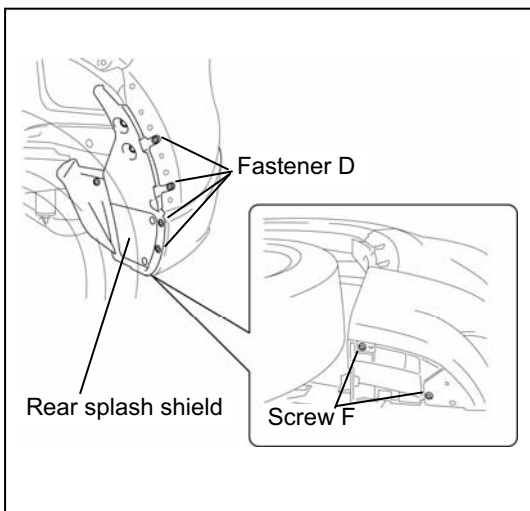

Rear splash shield removal

1. Set the rear over fender aside.
2. Remove screw D.
3. Remove screw F.
4. Remove in the rear splash shield.

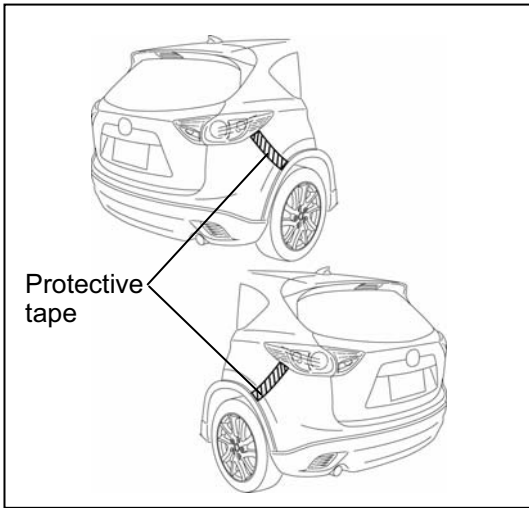

Rear bumper removal

1. Affix the protective tape to the position (body side) shown in the figure.

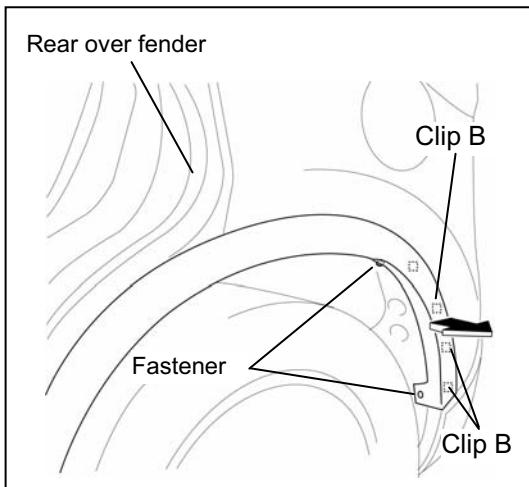

2. Remove fasteners A.

3. Pull the rear over fender in the direction of the arrow shown in the figure above, then peel it back while removing clips B.

⚠ CAUTION

- After removing clips B, insert a rag between the rear fender panel and the rear over fender to prevent the rear fender panel and clips B from being damaged.

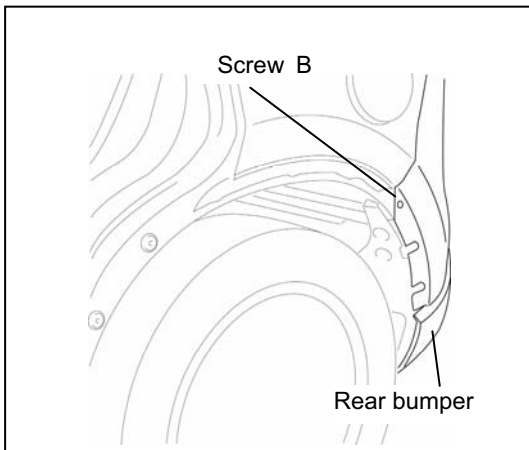

4. Remove screw B.

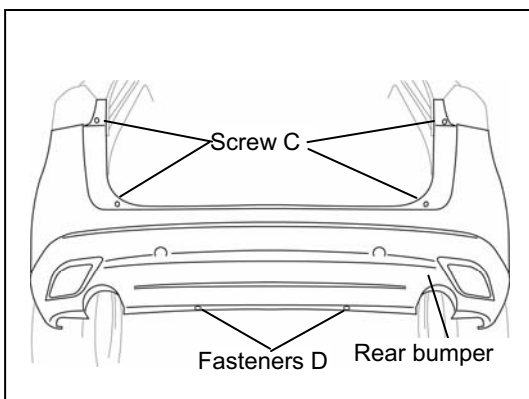

5. Remove screws C.

6. Remove fasteners D.

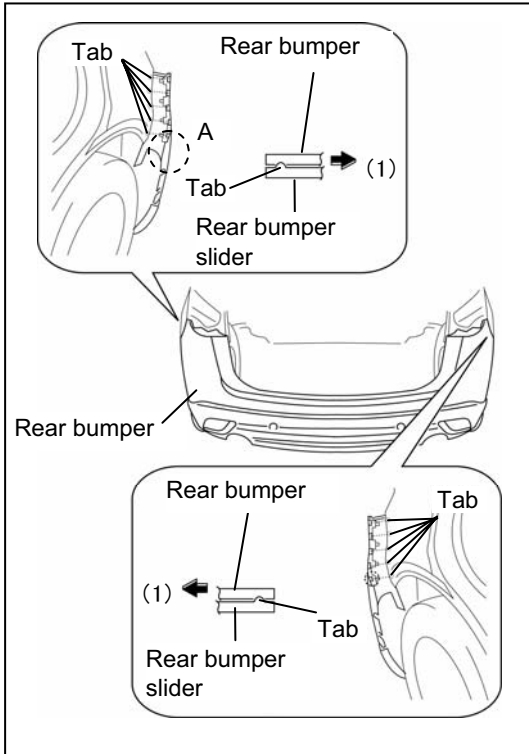

7. Pull the end of the rear bumper (A) in the direction of the arrow (1) shown in the figure, while removing tabs.

⚠ CAUTION

- The rear bumper and rear bumper slider are engaged firmly. If they are disengaged forcibly the bumper could fall and be damaged. Perform the servicing carefully when disengaging the rear bumper from the rear bumper slider.
- When disengaging the rear bumper from the rear bumper slider, the rear bumper could fall and be damaged. Support the front of the rear bumper so that it does not fall.

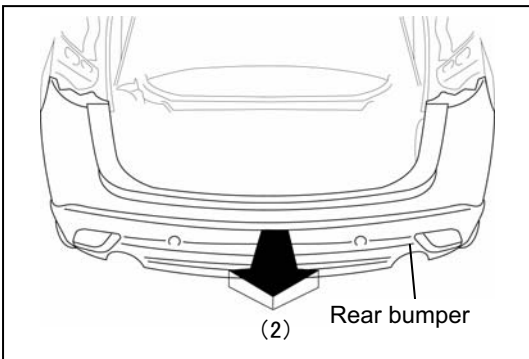

8. Remove the rear bumper from rear bumper slider.

9. Remove the rear bumper in the direction of the arrow (2) shown in the figure.

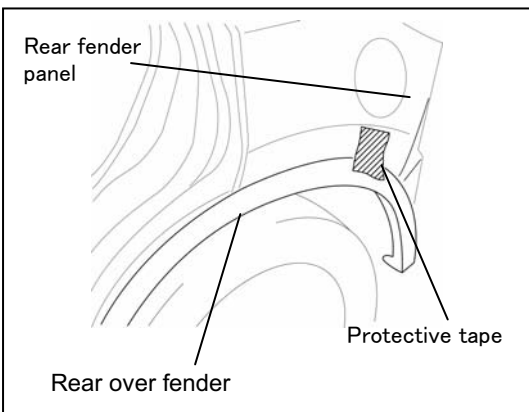

10. Fix the rear over fender to the rear fender panel with protective tape to prevent loose part from damage.

⚠ CAUTION

- After removing rear bumper, it may hit the rear over fender and cause a damage and/or injury. Always perform Step 10.

6. INSTALLATION OF SENSOR, ON-OFF SWITCH, BUZZER, AND UNIT

■ Sensor installation

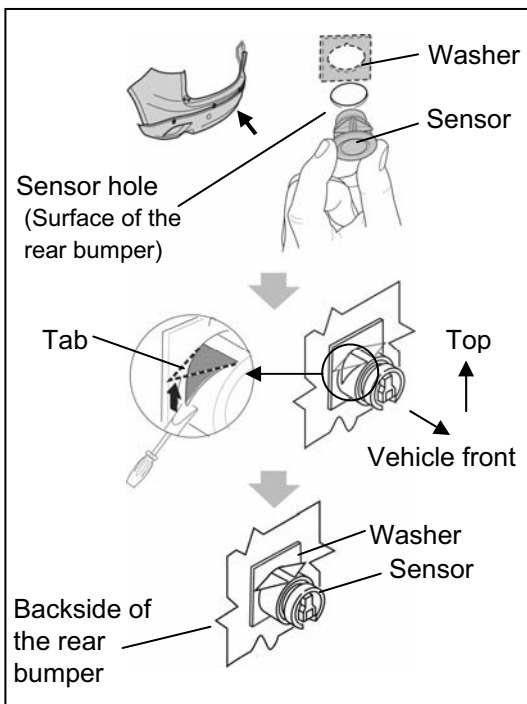
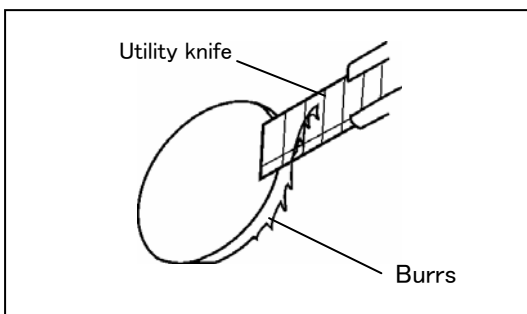
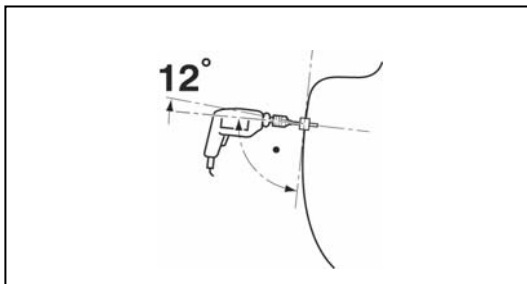
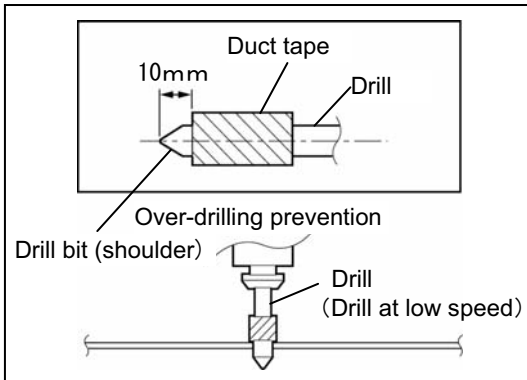

1. Wrap the drill bit with duct tape as shown in the figure.
2. Set the drill rotation to low speed.

⚠ CAUTION

- Always use a drill with a rotation speed adjustment, otherwise the rear bumper may deform.
- Be careful when handling drills and other sharp objects.
- To prevent scratching and over-drilling, always wrap the drill bit with duct tape.

3. Drill four 2 mm diam. holes in the 4 marked positions using a drill with the drill bit pointed at a angle of 0 to 12 degrees to the bumper.
4. Drill a 20 mm diam. hole from the center of the sensor hole using a hole saw.

⚠ WARNING

- Be careful when handling drills and other sharp objects. If not handled properly, it could result in serious injury.

5. Remove burrs from the drilled holes using a utility knife.

⚠ CAUTION

- If the sensor is installed forcibly while the hole is small, it could deform the bumper.
- Make sure to remove burrs from the surface so that the bumper surface is smooth.

6. Hold the outside of the round part of the back sensor and insert the sensor into the hole slowly.
7. After inserting the washer into the sensor from the backside of the bumper, press the sensor into the bumper and secure it.
8. Pull up the sensor tab using a flathead screwdriver.

⚠ CAUTION

- Insert the sensor so that the sensor tab is facing upward.
- After installation, verify that the corner sensor and back sensor are securely pressed to the bumper.

■ Optional ON-OFF switch installation (KD33-V7-282)

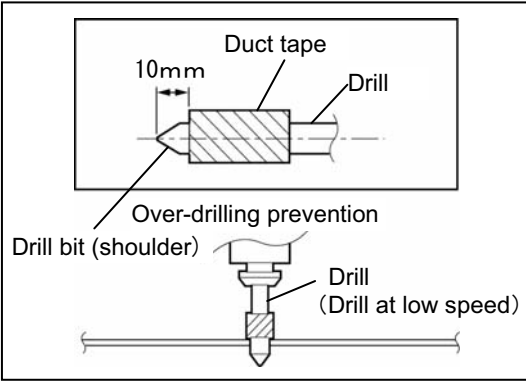

1. Wrap the drill bit with duct tape as shown in the figure.
2. Set the drill rotation to low speed.

⚠ CAUTION

- Always use a drill with a rotation speed adjustment, otherwise the trunk side trim may deform.
- Be careful when handling drills and other sharp objects.
- To prevent scratching and over-drilling, always wrap the drill bit with duct tape.

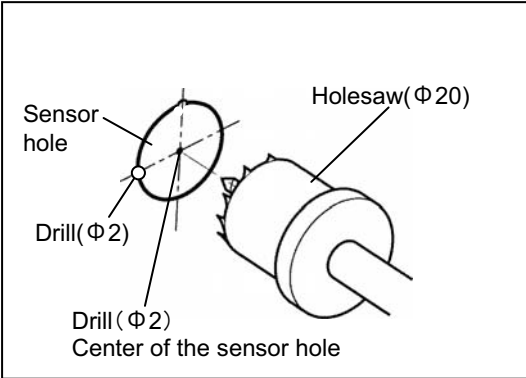

3. With the drill bit pointed perpendicular to the bumper, drill a 2 mm diam. hole in the marked position using a drill. (2 locations)
4. Drill a 20 mm diam. hole from the center of the sensor hole using a holesaw.

⚠ WARNING

- Be careful when handling drills and other sharp objects. If not handled properly, it could result in serious injury.

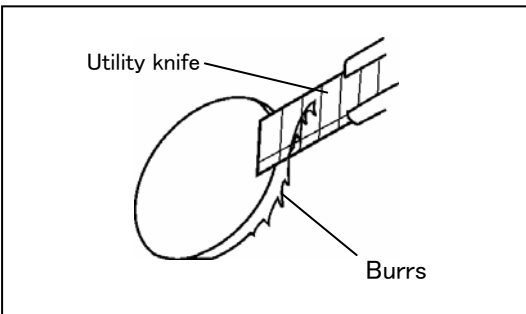

5. Remove burrs from the drilled holes using a round file.

⚠ CAUTION

- If the sensor is installed forcibly while the hole is small, it could deform the bumper.
- Make sure to remove burrs from the surface so that the bumper surface is smooth.

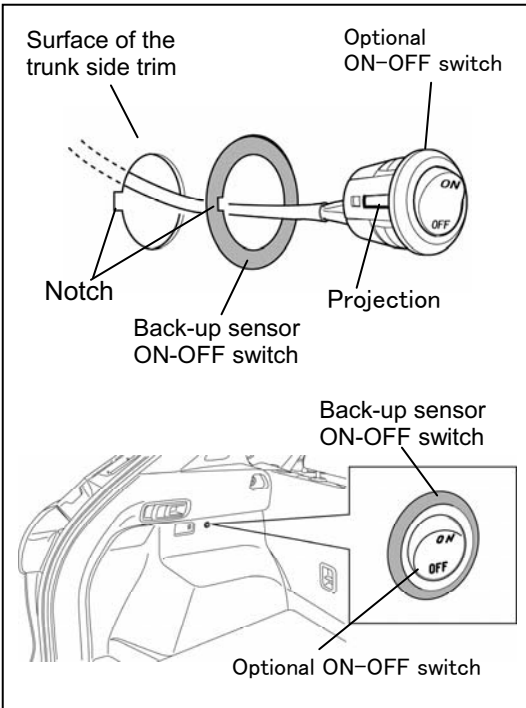

6. Remove the paper backing from the back-up sensor ON-OFF switch (label) and adhere the back-up sensor ON-OFF switch to the front side of the trunk side trim.
7. Route the system switch connector through the hole which was drilled from the surface of the trunk side trim using the hole saw, align the system switch projection to the lower panel notch, press it in the hole slowly, and secure it.

⚠ CAUTION

- After installation, verify that the system switch is securely pressed into the trunk side trim.
- Align the rib side of the trunk side trim and the notch to set it.

■ Control unit installation

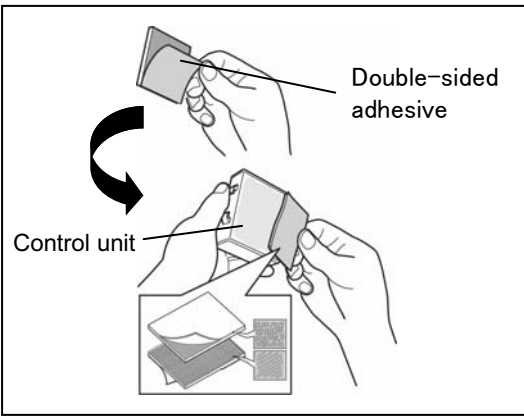

1. Affix double-sided adhesive tape to the control unit.

⚠ CAUTION

- Always remove dirt or oil because the adhesive strength of the double-sided adhesive tape weakens.

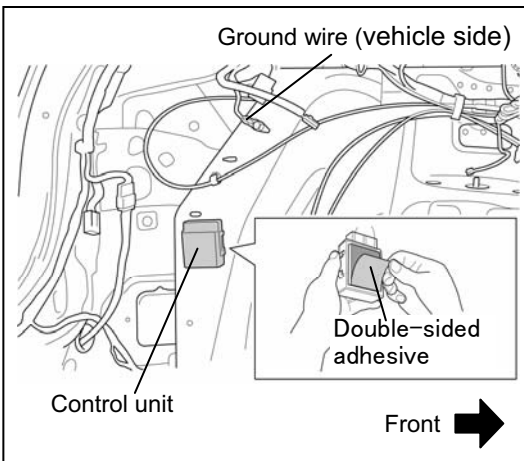

2. Peel off the double-sided adhesive tape backing and adhere the control unit to the body panel of the lower part inside of the trunk side trim (driver's side).

⚠ CAUTION

- Always remove dirt or oil because the adhesive strength of the double-sided adhesive tape weakens.

■ Buzzer installation

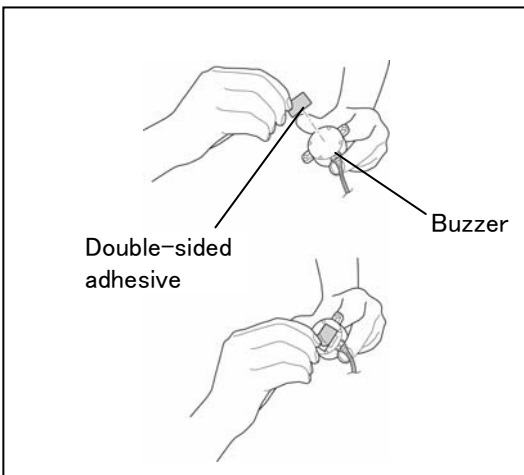

1. Affix double-sided adhesive tape to the buzzer.

⚠ CAUTION

- Always remove dirt or oil because the adhesive strength of the double-sided adhesive tape weakens.

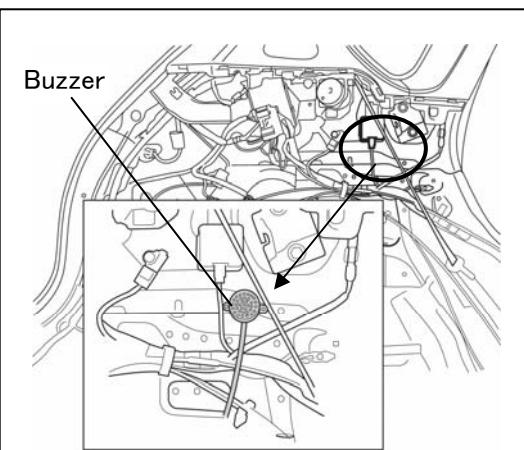

2. Peel off the double-sided adhesive tape backing and secure the rear buzzer to the body panel of the upper inside part of the trunk side trim (driver's side).

⚠ CAUTION

- Always remove dirt or oil because the adhesive strength of the double-sided adhesive tape weakens.

7. WIRING HARNESS

■ Sensor wiring harness

1. Connect the sensor wiring harness connector to the No.1, No.2, No.3, No.4 sensor and install the rear bumper.

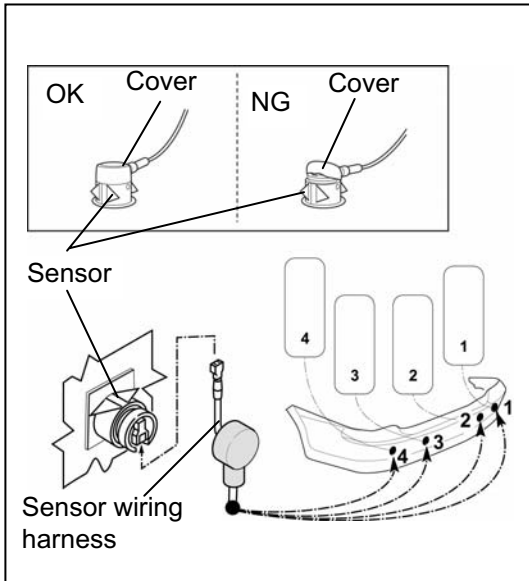

2. Affix the mount bases to the rear bumper. (4 locations)

⚠ CAUTION

- Clean the adhesion area with ISP alcohol.

3. Secure the sensor wiring harness using tie wraps. (4 locations)

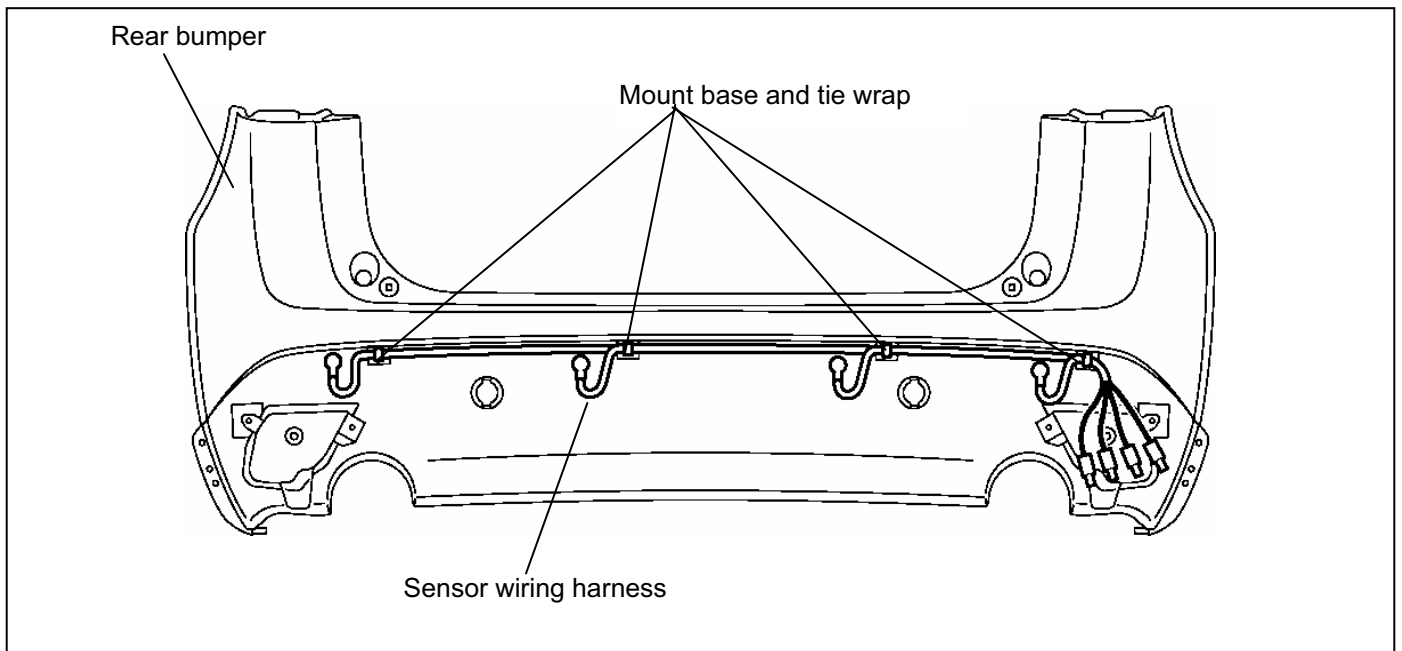

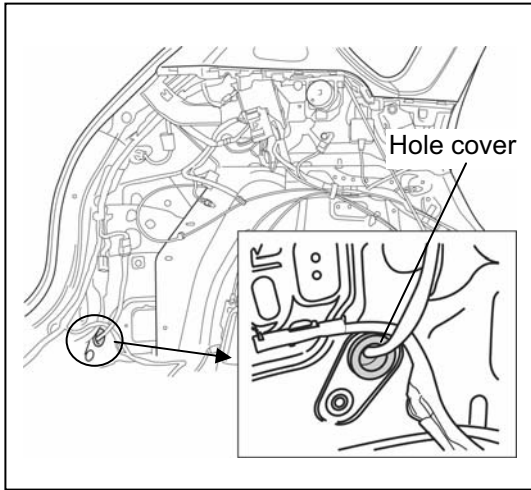

4. Remove the hole cover from the vehicle interior using needle-nose pliers.

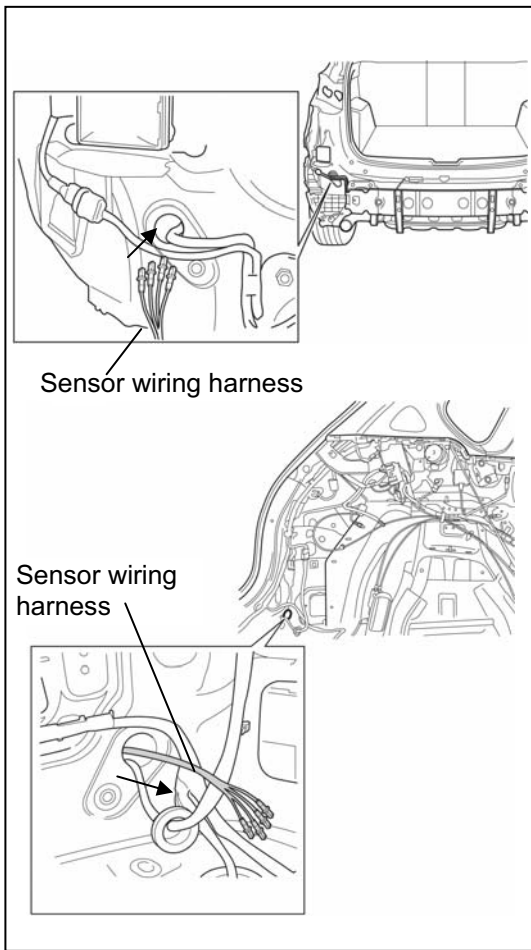

5. Pull the sensor wiring harness into the vehicle cabin.

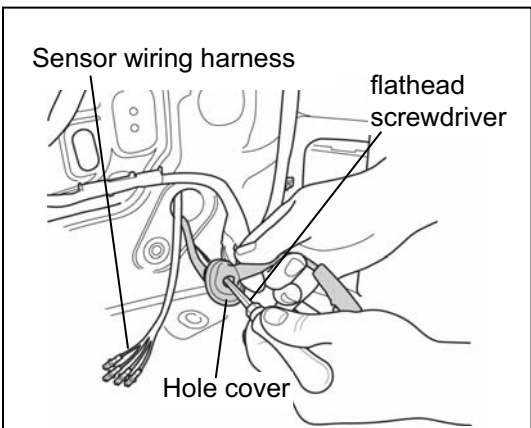

6. Enlarge the hole cover hole using a flathead screwdriver.

⚠ CAUTION

- Enlarge the hole cover hole to route the sensor wiring harness.

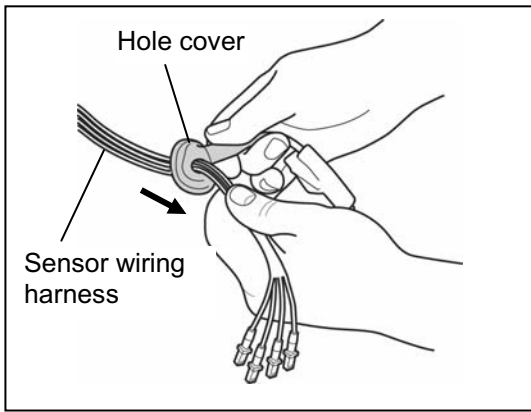

7. Route the sensor wiring harness through the hole cover.

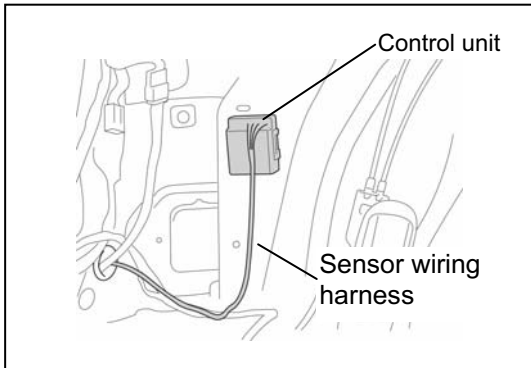

8. Connect the sensor wiring harness connector to the control unit.

⚠ CAUTION

- Make sure the connector is securely pressed in until a click sound is heard.

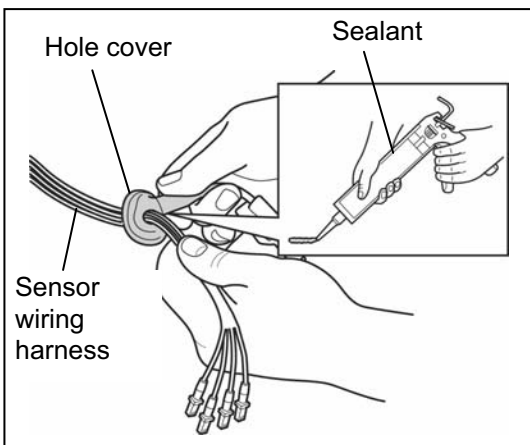

9. Apply sealant around the through-hole of the hole cover.

10. Install the hole cover to the vehicle.

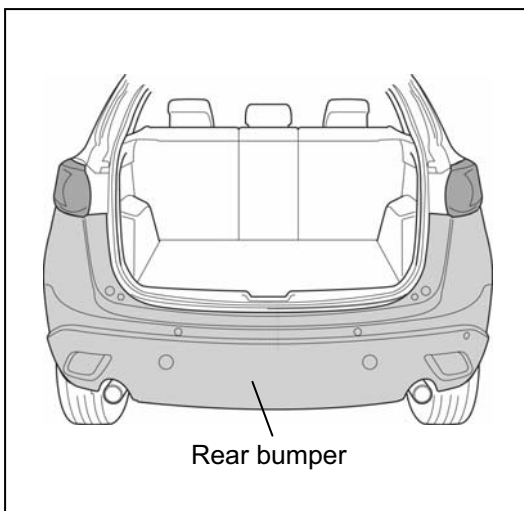

11. Install the rear bumper.

■ Main harness, Buzzer and ON-OFF switch wiring harness

1. Branch connect the wiring harness (R) for the BACK signal line branch of the main wiring harness to the RBCM (W/B) using an electro-tap.

⚠ **CAUTION**

- Connect an electro-tap to the indicated signal line securely. Misconnection may cause a system or vehicle malfunction.
- Wrap the electro-tap area using urethane tape to prevent the occurrence of abnormal noise.

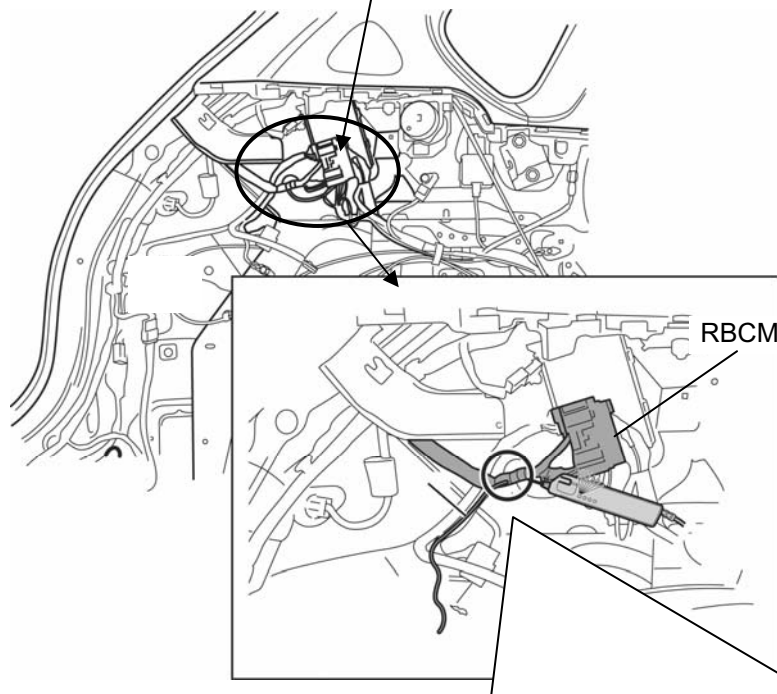
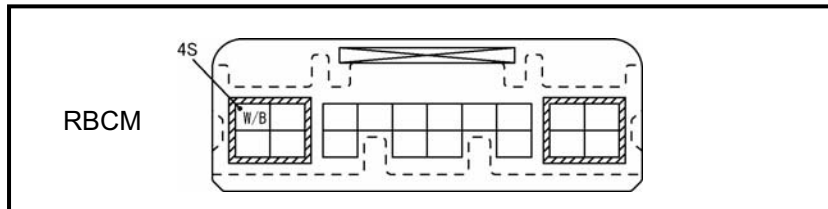

◆ Branch connection procedure using electro tap

Vehicle wiring
Harness(W/B)

Wiring harness (R)

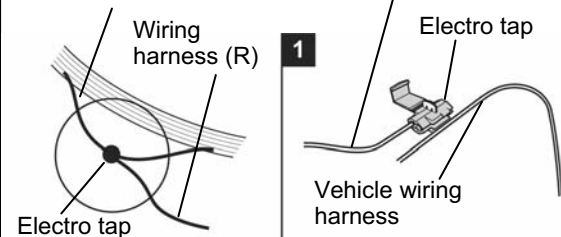

1. Insert the wiring harness (R) and vehicle wiring harness into the electro tap.
2. Firmly press the electro tap terminal using pliers.
3. Fold the electro tap in the direction of the arrow shown in the figure and lock it.

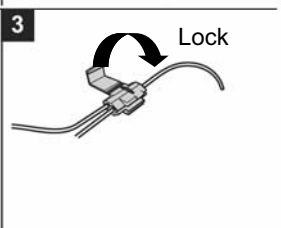
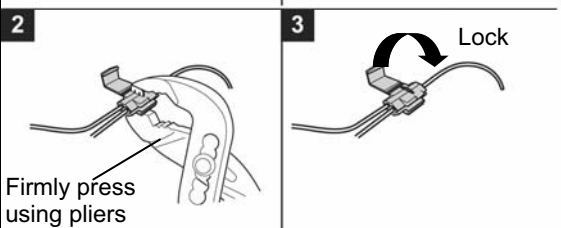

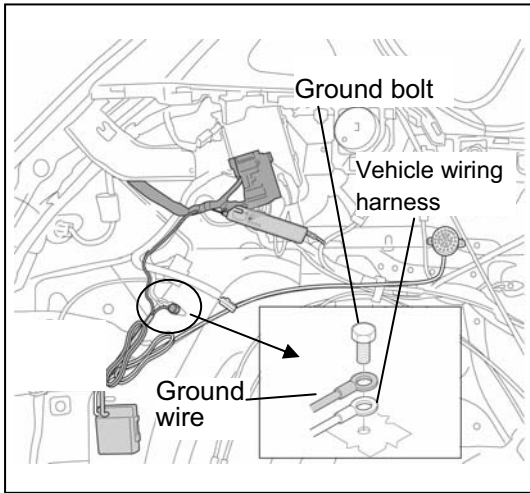

2. Tighten the ground wire together with the ground bolt on the vehicle side.

3. Cut the ground wire at the position approx. 120mm (0.39ft, 4.7 in) from the ground lug.

4. Electro-tap connect the cut ground wire with the ON-OFF switch wiring harness.

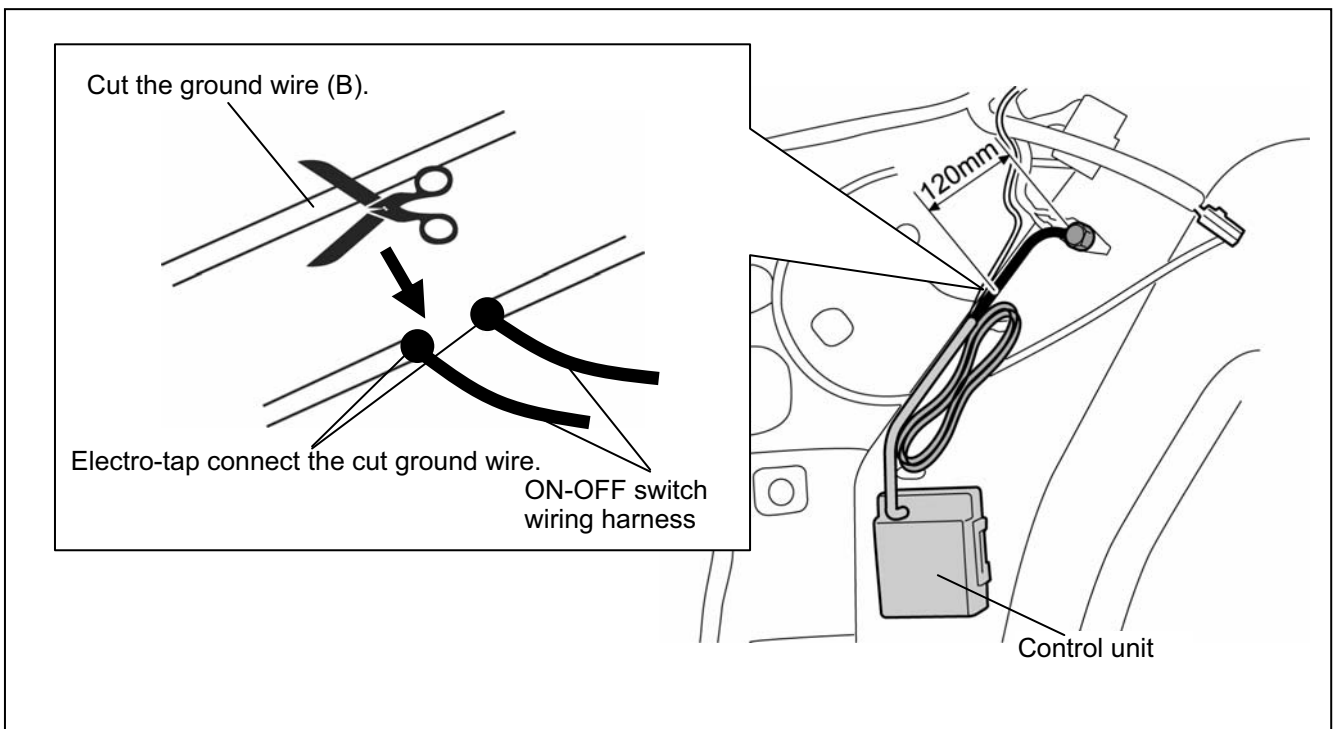

◆ Branching connection using electro-tap (ON-OFF switch harness)

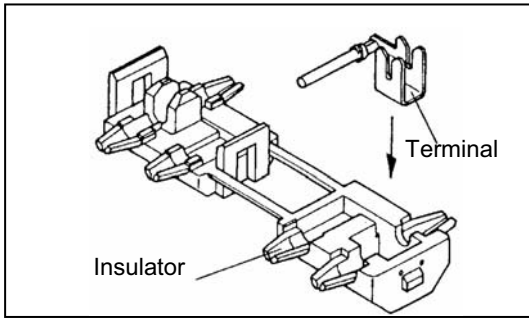

⚠ CAUTION

- The terminal is embedded in the insulator. If it is not, insert the terminal as shown in the figure and press it in until it is securely fixed.

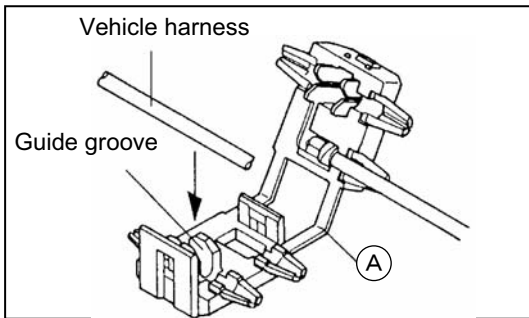

- Put the vehicle harness to be branch-connected into the guide groove.
- Fold back the electro-tap from the A part as shown in the figure.

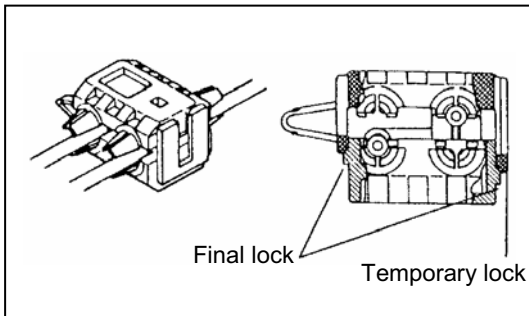

- Lock the electro-tap temporarily.

⚠ CAUTION

- The temporary lock is provided on only one side. Stop short of locking the final locks.

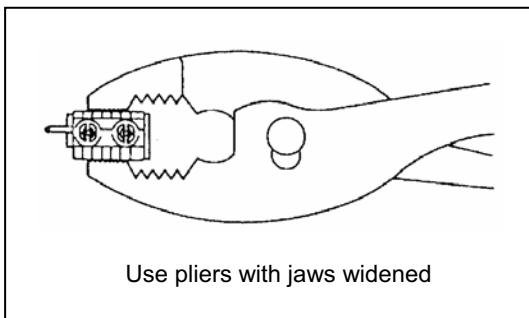

- With the nose surfaces of a pair of pliers, pinch the center of the electro-tap so that the force is applied evenly across the electro-tap, and engage the final locks on the both sides.

⚠ CAUTION

- Pinch the electro-tap until a clicking sound is heard from the final locks on the both sides.

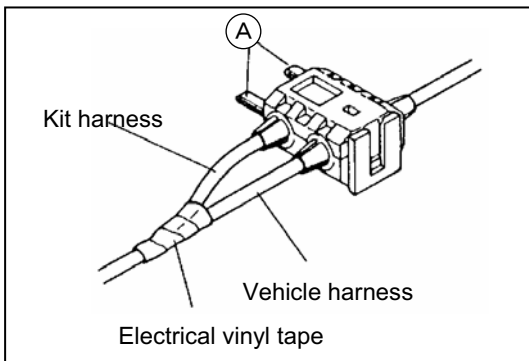

Cautions on use of electro-tap

- The electro-tap can be used without problem even if the A part is broken. You can use it as it is.
- When removing this accessory, do not disassemble the electro-tap, but cut the wire for the accessory leaving about 30 mm of it, and wrap it together with the vehicle harness with electrical tape for insulation.

⚠ CAUTION

- Do not reuse a used electro-tap.

5. Connect the buzzer wiring and main harness connectors to the control unit.

CAUTION

- Make sure the connector is securely pressed in until a click sound is heard.

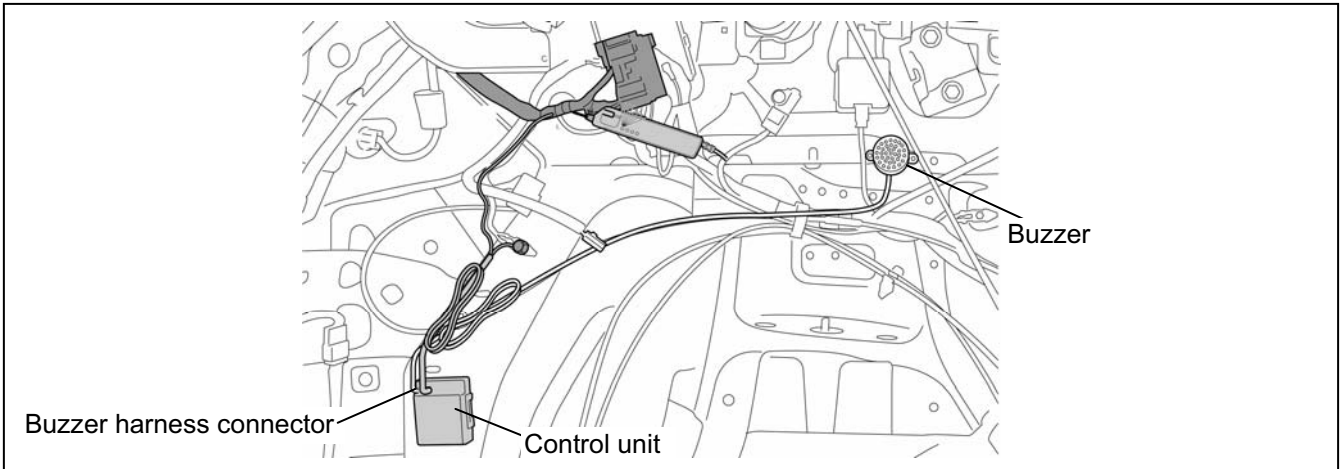

6. Secure the main sensor wiring harness to the vehicle wiring harness at 2 locations using tie wraps.
7. Secure the buzzer wiring harness to the vehicle wiring harness at 3 locations using tie wraps.
8. Wrap the electro-tap using cushioning tape.
9. Affix the ON-OFF switch wiring harness to the backside of the body panel with cushioning tapes.
10. Bundle the extra part of the main sensor and buzzer wiring harness at the position shown in the figure and secure it to the vehicle wiring harness at one point with tie wrap. (2 locations)
11. Secure the main wiring harness and buzzer wiring harness using a tie wrap.

CAUTION

- Cut off the remaining part using nippers or a similar tool when securing using tie wraps.

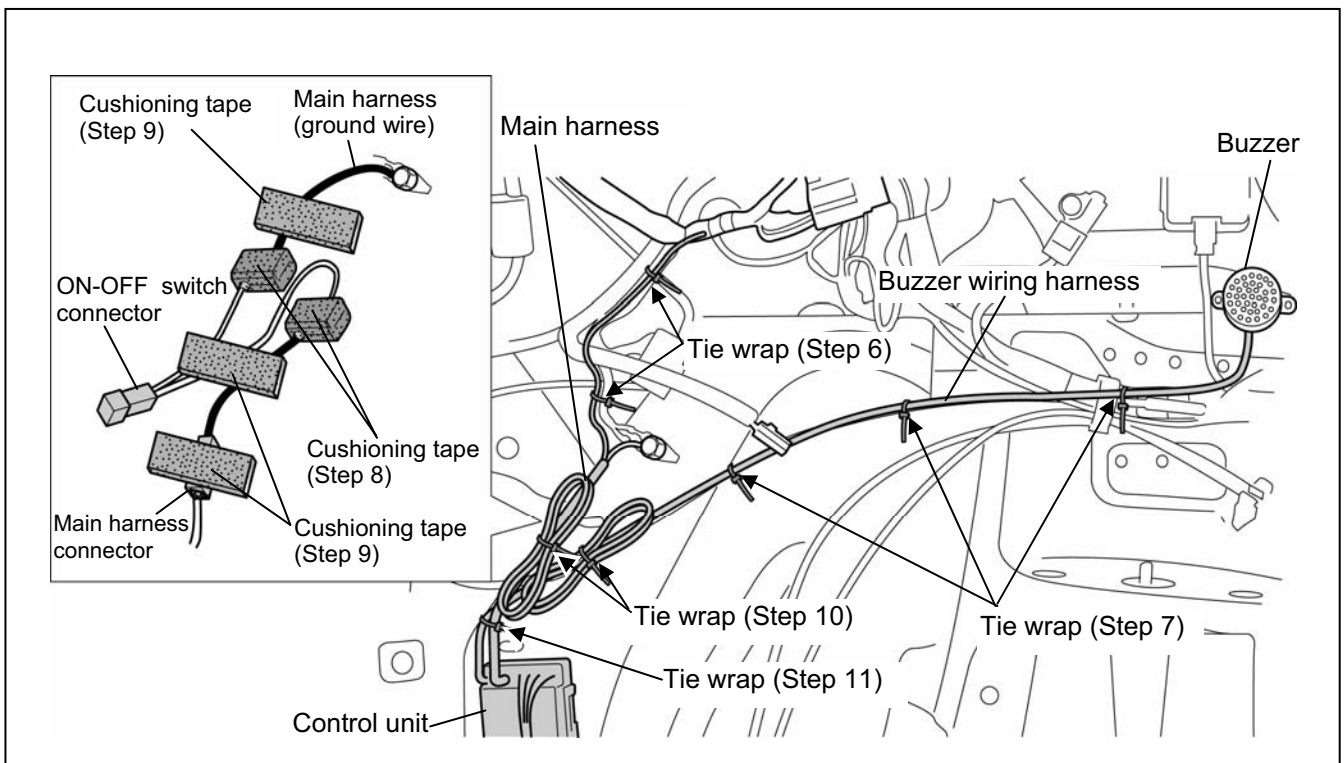

12. Connect the ON-OFF switch connector, then Install in the reverse order of removal trunk side trim.

CAUTION

- Make sure the connector is securely pressed in until a click sound is heard.

8. OPERATION CHECK

1. Install in the reverse order of removal.
2. After verifying the harness routing, connect the negative battery cable.

CAUTION

【Power window auto function】

- If the battery is disconnected, the automatic full open/close feature of the power window is disabled.
This feature can be recovered by the following procedure.
* For the power window with the automatic function, perform the all the initial settings.
 1. Turn the ignition switch to the ON position.
 2. Hold down the power window switch until the window is fully open.
 3. Pull up the power window switch to close the window and continue to pull it up for about two seconds after it is fully closed.
 4. If the feature does not function even after the ignition switch is turned off, contact an Authorized Mazda Dealer.

【TPMS system】

- If the battery is disconnected, the TPMS (Tire Pressure Monitoring System) initial setting is reset and the system may not operate normally.
This feature can be recovered by the following procedure.
 1. Adjust the tire pressure (verify tire pressure using label on body side with driver's door open).
 2. Turn the ignition switch to the ON position.
 3. Press the TPMS (SET) switch (long-press it until TPMS warning light in meter flashes two times and a beep sounds one time).
 4. Switch the ignition off.
 5. If the TPMS warning light illuminates or flashes even though the above procedure has been performed, contact an Authorized Mazda Dealer.

■ Operation check for parking sensor

⚠ CAUTION

- While performing the inspection, always switch the ignition on (engine off)
- Always set the wheel blocks on level ground before performing the verification alone.
- Operate the shift lever while fully depressing the clutch pedal (MT vehicles only) or the brake pedal so that the vehicle does not move accidentally.

Procedure	Operation	Inspection item(s)
1	<ul style="list-style-type: none"> • Switch the ignition ON (engine off) • Turn system switch on 	—
2	Bring a piece of cardboard close to each sensor to verify that the intermittent beeper sound changes depending on the distance. * When verifying, shift the shift lever to the reverse position.	<ul style="list-style-type: none"> • Connection between sensor wiring harness and control unit • Connection between each sensor and sensor wiring harness • Connection between control unit and buzzer
3	Verify that a beep sound is not heard even though cardboard comes close to each sensor when the system switch is turned off.	<ul style="list-style-type: none"> • Connection between switch and wiring harness

If a beeper sound is not heard or is heard continuously, verify the following troubleshooting:

Procedure	Operation	Inspection item(s)
1	Beep sound is not heard even if each sensor operates	<ul style="list-style-type: none"> • Is there a device generating ultrasonic waves near the vehicle? (Air compressor, high-pressure car washer, impact wrench, or electric drill)
2	While the system switch is turned on, the malfunction alarm sound (continuous or inconsistent sound for 1 s or more) is heard even though obstructions are not detected.	<ul style="list-style-type: none"> • Connection between sensor wiring harness and main wiring harness • Connection between sensor and sensor wiring harness
3	When the sensor is operated, a beep sound is heard continuously	<ul style="list-style-type: none"> • Are there obstructions around the vehicle? • Is the ground detected? <p>* If beep sound stops after placing cardboard on the ground, the ground may be detected. Is the sensor installed in the direction indicated in the instructions?</p> <div data-bbox="948 1375 1469 1697" data-label="Image"> </div>

- Operation condition
 - Is available when the ignition is switched ON.
 - The sensor detects obstructions when the shift lever is in the R position.

- Alarm (beeper) sound
 - The beeper operates (sounds) as follows while the system is operating.

◇Rear sensor

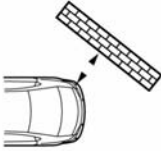
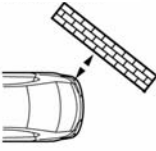
Distance between the vehicle and the obstruction	Buzzer sound
Approx. 2-1.5 ft (23.62-17.71 in) 	Intermittent sound
Approx. 1.5-1 ft (17.71-11.81 in) 	Fast intermittent sound
Within approx.1 ft (11.81 in) 	Continuous sound

INSTALLATION INSPECTION SHEET

**MAZDA
CX-5**

Parking distance sensor

**C851 V7 290 (Parking sensor kit)
KD33 V7 282 (Optional ON-OFF switch)**

A. Vehicle parts reinstallation

- Install removed vehicle parts in the reverse order of "VEHICLE PARTS REMOVAL".

⚠ CAUTION

- Make sure that the vehicle parts are clean before reinstalling. Clean any dirty parts.
- Verify that the connectors are securely connected.

Check

--

B. Inspection after installation

- Inspect the installed / reinstalled parts for the following items.

Inspection Parts	Inspection Items (○)			
	Clearance/Fit	Scratches/ Dirt/ Harness interference	Installation/ Tightening/ Engagement	Operation check
Rear sensor	○	○	○	○
Optional ON-OFF switch	○	○	○	○
Rear bumper	○	○	○	
Rear splash shield	○	○	○	
Rear over fender	○	○	○	
Rear combination light	○	○	○	○
Trunk side trim (LH)	○	○	○	○
Trunk end trim	○	○	○	
Trunk board	○	○	○	
Trunk covering	○	○	○	
Cover assy-tonneau	○	○	○	○
Negative battery cable	○	○	○	
Windows fully open and close automatically				○
TPMS				○

C. Important check items

- Inspect the installed / reinstalled parts for the following items.

No.	Item	Check
1	Are the battery cables securely tightened to the terminals? Tightening torque: 4.0-6.0 N·m {40.7—61.1 kgf·cm, 35.4 – 53.1 in·lbf }	

Installation inspection sheet

Date				
, ,				
VIN.				
Approved		Checked		Person in charge