

Heavy Duty Rural Mailboxes – 4850

Installation Instructions

U.S.P.S. APPROVED

Installing Mailbox on a Standard Mailbox Post

Thank you for selecting Salsbury's 4850 heavy duty rural mailbox. We are confident that the quality and construction of the mailbox will prove to be a good investment.

This instruction sheet is for installing the 4850 mailbox on a Salsbury standard mailbox post. Other installation instructions are available for installing the mailbox on a decorative post or on spreaders, mounting the post in a concrete footing, or mounting the 4815 newspaper holder.

When you install a curbside or roadside mailbox, make sure that it is easily accessible to the mail carrier. By regulation it should be 41" to 45" from the ground or street surface up to the inside floor of the mailbox. The door should be set back 6" to 8" back from the front face of the curb or the road edge. However, you should check with your local postmaster to ensure that the mailbox is installed according to local regulations.

The top plate of the standard rural mailbox post has four tapped holes. There are four 5/16" hex washer head bolts provided with the post to attach the mailbox to the post. Open the front door of the mailbox and install the four hex washer head bolts through the four holes in the inside floor of the mailbox and through the four tapped holes on the top plate of the standard rural mailbox post.

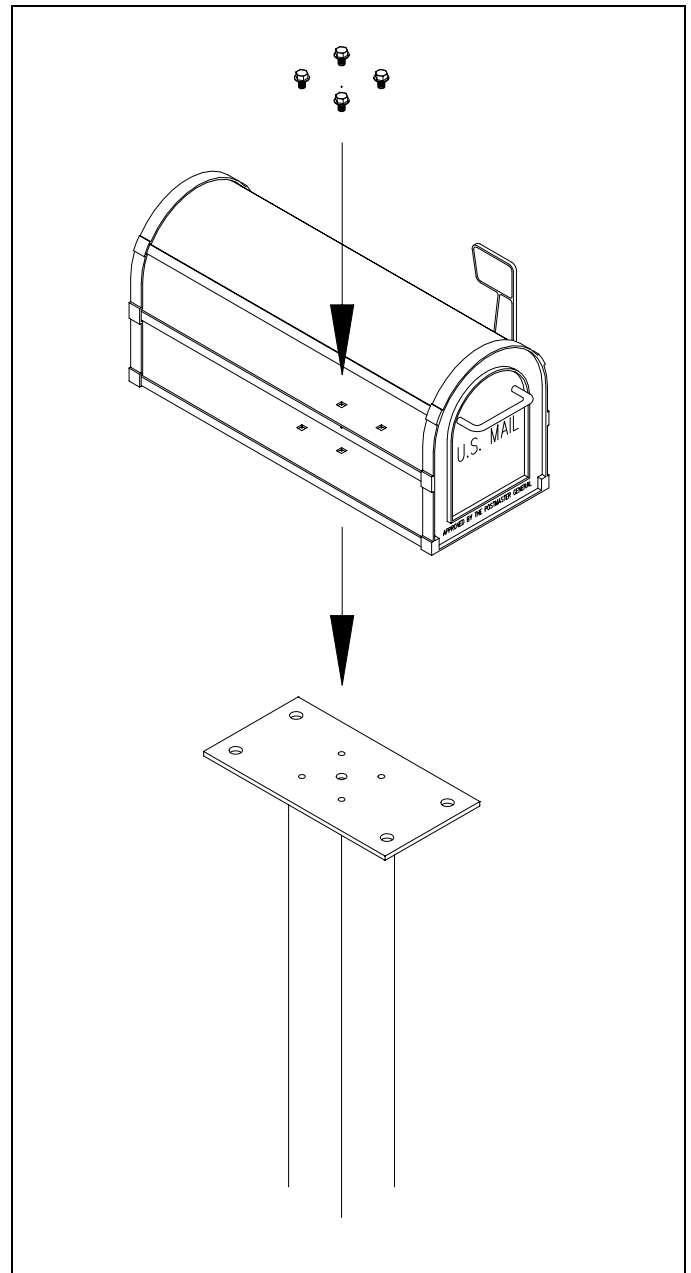

SALSBURY INDUSTRIES

1010 East 62nd Street, Los Angeles, CA 90001-1598
Phone: 1-800-624-5269 Int'l Phone: 323-846-6700
Fax: 1-800-624-5299 Int'l Fax: 323-846-6800
www.mailboxes.com engineering@mailboxes.com

Installation instructions are provided as general guidelines. It is advised that a professional installer be consulted. Salsbury Industries assumes no product assembly or installation liability.
Copyright © 2006 Salsbury Industries. All rights reserved.

Heavy Duty Rural Mailboxes – 4850

Newspaper Holder Installation Instructions

U.S.P.S. APPROVED

Installing Newspaper Holder under Mailbox

Thank you for selecting Salsbury's 4850 heavy duty rural mailbox. We are confident that the quality and construction of the mailbox will prove to be a good investment.

This instruction sheet is for installing the 4850 mailbox along with a 4815 newspaper holder. Other installation instructions are available for installing the mailbox on a standard post, installing the mailbox on a decorative post, installing the mailbox on spreaders, or installing the post in a concrete footing.

When you install a curbside or roadside mailbox, make sure that it is easily accessible to the mail carrier. By regulation it should be 41" to 45" from the ground or street surface up to the inside floor of the mailbox. The door should be set back 6" to 8" back from the front face of the curb or the road edge. However, you should check with your local postmaster to ensure that the mailbox is installed according to local regulations.

The mailbox is fastened to the newspaper holder with six (6) 5/16" carriage bolts, washers, and acorn nuts. The mailbox should be attached to the upper "A" holes when attached to a decorative post or the "B" holes when attached to a standard post as shown in Illustration 1. The assembled mailbox and newspaper holder is then fastened to the standard or decorative post with the appropriate hardware in the lower "A" or "B" holes, as required. When attaching to a decorative post, use the six (6) 5/16" carriage bolts. When attaching to a standard post, use the four (4) 5/16" hex washer head bolts included with the standard post. The four 5/16" hex washer head bolts are used to attach to the standard post, and the six (6) 5/16" carriage bolts with washers and acorn nuts are used to attach to the decorative post. See Illustration 2.

Illustration 1

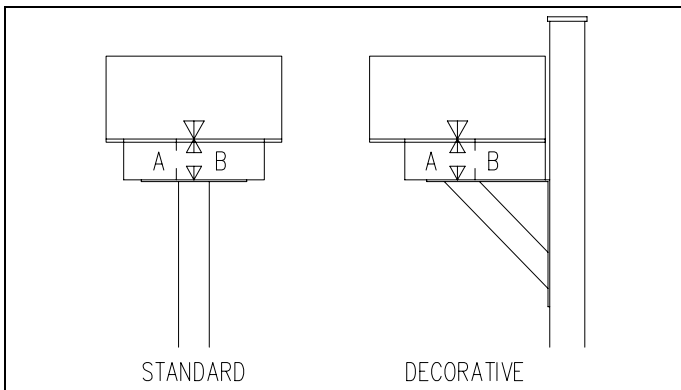
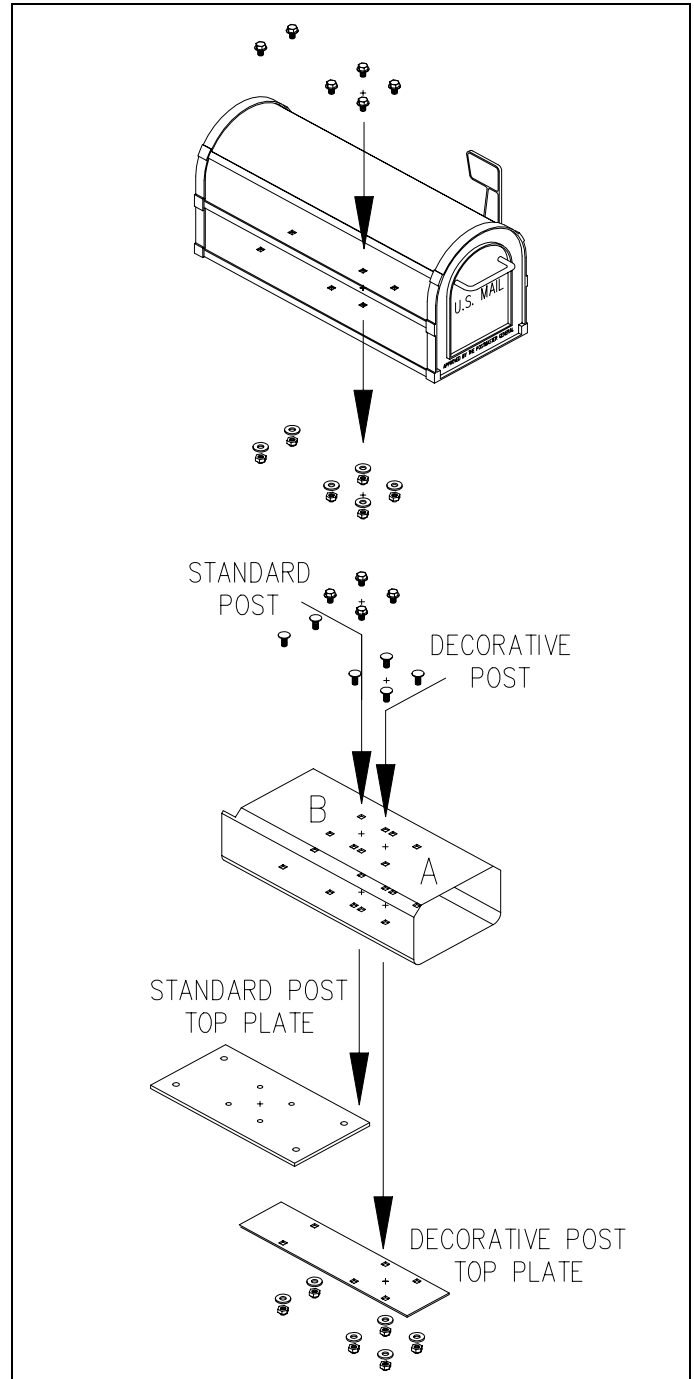

Illustration 2



SALSBUURY INDUSTRIES

1010 East 62nd Street, Los Angeles, CA 90001-1598
Phone: 1-800-624-5269 Int'l Phone: 323-846-6700
Fax: 1-800-624-5299 Int'l Fax: 323-846-6800
www.mailboxes.com engineering@mailboxes.com

Installation instructions are provided as general guidelines. It is advised that a professional installer be consulted. Salsbury Industries assumes no product assembly or installation liability.
Copyright © 2006 Salsbury Industries. All rights reserved.

Heavy Duty Rural Mailboxes – 4850

Decorative Post Installation Instructions

U.S.P.S. APPROVED

Installing Mailbox on a Decorative Post

Thank you for selecting Salsbury's 4850 heavy duty rural mailbox. We are confident that the quality and construction of the mailbox will prove to be a good investment.

This instruction sheet is for installing the 4850 mailbox on a Salsbury decorative mailbox post. Other installation instructions are available for installing the mailbox on a standard post or on spreaders, mounting the post in a concrete footing, or mounting the 4815 newspaper holder.

When you install a curbside or roadside mailbox, make sure that it is easily accessible to the mail carrier. By regulation it should be 41" to 45" from the ground or street surface up to the inside floor of the mailbox. The door should be set back 6" to 8" back from the front face of the curb or the road edge. However, you should check with your local postmaster to ensure that the mailbox is installed according to local regulations.

The mounting plate on the decorative post has six (6) plain holes. Set the mailbox on the mounting plate, open the door, and insert the six (6) 5/16" carriage bolts supplied with the mailbox into the six (6) holes in the floor of the mailbox. Install the 5/16" flat washers and 5/16" acorn nuts on the ends of the six (6) bolts protruding below the bottom of the post mounting plate.

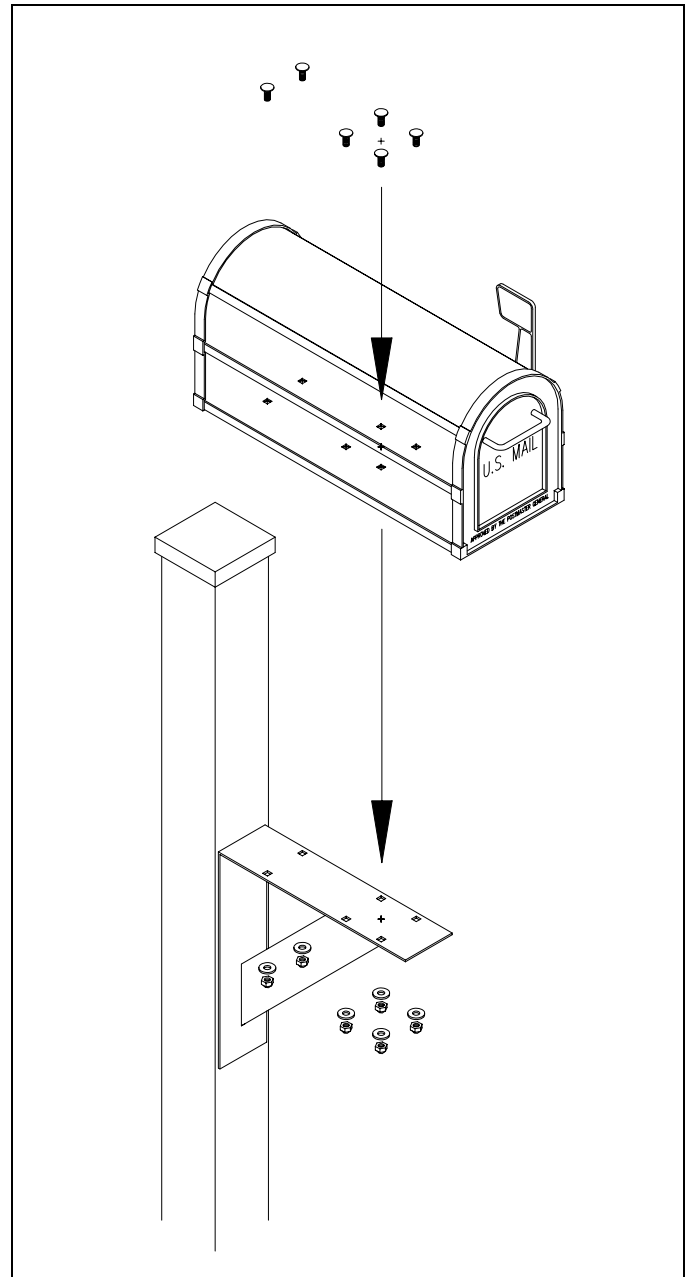

SALSBURY INDUSTRIES

1010 East 62nd Street, Los Angeles, CA 90001-1598
Phone: 1-800-624-5269 Int'l Phone: 323-846-6700
Fax: 1-800-624-5299 Int'l Fax: 323-846-6800
www.mailboxes.com engineering@mailboxes.com

Installation instructions are provided as general guidelines. It is advised that a professional installer be consulted. Salsbury Industries assumes no product assembly or installation liability.
Copyright © 2006 Salsbury Industries. All rights reserved.

Heavy Duty Rural Mailboxes – 4850

Spreader & Standard Post Installation Instructions

U.S.P.S. APPROVED

Installing Mailboxes on Spreader & Standard Post

Thank you for selecting Salisbury's 4850 heavy duty rural mailbox. We are confident that the quality and construction of the mailbox will prove to be a good investment.

This instruction sheet is for installing 4850 mailboxes on spreaders and Salisbury standard mailbox posts. Other installation instructions are available for installing the mailboxes and spreaders on a "modern" decorative post, mounting a single mailbox on a decorative or standard post, mounting the 4815 newspaper holder, and mounting the post in a concrete footing.

When you install a curbside or roadside mailbox, make sure that it is easily accessible to the mail carrier. By regulation it should be 41" to 45" from the ground or street surface up to the inside floor of the mailbox. The door should be set back 6" to 8" back from the front face of the curb or the road edge. However, you should check with your local postmaster to ensure that the mailbox is installed according to local regulations.

The spreaders are available in 3 widths, for mounting 2, 3, or 4 mailboxes. All 3 widths can be installed on the standard posts.

The mailboxes are mounted to the spreader using four 5/16" carriage bolts, 1/2" nylon spacers, washers, and acorn nuts. The carriage bolts are installed from the inside of the mailbox and the nylon spacers are placed between the mailboxes and the spreader. The washers and acorn nuts are installed under the spreader. The middle mailbox on the 3-wide spreader is jointly mounted to the spreader and the spreader to the post with the same set of long 5/16" hex washer bolts and nylon spacers.

The top plate of the standard post has 4 tapped holes. The spreader is mounted to the post using four 5/16" hex washer head bolts. The 2-wide and 4-wide spreaders are mounted directly to the post using the short 5/16" carriage bolts, while the 3-wide spreader is mounted to the post using the longer 5/16" carriage bolts and nylon spacers inside the middle mailbox, holding both the mailbox and the spreader to the post. Plastic caps are provided for the bolt heads to be used with the 2-wide and 4-wide spreaders. The plastic caps are not necessary for the 3-wide spreader, since the bolts are inside the middle mailbox.

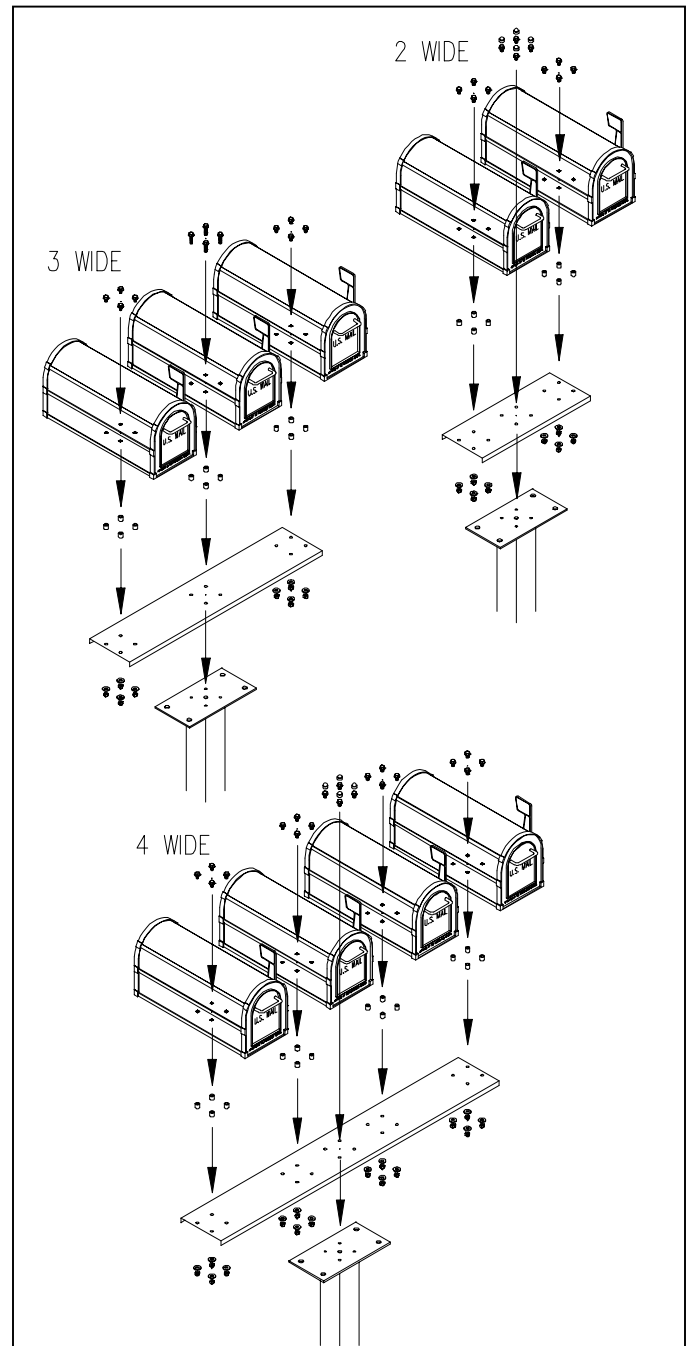

SALSBURY INDUSTRIES

1010 East 62nd Street, Los Angeles, CA 90001-1598
Phone: 1-800-624-5269 Int'l Phone: 323-846-6700
Fax: 1-800-624-5299 Int'l Fax: 323-846-6800
www.mailboxes.com engineering@mailboxes.com

Installation instructions are provided as general guidelines. It is advised that a professional installer be consulted. Salisbury Industries assumes no product assembly or installation liability.
Copyright © 2006 Salisbury Industries. All rights reserved.

Heavy Duty Rural Mailboxes – 4850

Spreader & Modern Post Installation Instructions

U.S.P.S. APPROVED

Installing Mailboxes on Spreader & Modern Decorative Post

Thank you for selecting Salsbury's 4850 heavy duty rural mailbox. We are confident that the quality and construction of the mailbox will prove to be a good investment.

This instruction sheet is for installing 4850 mailboxes on spreaders and Salsbury "modern" decorative mailbox posts. Other installation instructions are available for installing mailboxes on a spreader on a standard post, a single mailbox on a decorative or standard post, mounting the post in a concrete footing, or mounting the 4815 newspaper holder.

When you install a curbside or roadside mailbox, make sure that it is easily accessible to the mail carrier. By regulation it should be 41" to 45" from the ground or street surface up to the inside floor of the mailbox. The door should be set back 6" to 8" back from the front face of the curb or the road edge. However, you should check with your local postmaster to ensure that the mailbox is installed according to local regulations.

The spreaders are available in 3 widths, for mounting 2, 3, or 4 mailboxes. All 3 widths can be installed on the standard posts, while only the 2-wide or 3-wide spreader can be mounted on the "modern" decorative post (4825/4826).

The mailboxes are mounted to the 2-wide spreader using four 5/16" carriage bolts, 1/2" nylon spacers, washers, and acorn nuts. The carriage bolts are installed from the inside of the mailbox and the nylon spacers are placed between the mailboxes and the spreader. The washers and acorn nuts are installed under the spreader.

The 2-wide spreader is mounted to the post mounting plate using four 5/16" hex washer bolts, a 1-5/8" thick square aluminum spacer, washers, and acorn nuts. The aluminum spacer is inserted between the spreader and the post mounting plate.

The far left and far right mailboxes are mounted to the 3-wide spreader using four 5/16" carriage bolts, 1/2" nylon spacers, washers, and acorn nuts. The carriage bolts are installed from the inside of the mailbox and the nylon spacers are placed between the mailboxes and the spreader. The washers and acorn nuts are installed under the spreader.

The middle mailbox and the 3-wide spreader are jointly mounted to the post mounting plate with four longer 5/16" carriage bolts, 1/2" nylon spacers, a 1-5/8" thick square aluminum spacer, washers, and acorn nuts. The aluminum spacer is inserted between the spreader and the post mounting plate.

Plastic caps are provided for the bolt heads to be used with the 2-wide spreader. The plastic caps are not necessary for the 3-wide spreader, since the bolts are inside the middle mailbox.

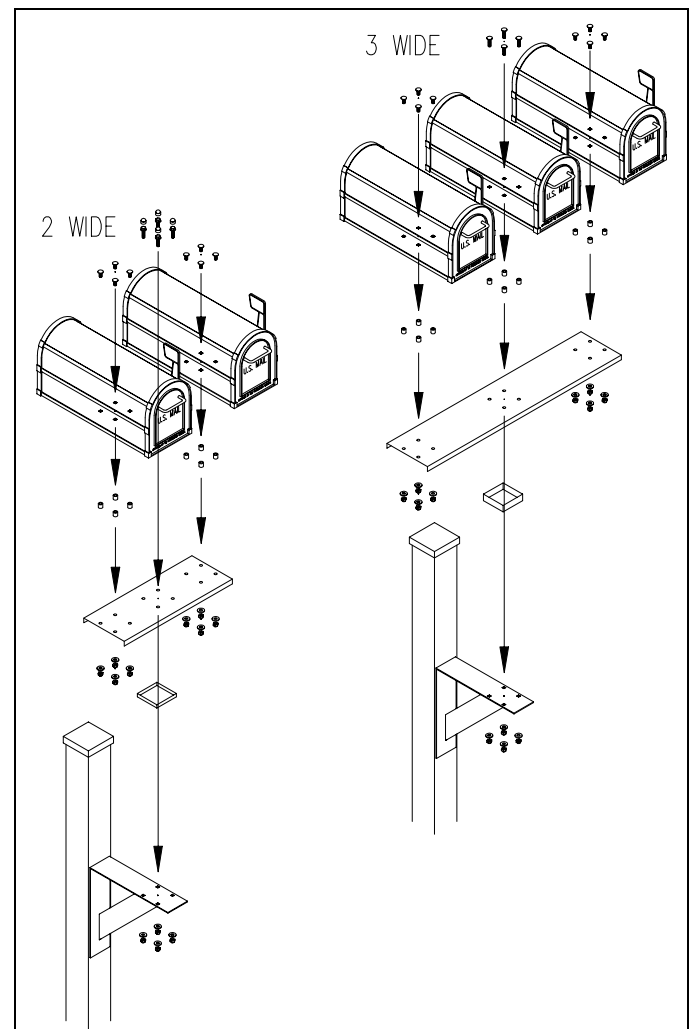

SALSBURY INDUSTRIES

1010 East 62nd Street, Los Angeles, CA 90001-1598
Phone: 1-800-624-5269 Int'l Phone: 323-846-6700
Fax: 1-800-624-5299 Int'l Fax: 323-846-6800
www.mailboxes.com engineering@mailboxes.com

Installation instructions are provided as general guidelines. It is advised that a professional installer be consulted. Salsbury Industries assumes no product assembly or installation liability. Copyright © 2006 Salsbury Industries. All rights reserved.

Heavy Duty Rural Mailboxes – 4850

In-Ground Mounted Post Installation Instructions

U.S.P.S. APPROVED

Installing the In-Ground Mounted Post for the Mailbox Into Concrete

When you install a curbside or rural mailbox, make sure that it is easily accessible to the mail carrier. By regulation it should be 41" to 45" from the ground or street surface up to the inside floor of the mailbox. The door should be set back 6" to 8" back from the front face of the curb or the road edge. However, you should check with your local postmaster to ensure that the mailbox is installed according to local regulations.

Dig the hole for the concrete footing, and prepare the concrete. You will need approximately 4-1/2 cubic feet. The top surface of the footing should be about 12" by 18" and extend 36" into the ground. See the illustration for the relative position of the rectangular footing to the post and mailbox. The bottom of the hole for the concrete footing should be filled with about 6" of gravel to promote drainage under the post. The top of the footing should be sloped for water runoff.

The concrete must be below the frost line. Otherwise the post will move when the ground freezes. Be careful not to puncture water, sewer, or gas lines when digging holes for footing.

Set the post in the hole and fill the hole with the prepared concrete mix. Prod the mix with a stick while filling to reduce any air pockets. If you want to conceal the concrete, pour it to within a few inches of the top of the hole and cover with soil after the concrete has set. Use a carpenter's level on the sides of the post to ensure that the post is aligned vertically. Periodically check the vertical alignment of the post as the concrete is curing.

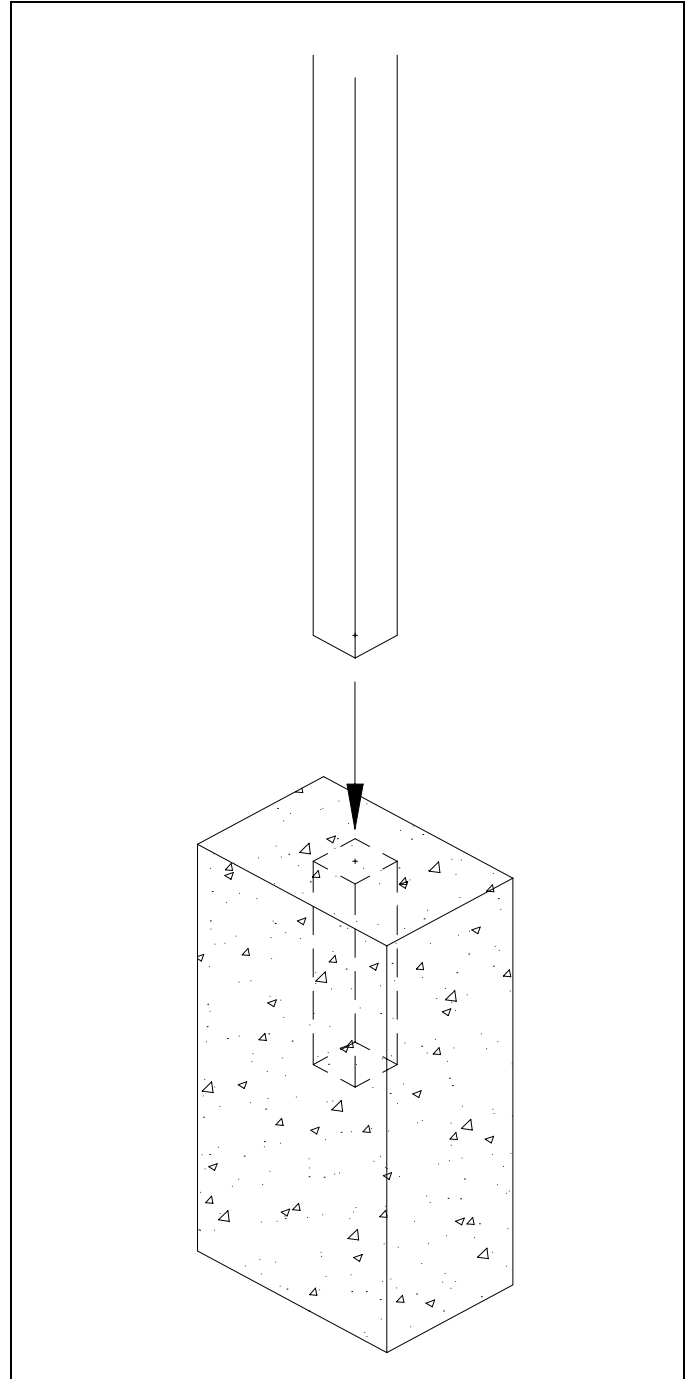

SALSBURY INDUSTRIES

1010 East 62nd Street, Los Angeles, CA 90001-1598
Phone: 1-800-624-5269 Int'l Phone: 323-846-6700
Fax: 1-800-624-5299 Int'l Fax: 323-846-6800
www.mailboxes.com engineering@mailboxes.com

Heavy Duty Rural Mailboxes – 4850

Bolt Mounted Post Installation Instructions

U.S.P.S. APPROVED

Installing the Bolt Mounted Post for the Mailbox onto Anchor Bolts

When you install a curbside or rural mailbox, make sure that it is easily accessible to the mail carrier. By regulation it should be 41" to 45" from the ground or street surface up to the inside floor of the mailbox. The door should be set back 6" to 8" back from the front face of the curb or the road edge. However, you should check with your local postmaster to ensure that the mailbox is installed according to local regulations.

Dig the hole for the concrete footing, and prepare the concrete. You will need approximately 4-1/2 cubic feet. The top surface of the footing should be about 12" by 18" and extend 36" into the ground. See the illustration for the relative position of the rectangular footing to the post and mailbox. The bottom of the hole for the concrete footing should be filled with about 6" of gravel to promote drainage under the post. The top of the footing should be sloped for water runoff.

The concrete must be below the frost line. Otherwise the post will move when the ground freezes. Be careful not to puncture water, sewer, or gas lines when digging holes for footing.

Four (4) 1/2"-13 by 8" long J-shaped anchor bolts and eight (8) 1/2"-13 nuts are provided. Attach the anchor bolts to the base of the post with four (4) nuts under and four (4) nuts over the bottom mounting plate. Pour the concrete into the hole, prodding the mix with a stick while filling to reduce any air pockets. Press the anchor bolts on the bottom of the post into the concrete until the bottom plate is resting on the top surface of the wet concrete. Use a carpenter's level on the sides of the post to ensure that the post is aligned vertically. Periodically check the vertical alignment of the post as the concrete is curing.

The concrete will shrink as it hardens, leaving a space between the anchor and the concrete when it is cured. To prevent this, loosen the top bolt one full turn prior to inserting into the wet concrete. After the anchor is inserted into the wet concrete, place your foot on the top of the threaded anchor and push down until the top nut is pressed against the anchor plate. After the concrete has hardened, re-tighten the top bolt.

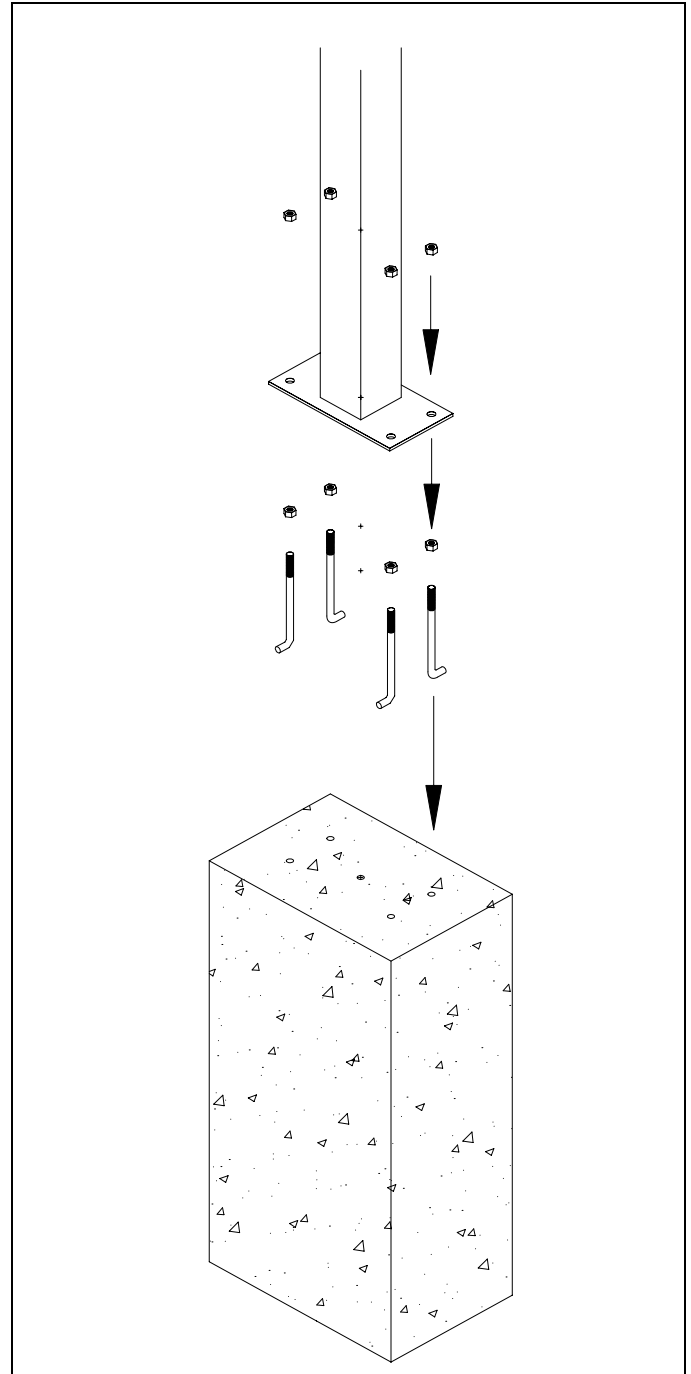

SALSBURY INDUSTRIES

1010 East 62nd Street, Los Angeles, CA 90001-1598
Phone: 1-800-624-5269 Int'l Phone: 323-846-6700
Fax: 1-800-624-5299 Int'l Fax: 323-846-6800
www.mailboxes.com engineering@mailboxes.com

Installation instructions are provided as general guidelines. It is advised that a professional installer be consulted. Salsbury Industries assumes no product assembly or installation liability. Copyright © 2008 Salsbury Industries. All rights reserved. (Rev. 02, 5/1/2008)