

LDS VACUUM PRODUCTS, INC.

SHORT TERM LEASING AGREEMENT

Alcatel ASM182TD+

Machine Model Number ASM182TD+
Company _____
Contact _____
Address _____
Address _____
Phone _____
Fax _____
Purchase Order Number _____
Serial Number TBD

Please read this agreement carefully. LDS leased equipment is subject to the following terms and conditions:

Fees

Lease payments:

- A. **Weekly Rate:** \$700.00 per week or \$2,500 per month, plus a one time \$125.00 clean-up and service fee applies to all leased equipment.
- B. **Late Charges** - Lease equipment must be received at the LDS plant within two (2) days after the lease termination. A \$125.00 per day late fee applies for each day beyond the two (2) day grace period until the equipment is received at the LDS plant. Please use LDS recommended carriers and special crate to avoid both late fees and damage charges.
- C. **Lost Crate Fee** - LDS provides a special shipping crate to minimize the possibility of shipping damage. The equipment must be returned in this special shipping crate or a lost crate fee of \$150.00 will apply.

General Lease Information

- A. All leased equipment returned to LDS must be in "original" condition (free from scratches and abuse). All equipment must be **protected from damage** and operated in a safe manner. Damages to equipment other than normal wear and tear will be billed at extra cost.
- B. The lessee must provide insurance to cover the full replacement cost of the equipment if damage or loss occurs while in the lessee's possession.
- C. This lease does not include installation, on site instruction or service. All required services on the above referenced equipment will be billed at the standard service rates in affect at the time the lease is executed.
- D. LDS provides our customers with a leak detector and sniffer probe only. It is the lessee's responsibility to provide all the connections from our equipment to your test piece. Please contact the LDS sales department to purchase the necessary fittings.

773 Big Tree Drive • Longwood FL 32750

Phone: (407) 862-4643 • Fax: (407) 862-8723 • E-mail: info@ldsvacuum.com

LDS VACUUM PRODUCTS, INC.

SHORT TERM LEASING AGREEMENT Alcatel ASM182TD+

- E. All leak detectors are set for general purpose parameters. If your application requires a special set up, please notify LDS prior to shipment.
- F. A hard copy of purchase order and a signed lease agreement must be faxed to LDS in order to reserve the next available rental.

Conditions Of Use

Applications involving corrosive materials, high concentrations of oxygen, hydrogen, nuclear materials are **prohibited**. The equipment is to be used for leak detection applications which do not adversely cause damage to the equipment. The customer is responsible for all damage resulting from exposing the equipment to potentially damaging conditions. The customer will be responsible for repair or replacement of the equipment under the above referenced conditions.

It shall be the customer's responsibility to contact LDS for **prior approval** if the application for use falls into the above category. If there is any question pertaining to the suitability of the equipment for a specific application, contact LDS.

Maintenance and Care

Oil changes and other minor maintenance items will be required if the lease extends beyond ninety (90) days. Contact LDS service department for recommendations. The cost this maintenance is not included in the lease price.

Lease Extension

The lease can be extended based on the original terms and conditions by contacting LDS and requesting a lease extension. A letter authorizing an extension of the lease will be issued by LDS.

Purchase Of Rental Equipment

Contact LDS to determine if the equipment is eligible for purchase. The purchase price will be the total replacement value as indicated on this lease **less a credit of 15%** of the total lease payments submitted to LDS for this lease agreement. Prior rentals fees are not eligible for credit.

Termination of rental period

The equipment must be returned to LDS upon termination of the lease. LDS allows two (2) shipping days from the termination date for the equipment to be received at the LDS plant.

Return Shipping

- A. The equipment shall be returned to LDS in the original shipping container designed to safely return this equipment to the LDS facility.
- B. The customer is responsible for all transportation charges. All equipment must be insured for the total replacement value of **\$30,000.00**.
- C. Because of **guaranteed damage** to mass spectrometer units, **this equipment CANNOT be shipped via Federal Express**. LDS recommends the use of Yellow Exact, Emery and Burlington (insured).

773 Big Tree Drive · Longwood FL 32750

Phone: (407) 862-4643 · Fax: (407) 862-8723 · E-mail: info@ldsvacuum.com

LDS VACUUM PRODUCTS, INC.

SHORT TERM LEASING AGREEMENT
Alcatel ASM182TD+

Note: Other Carriers: The customer has the option of using a carrier other than Yellow Exact. The customer will be responsible for any shipping damage not covered by insurance and subject to late fees as specified in this lease if the equipment does not arrive at LDS within two (2) days after then rental period has ended.

These warranties are expressly IN LIEU of any other express or implied warranty and of any other obligation on the part of LDS, LDS assumes no liability in any event, for consequential damages, for anticipated or lost profits, incidental damages or loss of time or other losses incurred by the Purchaser or any third party in connection with equipment covered by the warranty or otherwise. No representation is made as to application or conditions of the use unless expressly set forth in LDS' acceptance of Purchaser's Order.

As the customer, you are responsible for all rental payments and freight cost. If equipment is lost or damaged during the rental period, you will be responsible for all rental fees and replacement value.

This agreement shall supersede the terms and conditions of any purchase order issued to LDS. The terms of this agreement are **not negotiable**. **LDS will not send out any rental equipment without a signed customer agreement.**

Customer Representative

Date

***Attention:**

Canadian Customers Only: Credit card only payment terms is required

New Rental Customers: Please fax us your credit references for Net 30 terms. Credit checks will take one (1) business day to complete. However, **credit card hold is required (Visa, Mastercard or American Express) to rent this equipment. If payment is not made within sixty (60) days, your credit card will be charged. Please include this information here:**

Card Type	Card Number	Expires	Card Holder	3-Digit Code Visa/Master Only (Back Of Card)

SHORT TERM LEASING AGREEMENT
Alcatel ASM182TD+

Other Important Notes Regarding Rental Equipment

- a. Please fax us your signed lease agreement by 2:00pm EST to ship the same day.
- b. Your equipment is supplied with a sniffer probe and manual only. If additional parts are required, please contact LDS.
- c. Your rental begins when you RECEIVE the equipment and ends exactly one week after. In other words, weekly rentals are from Wednesday to Wednesday (example).
- d. Shipping to and from your facility is not included in the rental price.
- e. Unfortunately, LDS cannot rent to our out of country customers (except Canada). However, if you are part of a larger organization, LDS will be happy to ship the equipment to your US organization and they can forward the equipment.
- f. We are here to help you... If you need assistance after hours or plan on performing your test during a weekend, please ask LDS for an after hours telephone number.

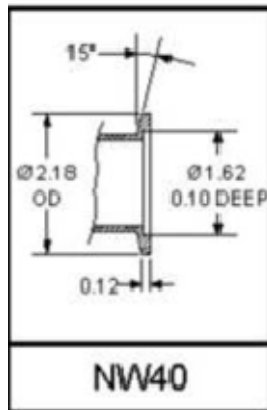

PORT SIZE FOR ASM182TD+