



Electronic Gas Dryer

PRODUCT MODEL NUMBERS

WGD8300S

Gas supply: Dryer is equipped for use with NATURAL gas. Dryer can be converted to L.P. gas. When rigid pipe is used it should be 1/2 inch IPS. When acceptable to the gas supplier and local codes, 3/8 inch approved tubing may be used for lengths under 20 feet. For lengths over 20 feet, larger tubing should be used. Pipe-joint compounds resistant to the action of L.P. gas must be used. If local codes permit, it is recommended that new flexible metal tubing, design-certified by AGA or CSA, be used for connecting the appliance to the rigid gas supply line. (The gas pipe which extends through the lower rear of the appliance has 3/8 inch male pipe thread.) An individual manual shutoff valve must be installed within 6 feet of the dryer in accordance with the National Fuel Gas Code ANSI Z223.1.

Electrical: A four-wire or three-wire, single phase, 120-volt, 60 Hz, AC-only, electrical supply is required on a separate 15 or 20 amp circuit, fused on both sides of the line. A time-delay fuse or circuit breaker is recommended.

Exhaust venting: Exhaust your dryer to the outside. Four inch diameter vent is required. Rigid or flexible metal exhaust vent must be used. Do Not use plastic or metal foil vent. Exhaust outlet hood must be at least 12 inches from the ground or any object that may be in the path of the exhaust.

EXHAUST VENTING

Recommended hood styles

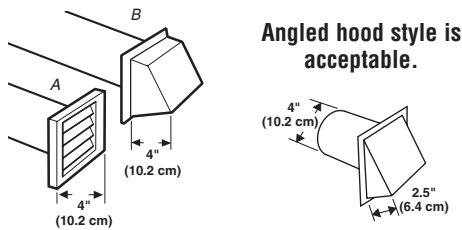

Angled hood style is acceptable.

A. Louvered hood style
B. Box hood style

Number of 90° turns or elbows	Type of vent	Box or Louvered hoods	Angled hoods
0	Rigid metal	64 ft (20 m)	58 ft (17.7 m)
	Flexible metal	36 ft (11 m)	28 ft (8.5 m)
1	Rigid metal	54 ft (16.5 m)	48 ft (14.6 m)
	Flexible metal	31 ft (9.4 m)	23 ft (7 m)
2	Rigid metal	44 ft (13.4 m)	38 ft (11.6 m)
	Flexible metal	27 ft (8.2 m)	19 ft (5.8 m)
3	Rigid metal	35 ft (10.7 m)	29 ft (8.8 m)
	Flexible metal	25 ft (7.6 m)	17 ft (5.2 m)
4	Rigid metal	27 ft (8.2 m)	21 ft (6.4 m)
	Flexible metal	23 ft (7 m)	15 ft (4.6 m)

NOTE: Side and bottom exhaust installations have a 90° turn inside the dryer. To determine maximum exhaust length, add one 90° turn to the chart.

OVERALL DIMENSIONS

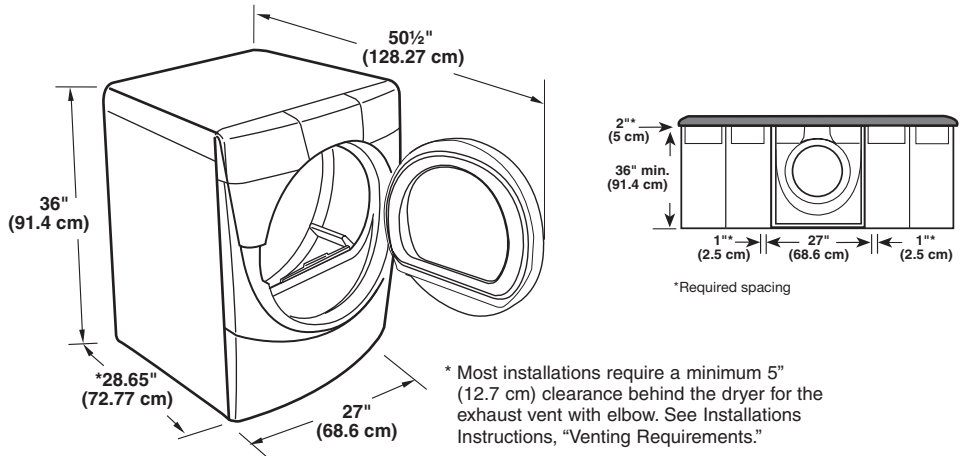

* Most installations require a minimum 5" (12.7 cm) clearance behind the dryer for the exhaust vent with elbow. See Installations Instructions, "Venting Requirements."

RECESSED AREA AND CLOSET INSTALLATION

For closet installation, with a door, the minimum ventilation openings in the top and bottom of the door are required. Louvered doors with equivalent air ventilation openings in the top and bottom are acceptable.

Dryer only

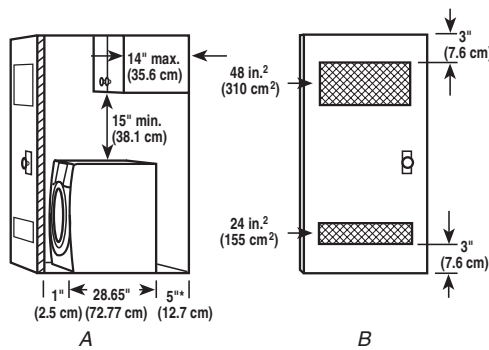

A. Side view - closet or confined area
B. Closet door with vents

*Side or bottom venting - 0" (0 cm) spacing is allowed

Dryer on pedestal

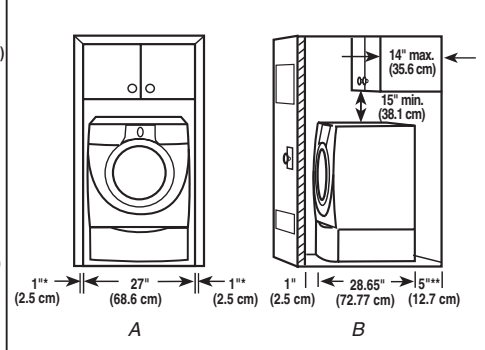

A. Recessed area
B. Side view - closet or confined area

*Required spacing

**Side or bottom venting - 0" (0 cm) spacing is allowed

Recommended installation spacing for cabinet installation

For cabinet installation, with a door, the minimum ventilation openings in the top are required.

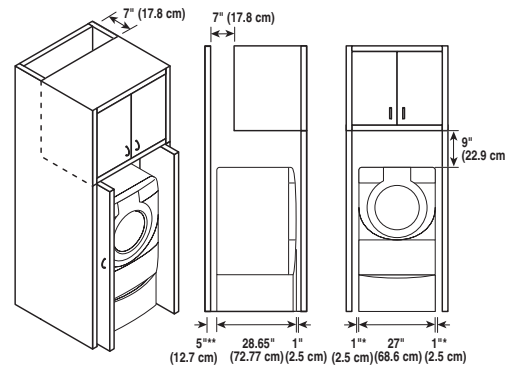

*Required spacing

**Side or bottom venting - 0" (0 cm) spacing is allowed

Select the route that will provide the straightest and most direct path outdoors. Plan the installation to use the fewest number of elbows and turns. Use the fewest 90° turns possible.

Do not use vent runs longer than specified in vent length chart.

Determine the number of elbows you will need.