

INSTALLATION INSTRUCTIONS

MICROWAVE BUILT-IN TRIM KIT

Retain for Future Reference

VIKING RANGE CORPORATION
111 Front Street
Greenwood, Mississippi 38930 USA
(662) 455-1200

IMPORTANT - PLEASE READ AND FOLLOW

- Before beginning, please read these instructions completely and carefully.
- Be sure to DISCONNECT THE PLUG of the microwave oven from the electrical outlet before installing the built-in trim kit. Remove the turntable from the oven cavity.
- Because the kit includes metal parts, caution should be used in handling and installation to avoid the possibility of injury.
- Do not remove permanently affixed labels, warnings, or plates from the product. This may void the warranty.
- Please observe all local and national codes and ordinances.
- **The installer should leave these instructions with the consumer who should retain for local inspector's use and for future reference.**

THIS BUILT-IN KIT IS DESIGNED FOR USE ONLY WITH VIKING MICROWAVE OVENS SPECIFYING BUILT-IN KIT VMTK270, VMTK300, OR VMTK360 FOR PROFESSIONAL UNITS AND DMTK270 OR DMTK300 FOR DESIGNER UNITS ON THE RATING LABEL ON THE LEFT SIDE WALL OF THE OVEN CAVITY.

IF YOUR LOWER CONVENTIONAL OVEN IS NOT LISTED IN THE USE AND CARE MANUAL OF THE MICROWAVE OVEN, THEN DO NOT INSTALL THE MICROWAVE OVEN ABOVE IT OR IN ANY AREA WHERE HEAT AND STEAM ARE GENERATED; FOR EXAMPLE, NEXT TO OR ABOVE A CONVENTIONAL RANGE.

PARTS INCLUDED IN THE VMTK KIT

- 1) Front Frame Assembly - QTY 1

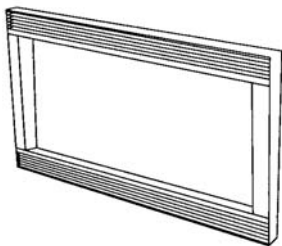

- 2) Exhaust Duct Assembly - QTY 1

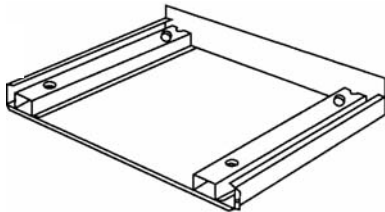

- 3) Screw A (1/2" length) - QTY 2



- 4) Screw B (1 3/4" length) - QTY 4



PARTS INCLUDED IN THE DMTK KIT

- 1) Frame Assembly - QTY 1
Front Frame Sub-Assembly;
Back Frame Sub-Assembly

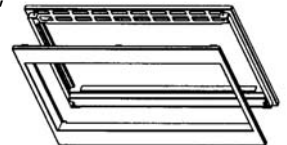

- 2) Exhaust Duct Assembly - QTY 1

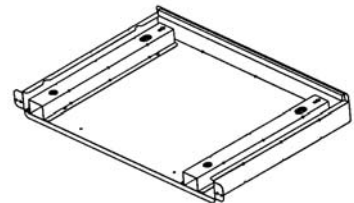

- 3) Screw A (1/2" length) - QTY 2



- 4) Screw B (1 1/2" length) - QTY 4



- 5) Screw C (3/8" length) - QTY 4



BASIC SPECIFICATIONS

	Microwave Oven VMOS200	Built-In Trim Kits		
		VMTK270	VMTK300	VMTK360
Overall Width	24" (60.9 cm)	26-1/2" (67.3 cm)	29-1/2" (74.9 cm)	35-1/4" (89.5 cm)
Overall Height from Bottom	13-3/8" (33.9 cm)	18-1/4" (46.3 cm)	18-1/4" (46.3 cm)	18-1/4" (46.3 cm)
Overall Depth from Rear	19-3/8" (49.2 cm)	N/A	N/A	N/A
Oven Interior	Width - 17-3/8" (44.1 cm) Height - 10-1/2" (26.6 cm) Depth - 18-5/8" (47.3 cm) Overall - 2.0 cu. ft.	N/A	N/A	N/A
Cutout Width	N/A	Min. - 24-3/8" (61.9 cm) Max. - 24-11/16" (62.7 cm)		
Cutout Height	N/A	Min. - 16-3/4" (42.5 cm) Max. - 17" (43.2 cm)		
Cutout Depth	N/A	Min. 20" (50.8 cm)		
Electrical Requirements	120VAC/60 Hz	N/A	N/A	N/A
Max. Amp Usage	1.65 KW; 13.5 amps	N/A	N/A	N/A
Approximate Shipping Wt.	55 lbs. (24.7 kg)	14 lbs. (6.5 kg)	15 lbs. (6.9 kg)	16 lbs. (6.9 kg)

	Microwave Oven DMOS200	Built-In Trim Kits	
		DMTK270	DMTK300
Overall Width	24" (60.9 cm)	26-1/2" (67.3 cm)	29-1/2" (74.9 cm)
Overall Height from Bottom	13-3/8" (33.9 cm)	18-1/4" (46.3 cm)	18-1/4" (46.3 cm)
Overall Depth from Rear	19-3/8" (49.2 cm)	N/A	N/A
Oven Interior	Width - 17-3/8" (44.1 cm) Height - 10-1/2" (26.6 cm) Depth - 18-5/8" (47.3 cm) Overall - 2.0 cu. ft.	N/A	N/A
Cutout Width	N/A	Min. - 24-3/8" (61.9 cm) Max. - 24-11/16" (62.7 cm)	
Cutout Height	N/A	Min. - 16-3/4" (42.5 cm) Max. - 17" (43.2 cm)	
Cutout Depth	N/A	Min. 20" (50.8 cm)	
Electrical Requirements	120VAC/60 Hz	N/A	N/A
Max. Amp Usage	1.65 KW; 13.5 amps	N/A	N/A
Approximate Shipping Wt.	55 lbs. (24.7 kg)	14 lbs. (6.5 kg)	15 lbs. (6.9 kg)

CABINET OR WALL CUTOUT

Cutout Dimensions

Height (A)		
Minimum	16 3/4"	(42.5 cm)
Maximum	17"	(43.2 cm)
Width (B)		
Minimum	24 3/8"	(61.9 cm)
Maximum	24 11/16"	(62.7 cm)
Depth (C)		
Minimum	20"	(50.8 cm)

ELECTRICAL OUTLET LOCATION

Outlet should NOT be in the shaded area as indicated on Illustration 1

NOTE 1: If the Depth (C) dimension is greater than 21" (53.3 cm), the outlet location may be in any area on the rear wall.

NOTE 2: The floor of the opening should be constructed of plywood strong enough to support the weight of the oven and floor load (approximately 100 pounds). The floor should be level for proper operation of the oven. Be sure to check the local building code as it may require that the opening be enclosed with side, ceiling and rear partition. The proper functioning of the oven does not require the enclosure.

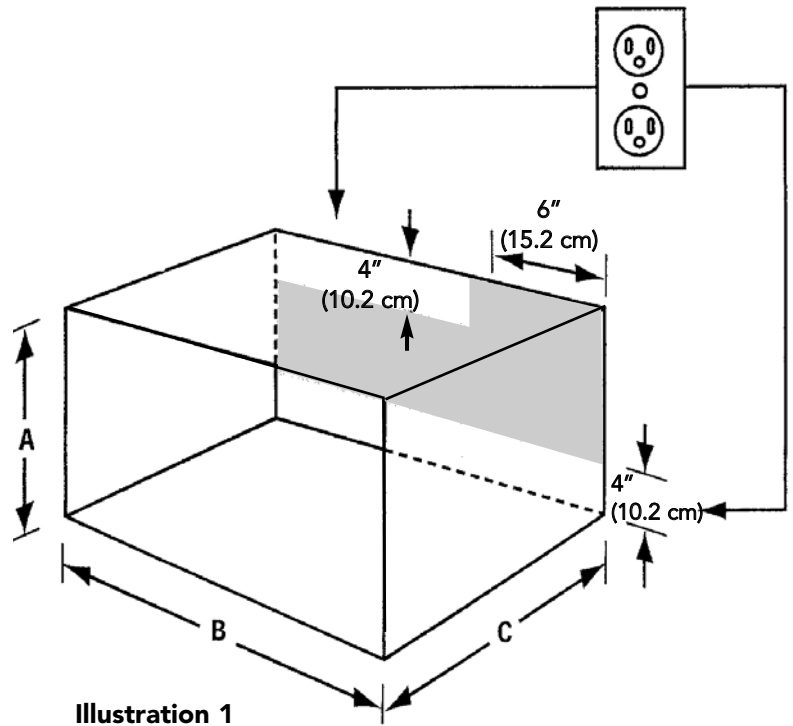
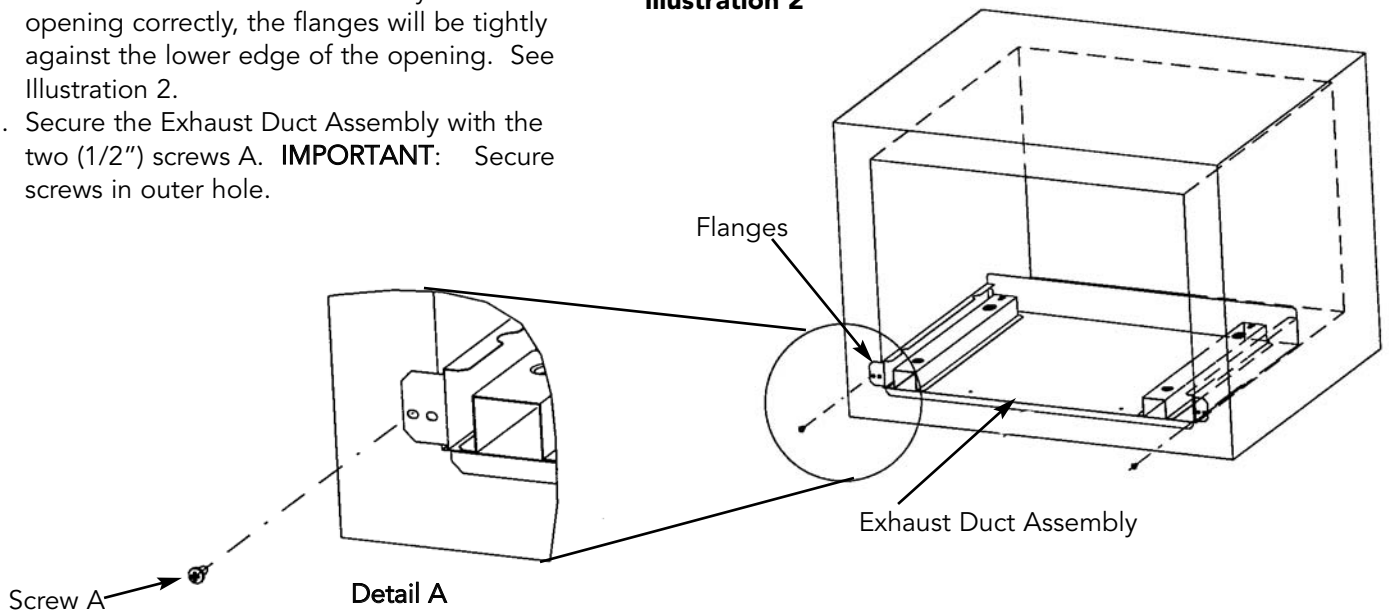

Illustration 1

EXHAUST DUCT ASSEMBLY

1. Place the Exhaust Duct in the opening. When the Exhaust Duct Assembly is in the opening correctly, the flanges will be tightly against the lower edge of the opening. See Illustration 2.
2. Secure the Exhaust Duct Assembly with the two (1/2") screws A. **IMPORTANT:** Secure screws in outer hole.

Illustration 2



FRAME INSTALLATION

1. Place the oven adjacent to the wall or cabinet opening. Plug the power cord into the electrical outlet.
2. Carefully guide the assembled oven into the prepared opening. Slide the oven on the Exhaust Duct Assembly. See Illustration 3. Avoid pinching the cord between the oven and the wall. Adjust the position of the oven so that the feet of the oven are fitted into the recesses of the Exhaust Duct Assembly. See Illustration 4.

Illustration 3

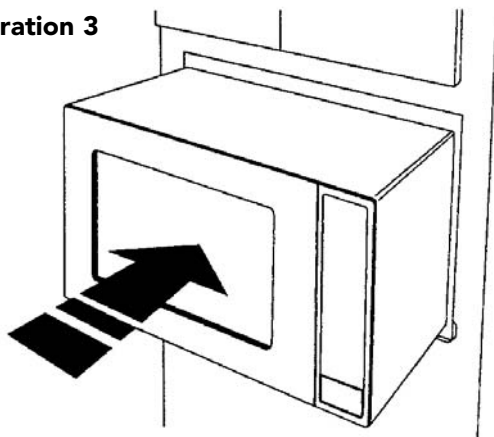
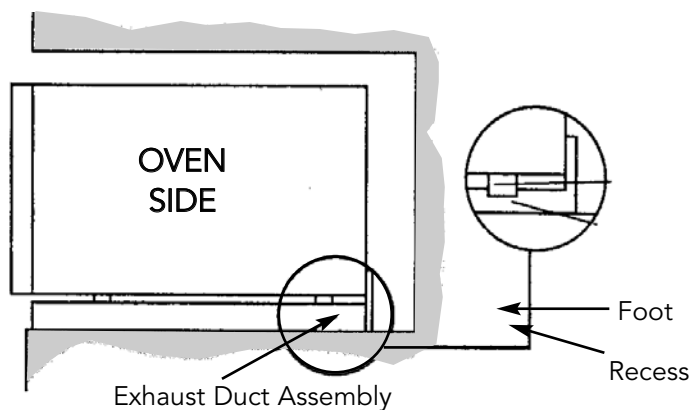

Illustration 4



VMTK ONLY

Position the FRAME ASSEMBLY to be square with the oven. Carefully place the FRAME ASSEMBLY on the oven. Check that it is level and then secure with two SCREWS B. See Illustration 5. Secure the bottom portion of the FRAME ASSEMBLY with the two remaining SCREWS B. See Illustration 5.

Illustration 5

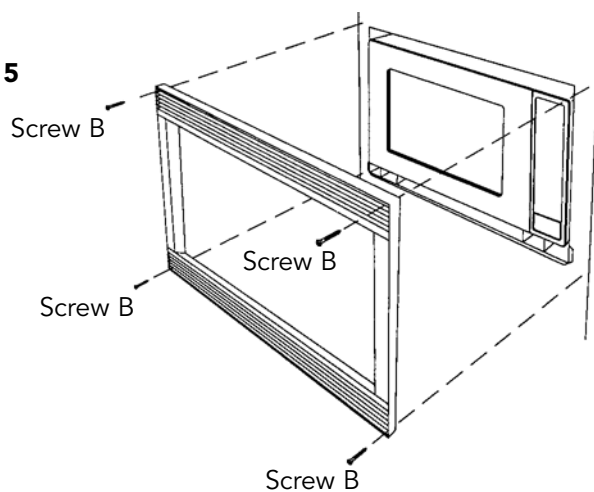

DMTK 27" ONLY

Position the BACK FRAME ASSEMBLY to be square with the oven. Carefully place the BACK FRAME ASSEMBLY on the oven. Check that the oven is level and secure the lower portion FIRST with two of the Screw B. Adjusting the BACK FRAME ASSEMBLY up or down may be necessary in order to locate the thru holes on the exhaust duct assembly. Secure the upper portion of the BACK FRAME ASSEMBLY with the remaining Screw B. See Illustration 5

DMTK 30" ONLY

Position the BACK FRAME ASSEMBLY to be square with the oven. Carefully place the BACK FRAME ASSEMBLY on the oven. Check that the oven is level and secure the upper portion FIRST with two of the Screw B. Secure the bottom portion of the BACK FRAME ASSEMBLY with the remaining two Screws B. See Illustration 5

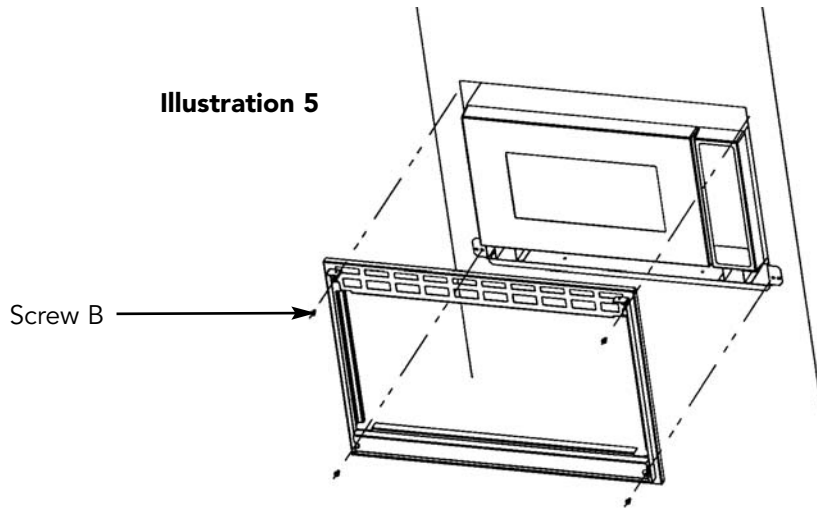

Place the FRONT FRAME ASSEMBLY through the microwave onto the BACK FRAME ASSEMBLY. Secure the FRONT FRAME ASSEMBLY to the BACK FRAME ASSEMBLY with Screws C. See Illustration 6

NOTE: The center tab denotes correct orientation of the FRONT FRAME. See Detail B.

Illustration 6

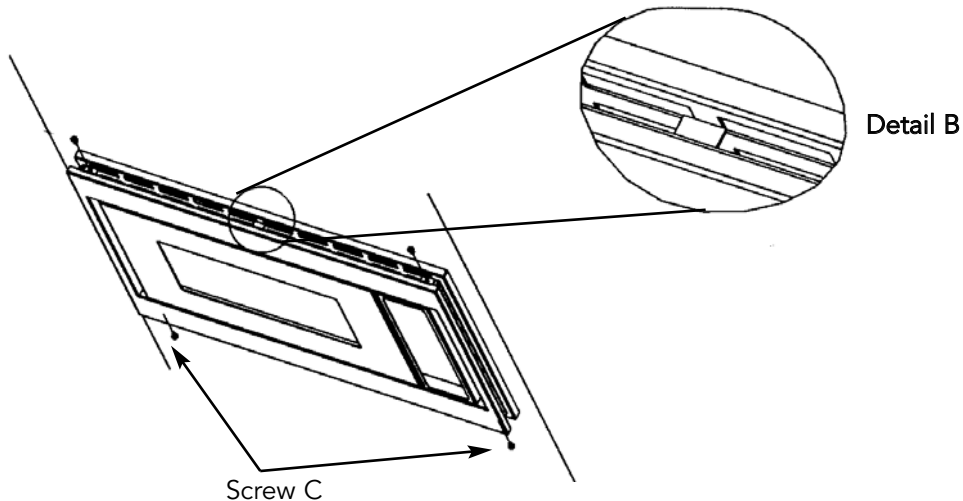

OVER OVEN INSTALLATION

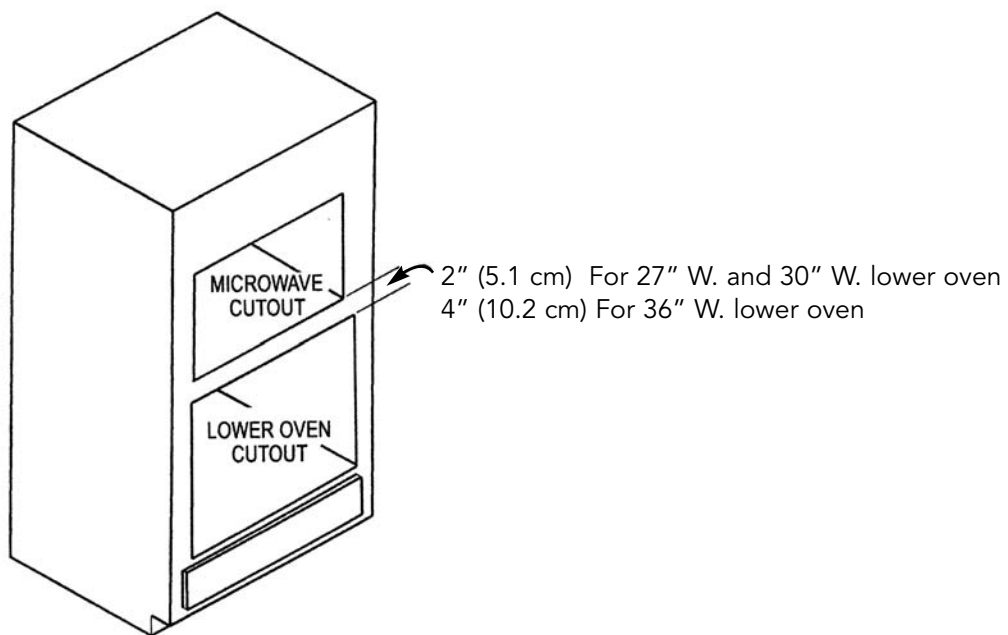

Viking Range Corporation
111 Front Street • Greenwood, Mississippi 38930 USA • (662) 455-1200

Specifications subject to change without notice
For more product information, call 1-888-VIKING1 (845-4641), or visit our web site at <http://www.vikingrange.com>