

## HEIGHT OF INDOOR HOOD

The bottom of the hood should be 30" (76.2 cm) min. to 36" (91.4 cm) max. above the countertop. This would typically result in the bottom of the hood being 66" (167.6 cm) to 72" (182.9 cm) above the floor. The bottom of the hood should never be more than 72" (182.9 cm) above the floor or more than 36" (91.4 cm) above the countertop. These dimensions provide for safe and efficient operation of the hood.

### WALL INSTALLATION

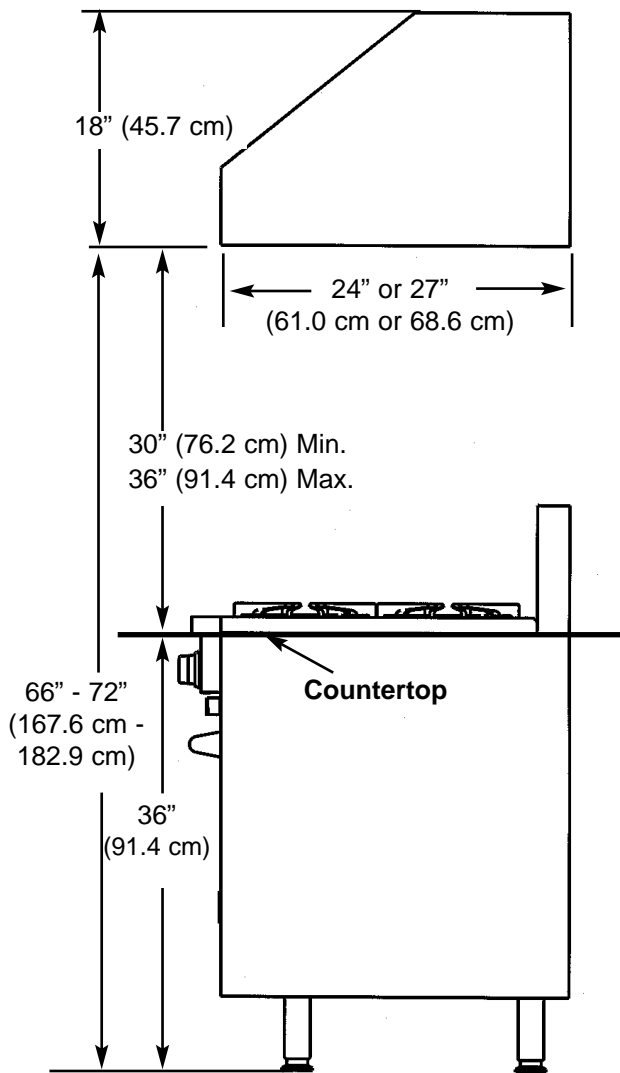

### ISLAND INSTALLATION

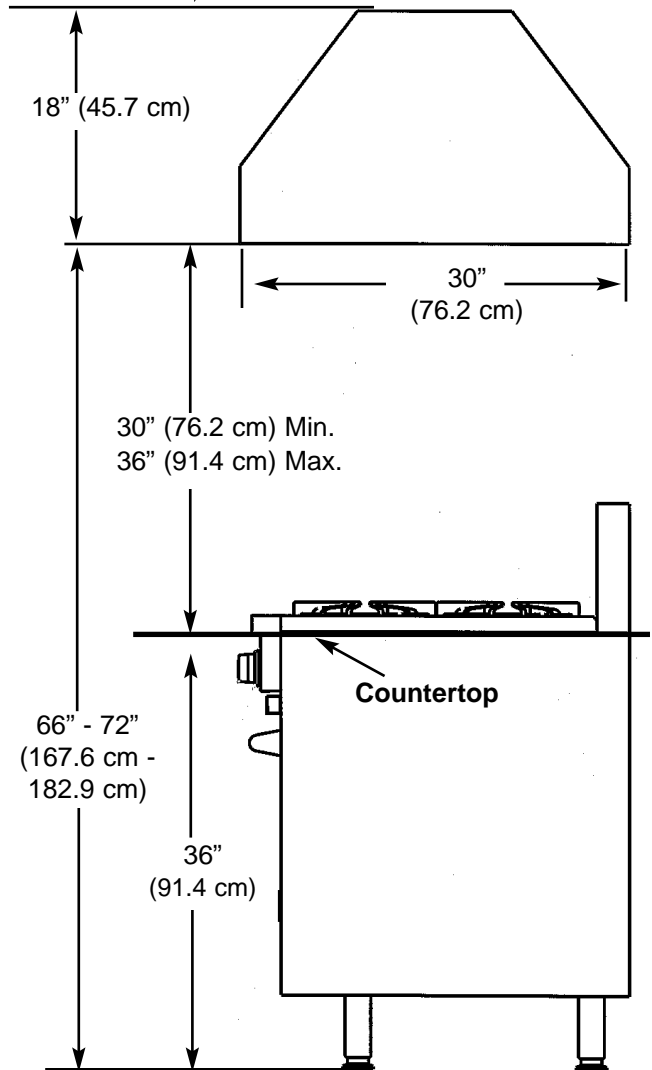

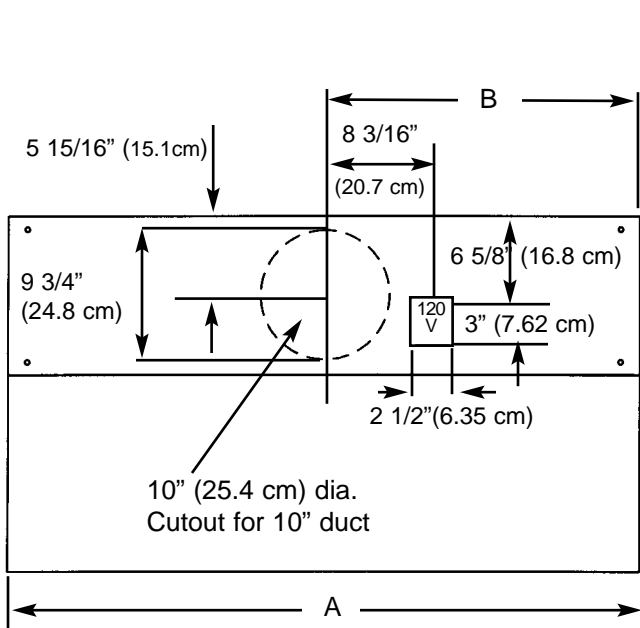

FOR 1200 or 1500 CFM EXTERIOR VENTILATOR INSTALLATION

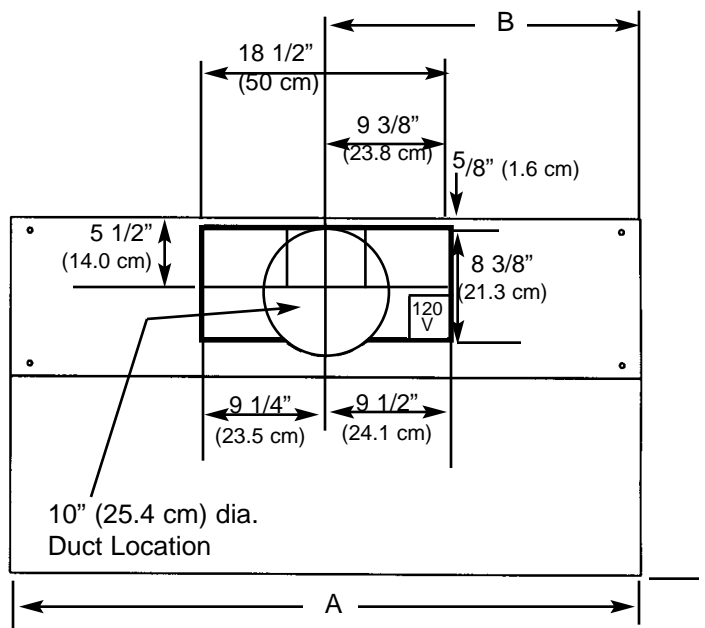

FOR 1200 or 1500 CFM INTERIOR VENTILATOR INSTALLATION

\*Note: "Dotted Line" (.....) represents cutout

	A	B
24" W. Models	23 7/8" (60.6 cm)	11 15/16" (30.3 cm)
30" W. Models	29 7/8" (75.9 cm)	14 15/16" (37.9 cm)
36" W. Models	35 7/8" (91.1 cm)	17 15/16" (45.6 cm)
42" W. Models	41 7/8" (106.4 cm)	20 15/16" (53.0 cm)
48" W. Models	47 7/8" (121.6 cm)	23 15/16" (60.8 cm)
54" W. Models	53 7/8" (136.8 cm)	26 15/16" (68.4 cm)
60" W. Models	59 7/8" (152.1 cm)	29 15/16" (76.0 cm)
66" W. Models	65 7/8" (167.3 cm)	32 15/16" (83.7 cm)

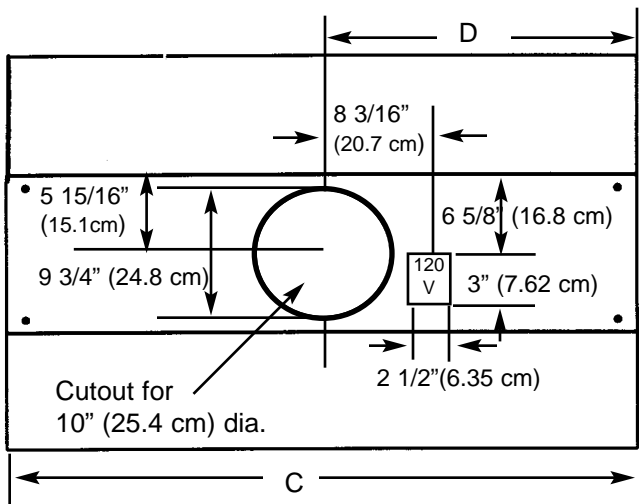

FOR 1200 or 1500 CFM EXTERIOR VENTILATOR INSTALLATION

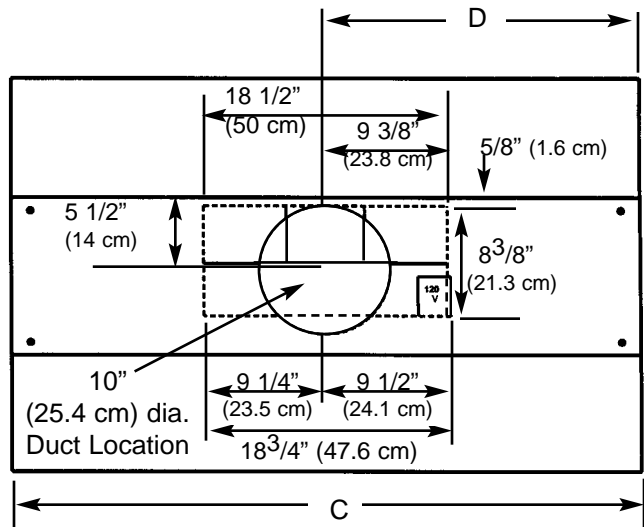

FOR 1200 or 1500 CFM INTERIOR VENTILATOR INSTALLATION

\*Note: "Dotted Line" (.....) represents cutout

	C	D
36" W. Models	35 7/8" (91.1 cm)	17 15/16" (45.56 cm)
42" W. Models	41 7/8" (106.4 cm)	20 15/16" (18.18 cm)
54" W. Models	53 7/8" (136.8 cm)	26 15/16" (68.42 cm)
66" W. Models	65 7/8" (167.3 cm)	32 15/16" (83.66 cm)

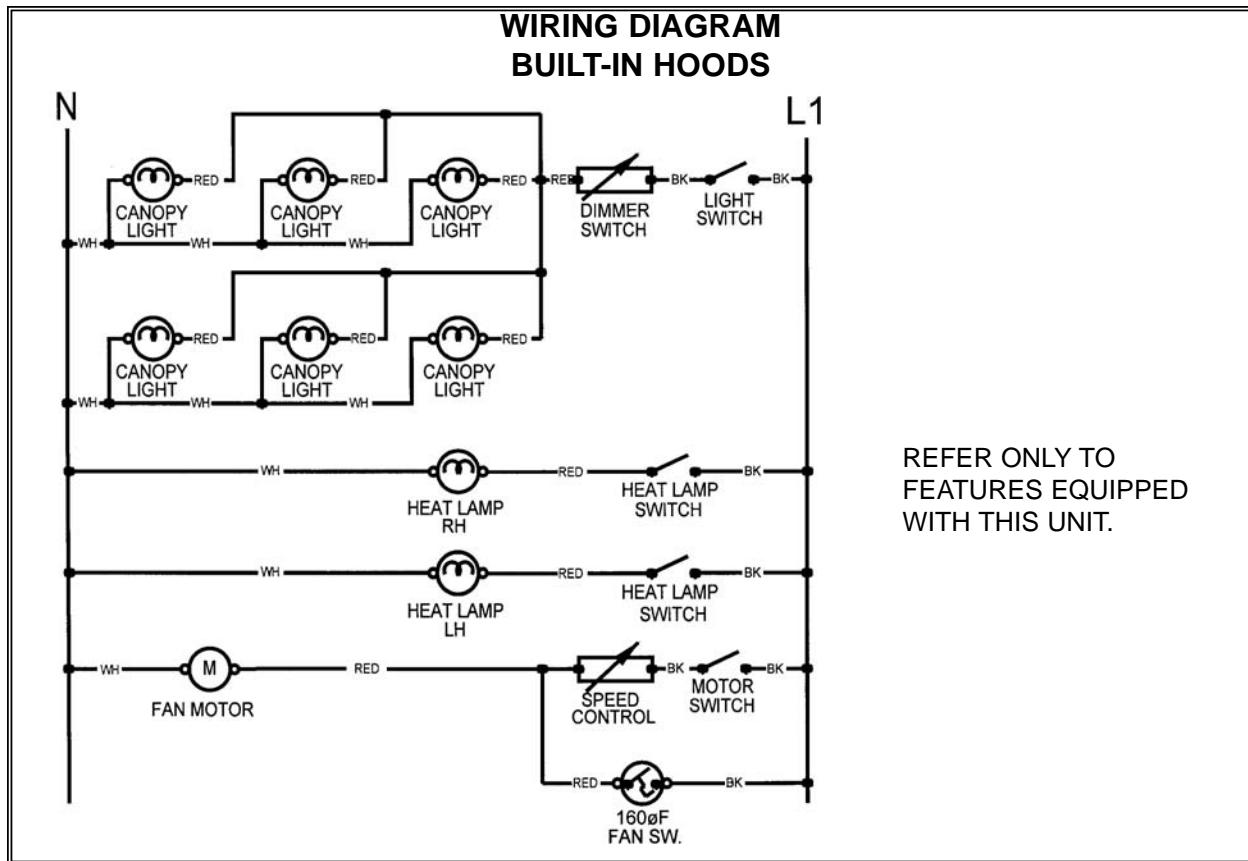

VIKING RANGE CORPORATION

111 Front Street • Greenwood, Mississippi 38930 USA • (662) 455-1200

Specifications subject to change without notice.

For more product information, call 1-888-VIKING1 (845-4641), or visit our web site at <http://www.vikingrange.com>

## BASIC SPECIFICATIONS - INTERIOR AND EXTERIOR POWER HOODS

### 18" H. Indoor Wall Hoods

DESCRIPTION	RECOM. CFM <sup>1</sup>  (Int.-Interior; Ext.-Exterior)	NUMBER OF HALOGEN LIGHTS	250 WATT HEAT LAMPS (bulb sold separately)	FILTERS	SPACERS	120VAC/60Hz MAX. AMPS <sup>3</sup>  (Interior/Exterior)
24"W.	300 int./600 int./900 ext./1200 ext.	2	1	2	1	5.0/6.2/8.7/6.1
30" W.	300 int./600 int./1200 int./900 ext./1200 ext.	2	1	2	1	5.0/6.2/8.7/8.7/6.1
36"W.*	300 int./600 int./1200 int./900 ext./1200 ext.	2	1	2	2	5.0/6.2/8.7/8.7/6.1
42"W.*	600 int./1200 int./900 ext./1200 ext.	2	1	2	2	6.2/8.7/8.7/6.1
48"W., 54"W.*	1200 int./1200 ext./1500 ext.	3	2	3	2	11.1/8.4/9.1
60"W.*	1200 int./1200 ext./1500 ext.	4	2	4	1	11.5/8.8/9.5
66"W.*	1200 int./1200 ext./1500 ext.	4	2	4	2	11.5/8.8/9.5

### 18" H. Island Hoods

DESCRIPTION	RECOM. CFM <sup>1</sup>  (Int.-Interior; Ext.-Exterior)	NUMBER OF HALOGEN LIGHTS	FILTERS	SPACERS	120VAC/60Hz MAX. AMPS <sup>3</sup>  (Interior/Exterior)
36"W.*	600 int./1200 int./900 ext./1200 ext.	4	4	2	4.9/7.4/7.4/4.7
42"W.*	600 int./900 ext./1200 ext./1500 ext.	4	4	4	4.9/7.4/4.8/5.4
54"W.*	1200 int./1200 ext./1500 ext.	6	6	4	8.2/5.6/6.2
66"W.*	1200 int./1200 ext./1500 ext.	8	8	4	9.0/6.3/7.1

### 18" H. Outdoor Wall Hoods\*

DESCRIPTION	RECOM. CFM <sup>1</sup>  (Int.-Interior; Ext.-Exterior)	NUMBER OF HALOGEN LIGHTS	FILTERS	SPACERS	120VAC/60Hz MAX. AMPS <sup>3</sup>  (Interior/Exterior)
36"W.	1200 int./1200 ext./1500 ext.	2	2	2	8.7/6.1/6.8
48"W.	1200 int./1200 ext./1500 ext.	3	3	2	11.5/8.8/9.5
60"W.	1200 int./1200 ext./1500 ext.	4	4	1	11.5/8.8/9.5

\*1200 CFM interior or exterior or 1500 CFM exterior (if applicable) ventilator should be used with all outdoor approved models and when indoor models are installed over ranges/rangetops with gas grill.

MODEL NUMBER	CFM <sup>1</sup>	RECOMMENDED DUCT SIZE	MAX. DUCT RUN <sup>2</sup> (ft.)
<b>For Use with hoods:</b>			
VIV300 (interior)	300	7" round	50
VIV600 (interior)	600	7" round	50
VIV1200 (interior)	1200	10" round	50
VEV900 (exterior)	900	10" round	50
VEV1200 (exterior)	1200	10" round	50
VEV1500 (exterior)	1500	10" round	75

### **PROPER INSTALLATION/DUCTING IS EXTREMELY IMPORTANT TO ENSURE MAXIMUM PERFORMANCE FROM ANY VENTILATION PRODUCT**

- All CFMs stated are based on tests at .1 static pressure: without applying static pressure, CFM would be greatly overstated.
- Duct run length is for general reference only; for longer duct runs, increase duct size and contact a qualified and trained installer.
  - Straight runs and gradual turns are best; for example, each 90° elbow is equivalent to 5-10 feet (1.52 - 3.05 cm) of straight run.
  - Never use flexible duct; it creates back pressure/air turbulence and greatly reduces performance.
  - Proper performance is dependent upon proper ducting; make sure that a qualified and trained installer is used.
  - Check with a qualified and trained installer or local codes for makeup air requirement, if any.**
- Max. amp rating for hoods includes recommended ventilator kit rating; all products must be hard wired direct with 2-wire with ground.