

## GENERAL INFORMATION

### UNPACK

1. Remove banding from bottom of carton. Lift carton up and off of the unit.
2. Remove all tape and packaging material from the outside and inside of the cabinet.
3. Keep all carton packaging until your wine cooler has been thoroughly inspected and found to be in good condition.

### AREA REQUIREMENTS

1. Place unit so the front side will be completely unobstructed to provide proper air flow. The unit may be closed in on the top and three sides, but the front **MUST BE** unobstructed for air circulation and proper operation. Installation should be such that the cabinet can be moved for servicing if necessary.
2. Unit should be in a well ventilated area. Best results are obtained at temperatures between 65°F (18°C) and 80°F (27°C) for built-in models and 65°F (18°C) and 90°F (30°C) for freestanding models.
3. Provisions for electricity should be determined before placing unit in proper place.

## UNDERCOUNTER CABINET CUTOUT

<b>A</b>	24" (61.0 cm)*
<b>B</b>	Min. 34 1/8" (86.7 cm) Max. 35 1/8" (89.2 cm)
<b>C</b>	24" (61.0 cm)

\*24" width for cabinet only. If door is recessed between cabinets, cabinet cutout must be 24-1/4" (61.6 cm)

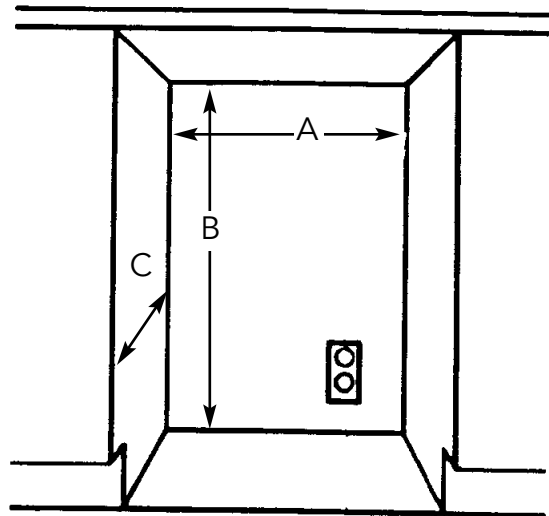

## SPECIFICATIONS/DIMENSIONS

### Basic Electric Data

- 115 VAC/60 Hz
- Maximum amps - 3.3
- Approximate Shipping Weight - 140 lbs. (63.2 kg)

Side View  
DUAR

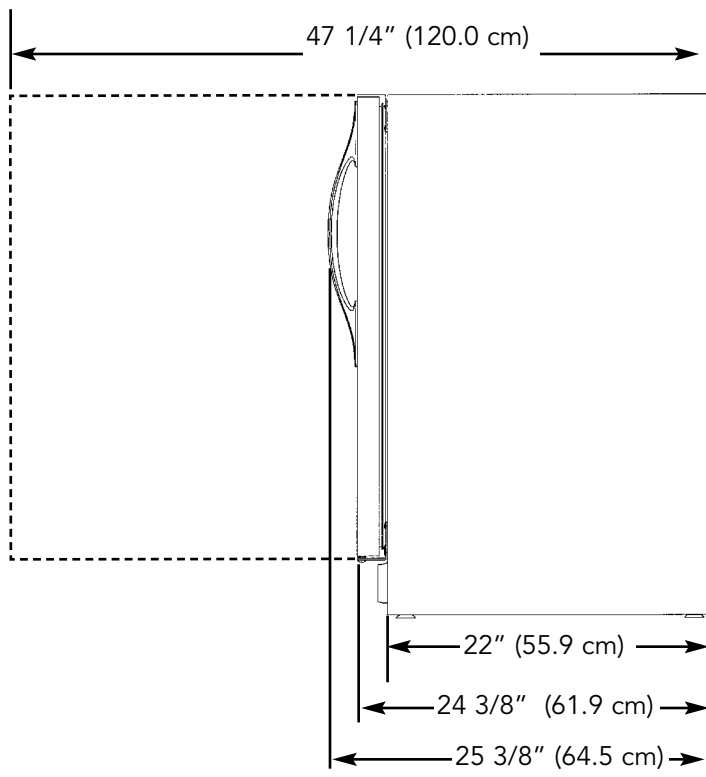

Front View

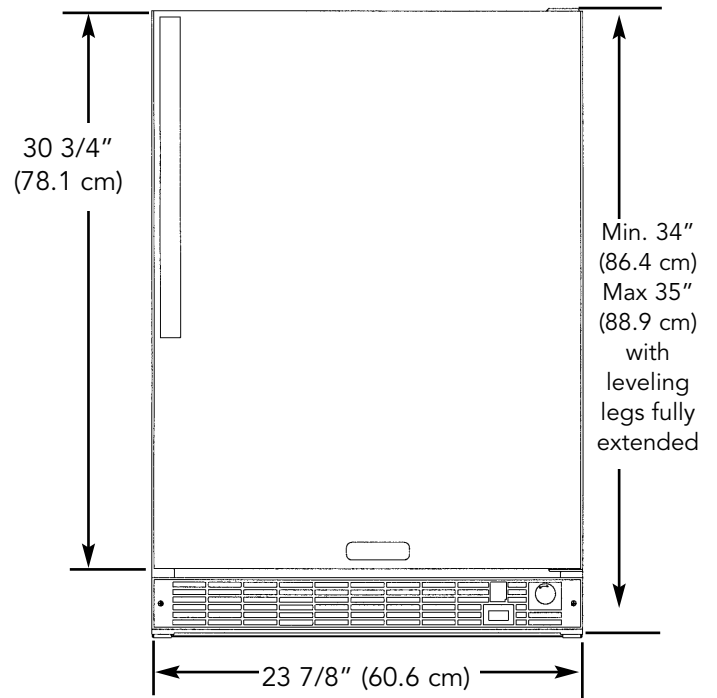

Side View  
DFUR

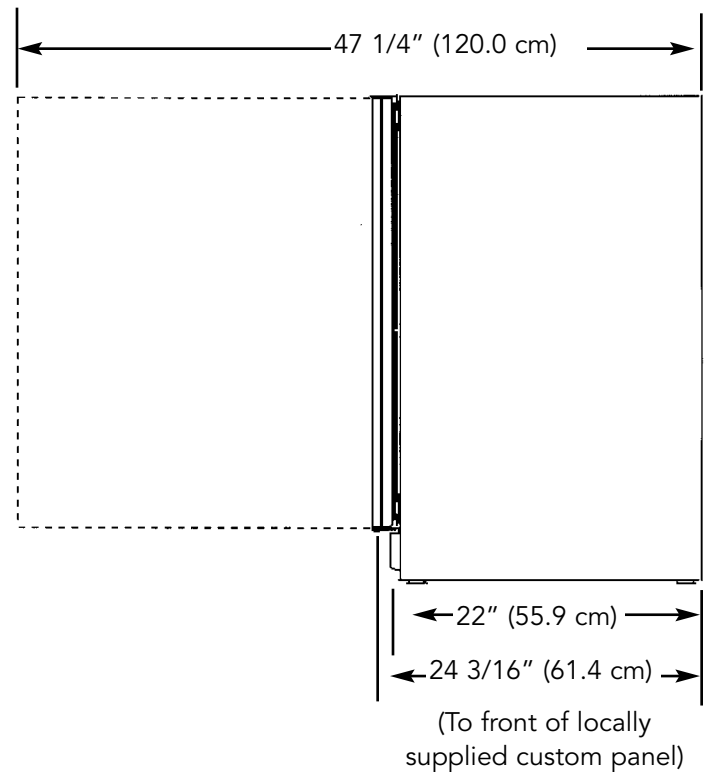

# CUSTOM WOOD FRAME INSTALLATION INSTRUCTIONS

## (DFUR Models)

**NOTE:** Weight of wood panel must not exceed 20 lbs.

### Wood Screws

1. A #8 pan head wood screw should be used to properly secure the wood frame. A total of 10 screws will be needed for a 3 1/2" (8.9 cm) kickplate or 8 screws for a 4" (10.2 cm) kickplate.
2. Only use pan head screws.
3. **DO NOT** select a screw that is longer than the wood thickness at the screw locations.
4. Use recommended pilot holes for the frame material. (See chart)

Working Material	Wood Screw Size - #8
Hardwood	3/32 (0.24 cm)
Softwood	5/64 (0.20 cm)

### Assembling Door Hinge Brackets

(Disregard if hinge brackets are already attached)

1. Attach the top and bottom door hinge brackets to the door with the #10-32 machine screws and a 1/8" allen head driver as shown in Figure 1 below.
2. Press in the shoulder bushings to the top and bottom door hinge brackets. Make certain that the shoulder is to the outside of the door as shown in Figure 1 below.
3. Test fit the door to the unit to make certain door will hang correctly. The door is hung correctly when the top of the door is parallel to the top of the unit. (See Figure 2) Adjustments can be made by loosening the door hinge machine screws and moving the door hinge brackets on the door.
4. Tighten all four (4) machine screws after adjustments have been made.
5. Remove the door from the unit by removing the units top hinge set screw and angling the door off of the bottom hinge pin.

Figure 1

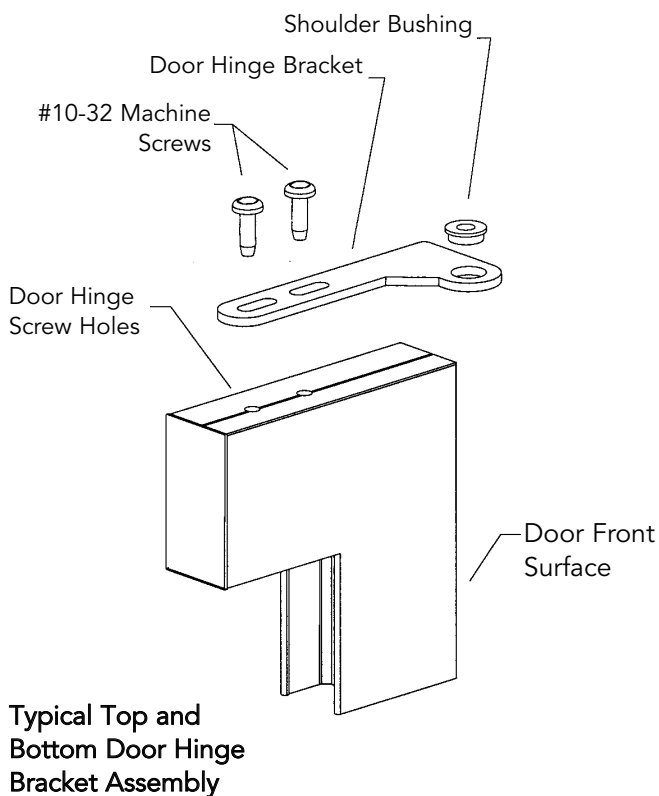
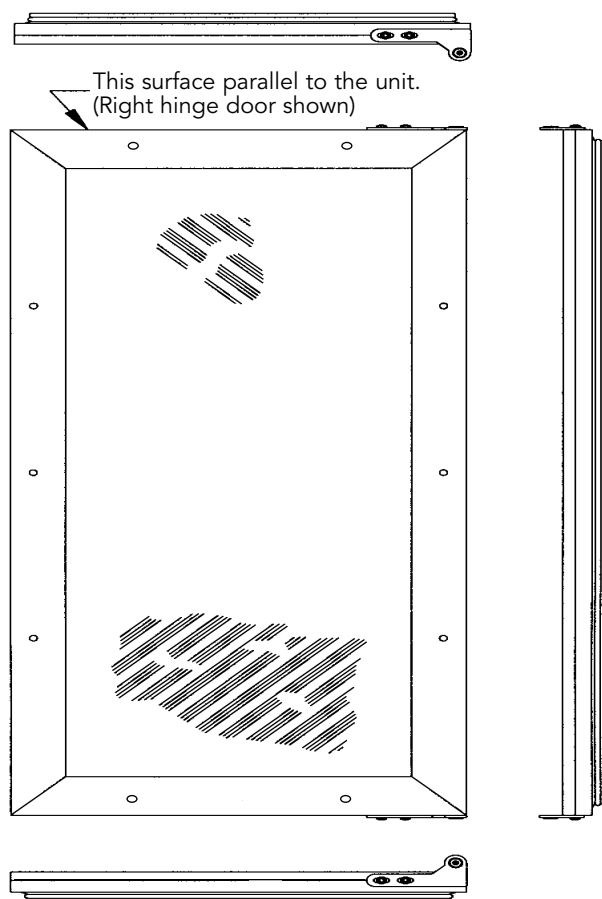
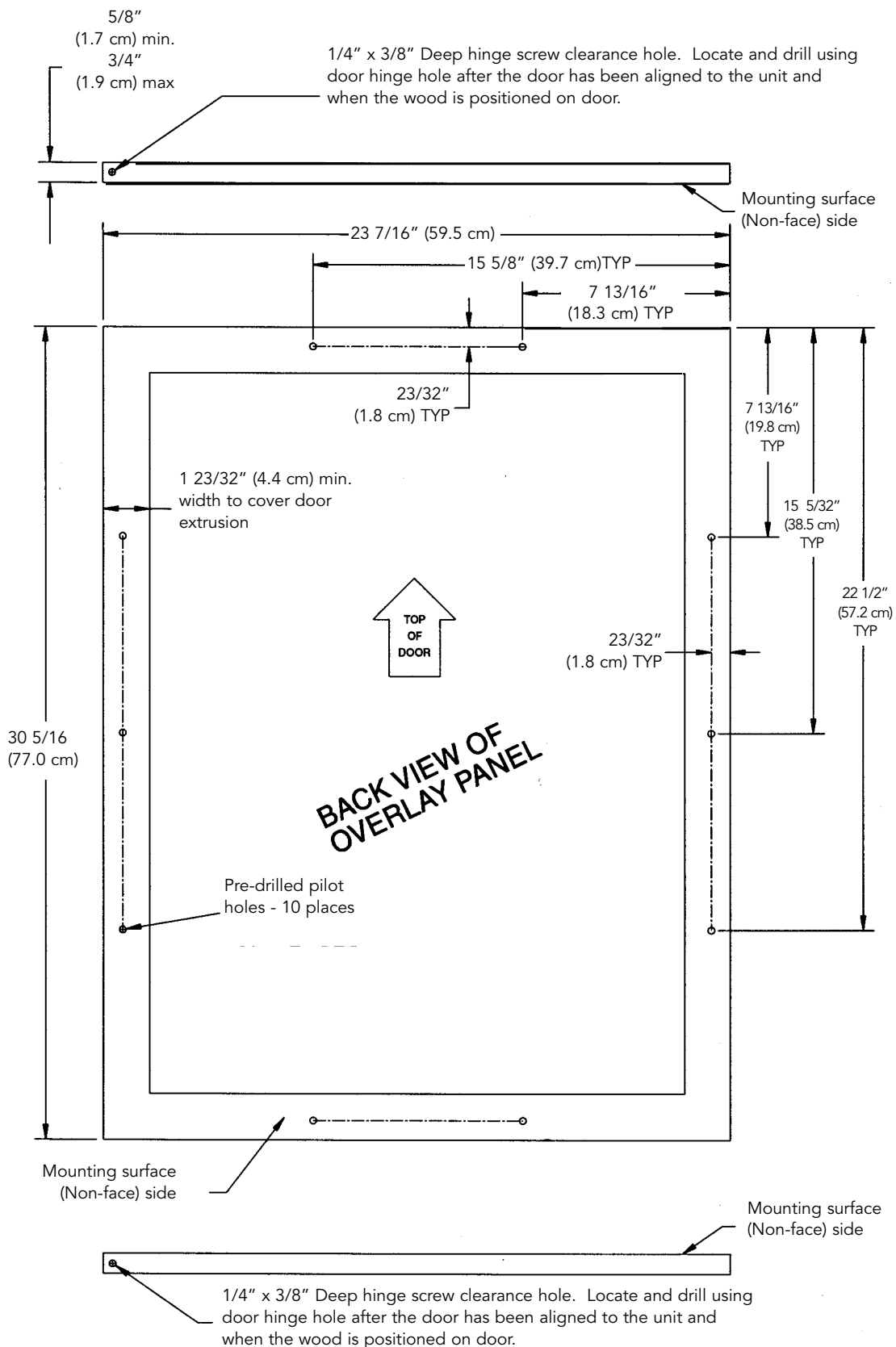

Figure 2



# Selecting and Preparing the Wood Frame

## FOR 3-1/2" TOE KICK (COVERS THE ENTIRE DOOR EXTRUSION)



## OPTIONAL FOR 4" TOE KICK TO MATCH EXISTING CABINETRY TOE KICK HEIGHT

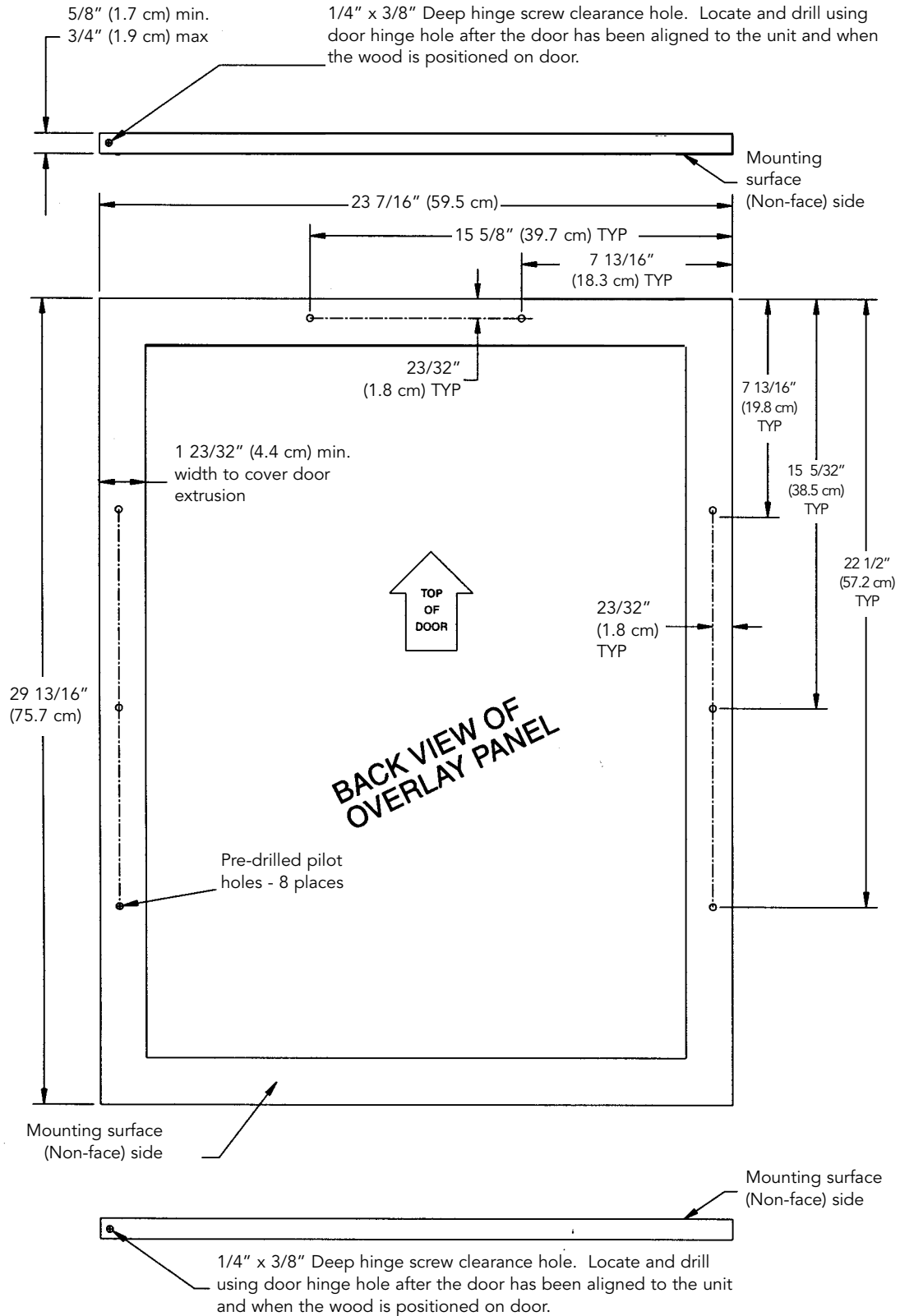

### Attaching the Handle

Attach the handle of your choice by drilling mounting holes through panel. Countersink or counterbore holes from back side of panel for handle screw heads to be flush.

## Attaching the Wood Frame to the Door

1. If the door is attached to the unit, remove by unscrewing the top allen head set screw at the top hinge. Remove the door by angling the door off of the bottom hinge pin.
2. Peel back the door gasket to expose the screw holes.
3. Set the wood frame flush to the front of the door in the desired location. Clamp the wood frame to the door if necessary.
4. Insert the wood screws through the back of the door into the pilot holes in the wood frame and tighten.
5. Reinstall the door gasket by pressing into the door channel. Make certain the corners are inserted fully.
6. Install the door to the unit. Use the supplied plastic washer as shown in the figure below.
7. Realigning the door may be necessary. Any final door adjustments can be made using a 1/8" allen head driver to adjust the door's hinges. (See figure below)
8. Attach the door light striker plate as shown using the 5/16" hex or phillips head screws provided. Make certain the light is able to turn on and off when the door is opened and closed.
9. Attach the door to the unit by reversing step number 1 above.

