

## DFWD CABINET CUTOUT

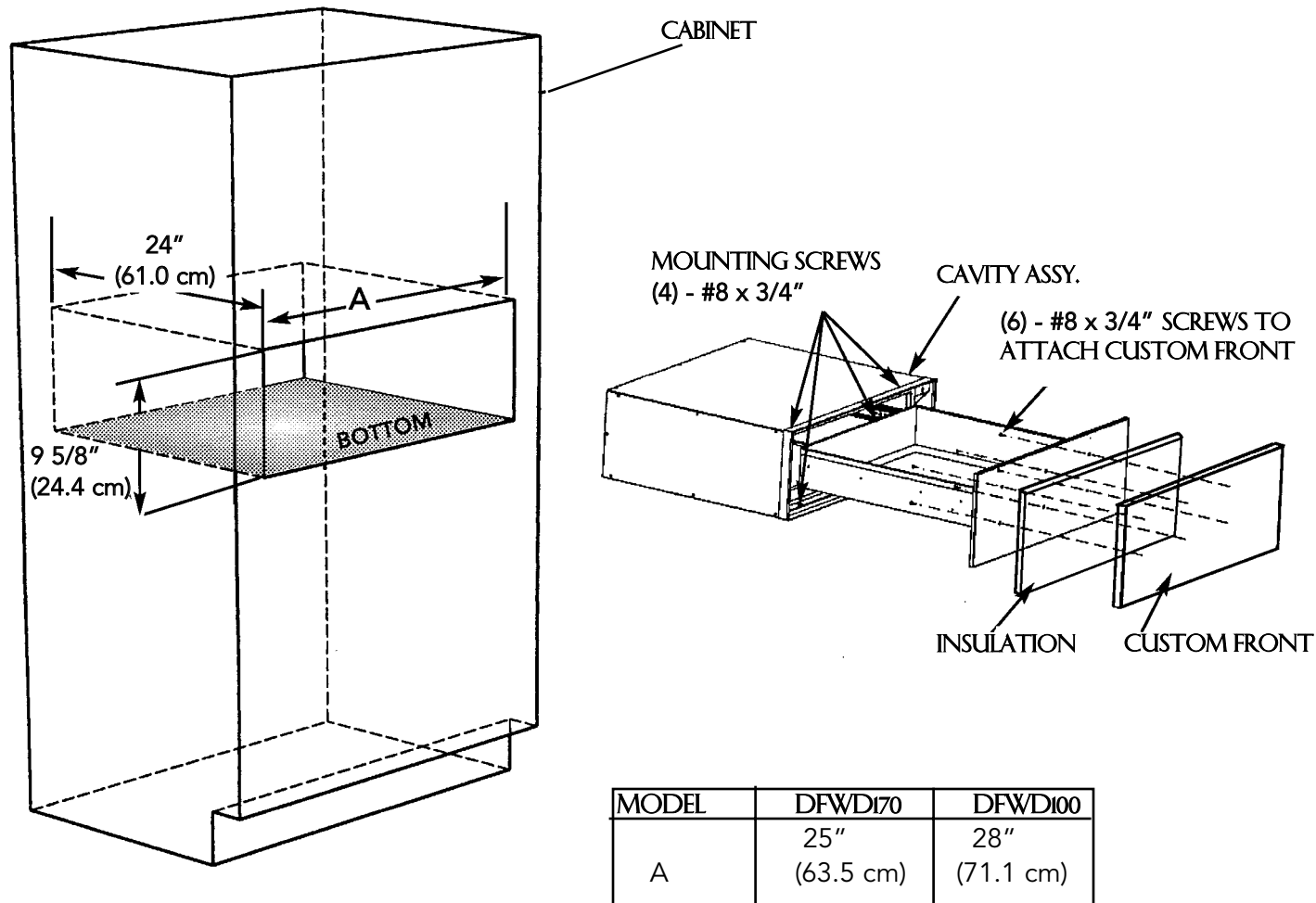

## CUSTOM FRONT INSTALLATION

- Open the drawer and remove the pan.
- Center the custom front and insulation around the inside panel.
- \*NOTE: Make sure the insulation provided is used between the custom panel and the inside door panel.**
- Attach the custom front with the (6) six #8 x 3/4" screws provided.

## CABINET INSTALLATION

- To remove drawer assembly, pull warming drawer pan out until fully extended. Slide finger along the right and left side until you reach the black hand latches (located at the front of the rails). Pull up on both the right and left latches and pull drawer pan support completely out.
- Slide cavity assembly into cabinet opening.
- Drill (4) pilot holes in cabinet using 1/8" drill bit. Permanently secure the warming drawer using the (4) #8 mounting screws provided.
- Replace drawer assembly.

# CUSTOM PANEL DIMENSIONS

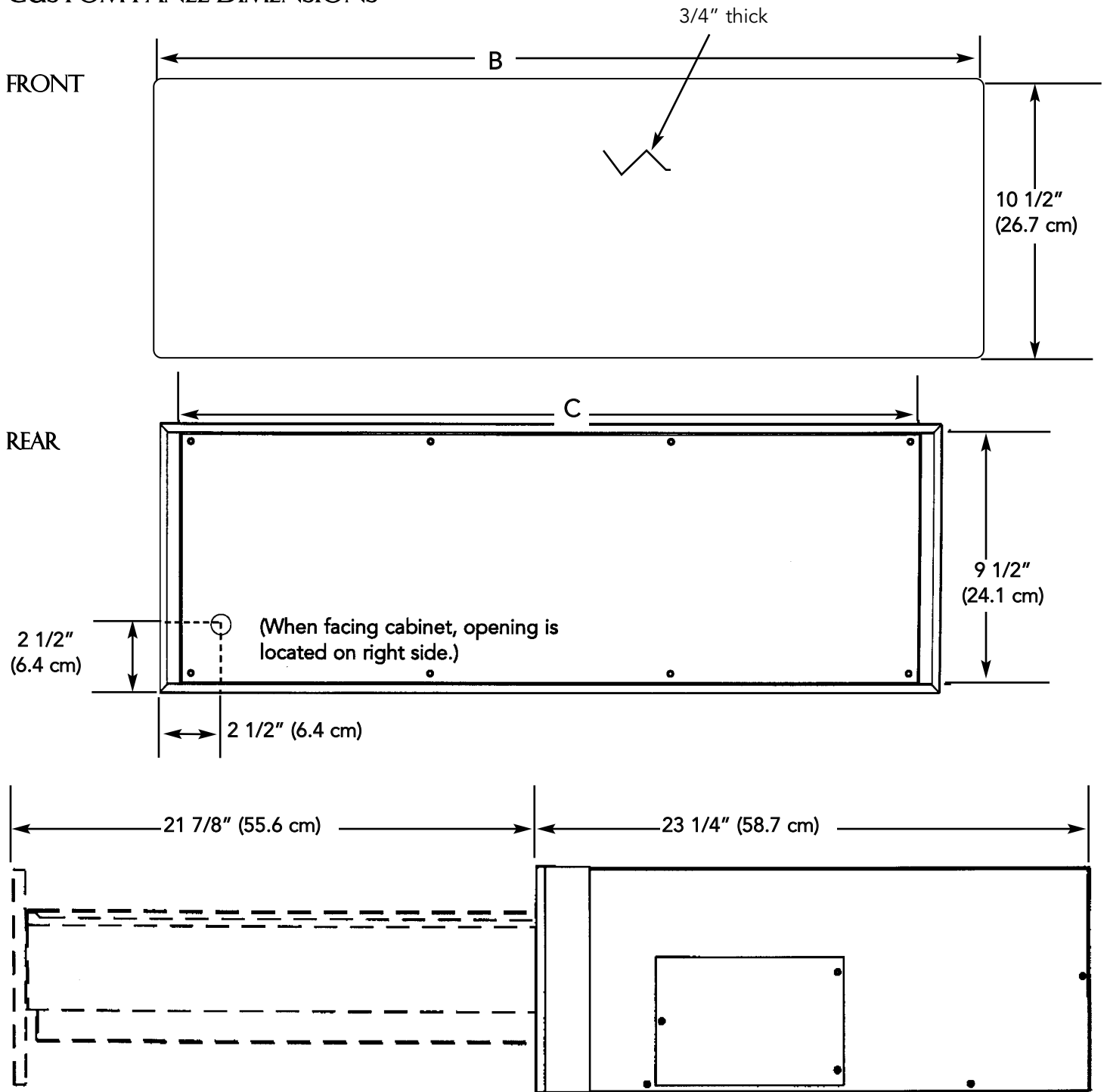

MODEL	DFWDI70	DFWDI00
B	26" (66.0 cm)	29" (73.7 cm)
C	24 7/8" (63.2 cm)	27 7/8" (70.8 cm)
Interior width	18 7/8 (47.9 cm)	21 7/8" (55.6 cm)
Interior height	5 7/16" (13.8 cm)	5 7/16" (13.8 cm)
Interior depth	21 3/16" (53.8 cm)	21 3/16" (53.8 cm)
Approx. shipping Weight	75 lb. (33.7 kg)	90 lb. (40.5 kg)