

ICE MACHINE – DIMENSIONS 15" WIDTH

Front

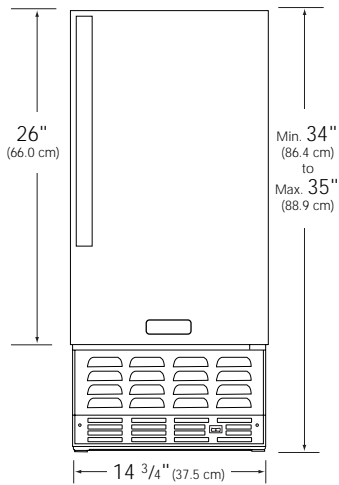

Side

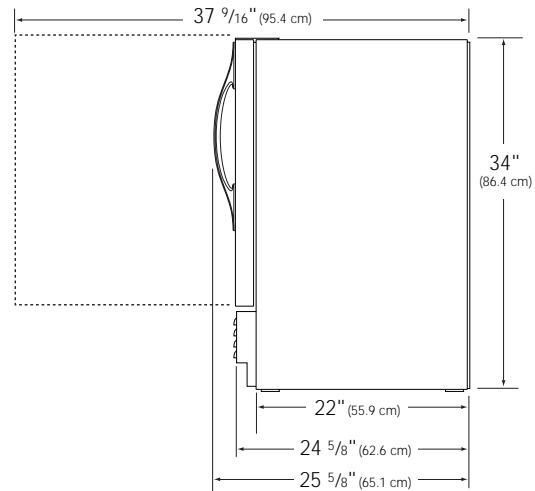

Undercounter Cutout

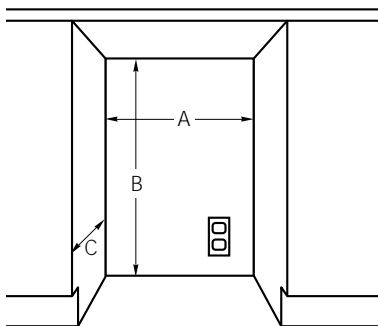

UNDERCOUNTER CUTOUT

A	15" (38.1 cm)*
B	Min. 34 1/8" (86.7 cm) Max. 35 1/8" (89.2 cm)
C	24" (61.0 cm)

* 15" (38.1 cm) width for cabinet only;
If door is recessed between cabinets, cutout
must be 15 1/4" (38.7 cm).

BASIC SPECIFICATIONS

Description	D U I M 1 5 0
Overall Width	14 3/4" (37.5 cm)
Overall Height from Bottom	Min. 34" (86.4 cm) Max. 35" (88.9 cm) (legs fully extended)
Overall Depth from Rear	25 5/8" (65.1 cm) (to edge of handle)
Cutout Width	15" (38.1 cm)*
Cutout Height	Min. 34 1/8" (86.7 cm) Max. 35 1/8" (89.2 cm)
Cutout Depth	24" (61.0 cm)
Electrical Requirements	115VAC/60Hz
Maximum Amp Usage	3.0 amps
Maximum Storage Capacity	3.0 cu. ft.
Approximate Shipping Weight	110 lb. (49.5 kg)

* 15" (38.1 cm) width for cabinet only; If door is recessed between cabinets, cutout must be 15 1/4" (38.7 cm).