

TRASH COMPACTOR – DIMENSIONS

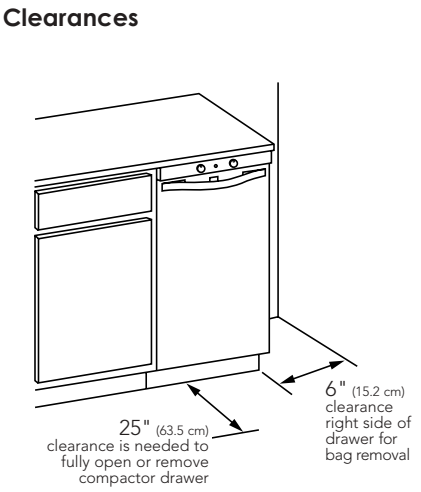
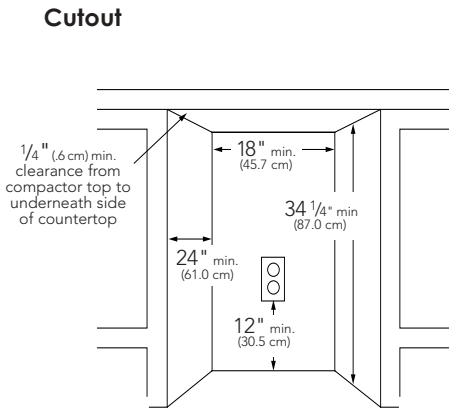
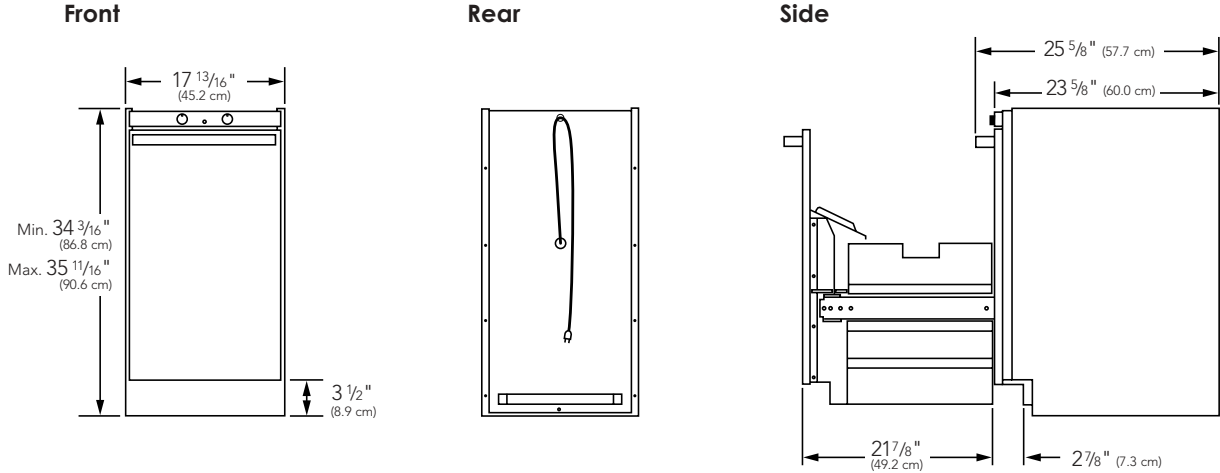

BASIC SPECIFICATIONS

Description	DUC180
Overall Width	17 13/16" (45.2 cm)
Overall Height from Bottom	Minimum – 34 1/8" (86.7 cm) Maximum – 35 1/2" (90.2 cm)
Overall Depth from Rear	To edge of side – 23 7/8" (60.6 cm) To front edge of handle – 25 7/8" (65.7 cm) With door open – 47" (119.4 cm)
Cutout Width	18" (45.7 cm)
Cutout Height	Minimum – 34 1/4" (87.0 cm) Maximum – 35 5/8" (90.5 cm)
Cutout Depth	24" (61.0 cm)
Electrical Requirements	115VAC/60Hz; 72" (128.9 cm) 2-wire cord with grounded 3-prong plug attached to product
Maximum Amp Usage	9.0 amps
Approximate Shipping Weight	217 lb. (97.7 kg)