

# Inca Pro 38

a fusion of power and style

BUILT-IN  
PRO SERIES

- o professional-style insert
- o fits custom hoods 40" wide and up
- o stainless steel finish
- o 1100 cfm PRO motor combo
- o 3 halogen lights
- o 3 speed control
- o integrated control panel
- o stainless steel baffle filters
- o convertible to recirculating\*
- o built-in mounting system
- o sloped front and sides
- o some range: 3.5 - 6.5
- o 2 - 6" round ducts



\*it is highly recommended that professional style cooking always be vented to the outside.



*Finally, a high-powered insert that looks as great as it performs. The Inca Pro 38, with its powerful PRO motor combo and stylish baffle filter system, offers an all-in-one-box solution for custom ventilating.*

Size/Color/Model #

38 Stainless 630001175

a  
c  
c  
e  
s  
s  
o  
r  
i  
e  
s

Inca Pro 38 can be used with custom hoods 40" wide and up. Choose either a custom liner or our ProLiner designed for 42" and 48" wide installations.

### Liners

Create a perfectly-sealed, non-combustible perimeter around the Inca Pro. Depth adjustable from 21" - 25".

- ProLiner 42 Stainless 620000302
- ProLiner 48 Stainless 620000303



### Duct Transition Kit

Transitions two 6" round openings to one 10" round opening (optional)

Galvanized Steel 620000087

**Charcoal Filters** 6093034  
(Order 2 Kits)

For recirculating installations, high quality, heavy duty filters ensure the removal of smoke and odors from the kitchen. Some ductwork is required to exhaust the unit out of the cabinet. YOU MUST ORDER TWO OF PART #6093034 (ONE KIT FOR EACH OF THE TWO INCA PRO MOTORS)

## Dimensional Diagrams

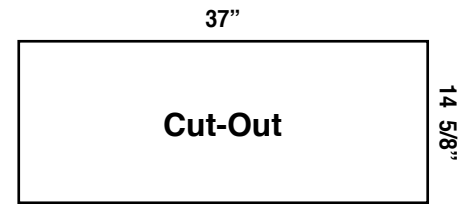
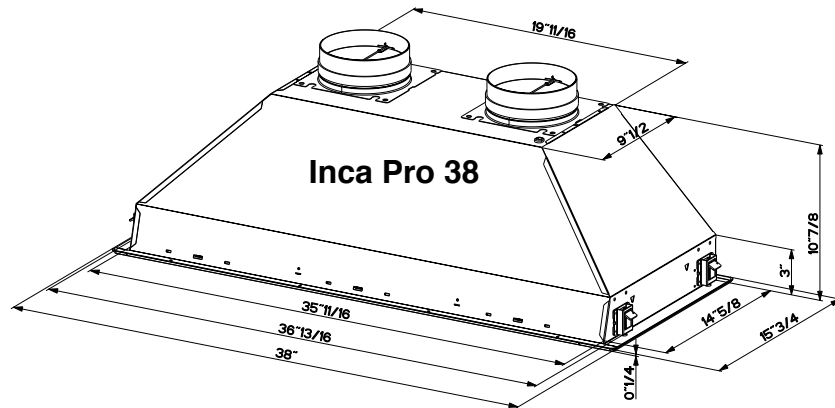

## Liners

Create a perfectly-sealed, non-combustible perimeter around the Inca Pro 38. Designed for 42" and 48" wide installations. Depth adjustable from 21" - 25"

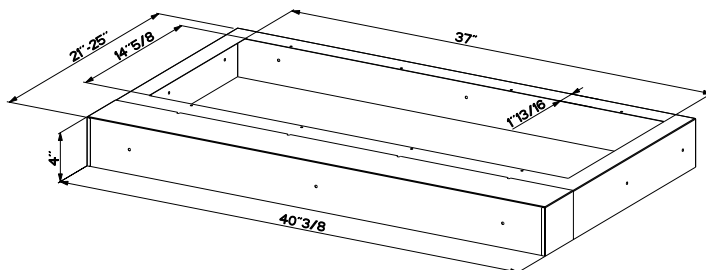

**ProLiner 42 Stainless (620000302)**  
designed for 42" wide installations

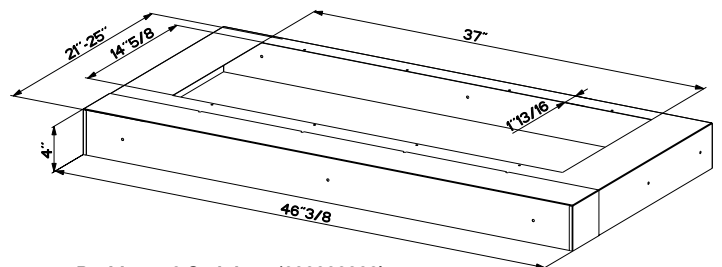

**ProLiner 48 Stainless (620000303)**  
designed for 48" wide installations

## Optional Duct Transition Kit

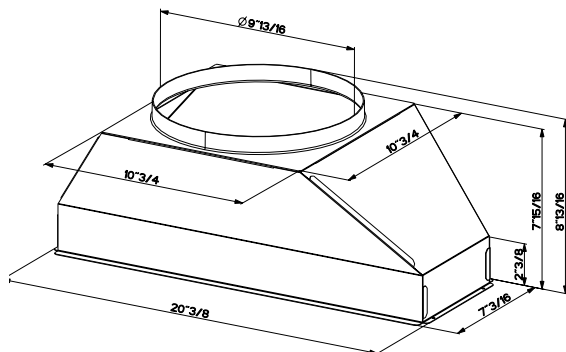

**Pre-Planning Your Ductwork - Important:** Consult the installation instructions before you begin installing this rangehood.

Use two 6" round duct runs or use the optional **Duct Transition Kit** shown above which merges the two 6" ducts into one 10" round duct run.

The ductrun should not exceed 35 equivalent feet if ducted using two separate duct runs of the required minimum of 6" round duct or 55 equivalent feet if ducted with one single 10" round duct (when using optional **Duct Transition Kit**). Count 45° angles as 3 feet, 90° elbows as 5 feet, and 90° flat elbows as 12 feet.

**For best results, use no more than three 90° elbows. Make sure that there is a minimum of 24" of straight duct between elbows if more than one is used. Do not install two elbows together. If you must elbow right away, do it as far away from the hood's exhaust opening as possible.**

**WARNING!** Product specifications are subject to change without notification. Consult the installation instructions before you begin installing this rangehood.

## Recirculating Installations

IT IS HIGHLY RECOMMENDED THAT PROFESSIONAL STYLE COOKING ALWAYS BE VENTED TO THE OUTSIDE. For installations where ductwork is impossible or highly impractical **Charcoal Filters**, which attach to the blower assembly, absorb smoke and odors.

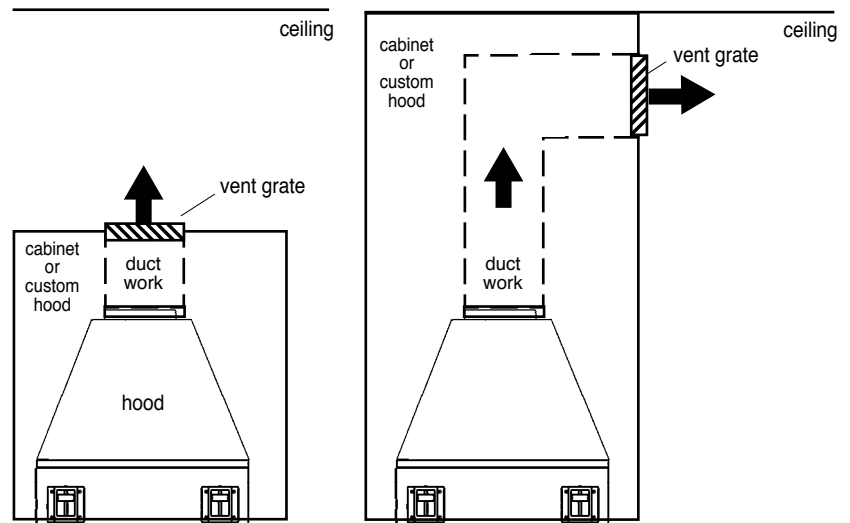

**Some ductwork must be installed** to exhaust the rangehood back into the kitchen either at the top or face of the cabinet or wood hood. This duct work must not terminate into a dead air space or inside the cabinet or custom hood.