

## SPECS / DIMENSIONS



### CIT302DS

### 30" HYBRID™ ELECTRIC/INDUCTION COOKTOP WITH 2 INDUCTION ZONES AND 2 ELECTRIC RADIANTS (UPPER AND LOWER LEFT ELEMENTS)

PRINT

#### GENERAL INFORMATION

Approximate Shipping Weight (in lbs.)	35
Front Left Element (in kW)	1.4
Front Right Element (in kW)	2.2/3.3
Rear Left Element (in kW)	.75/2.2
Rear Right Element (in kW)	1.4/1.8
Center Element (in kW)	N/A

#### DIMENSIONS (INCHES)

Overall Dimensions - A	31
Overall Dimensions - B	21
Overall Dimensions - C	3 5/8
Overall Dimensions - D	28 3/4-28 7/8
Overall Dimensions - E	19 7/8-20
Front Left Element (in mm.)	145
Front Right Element (in mm.)	210
Rear Left Element (in mm.)	120/210
Rear Right Element (in mm.)	150
Center Element (in mm.)	N/A

#### Diagrams

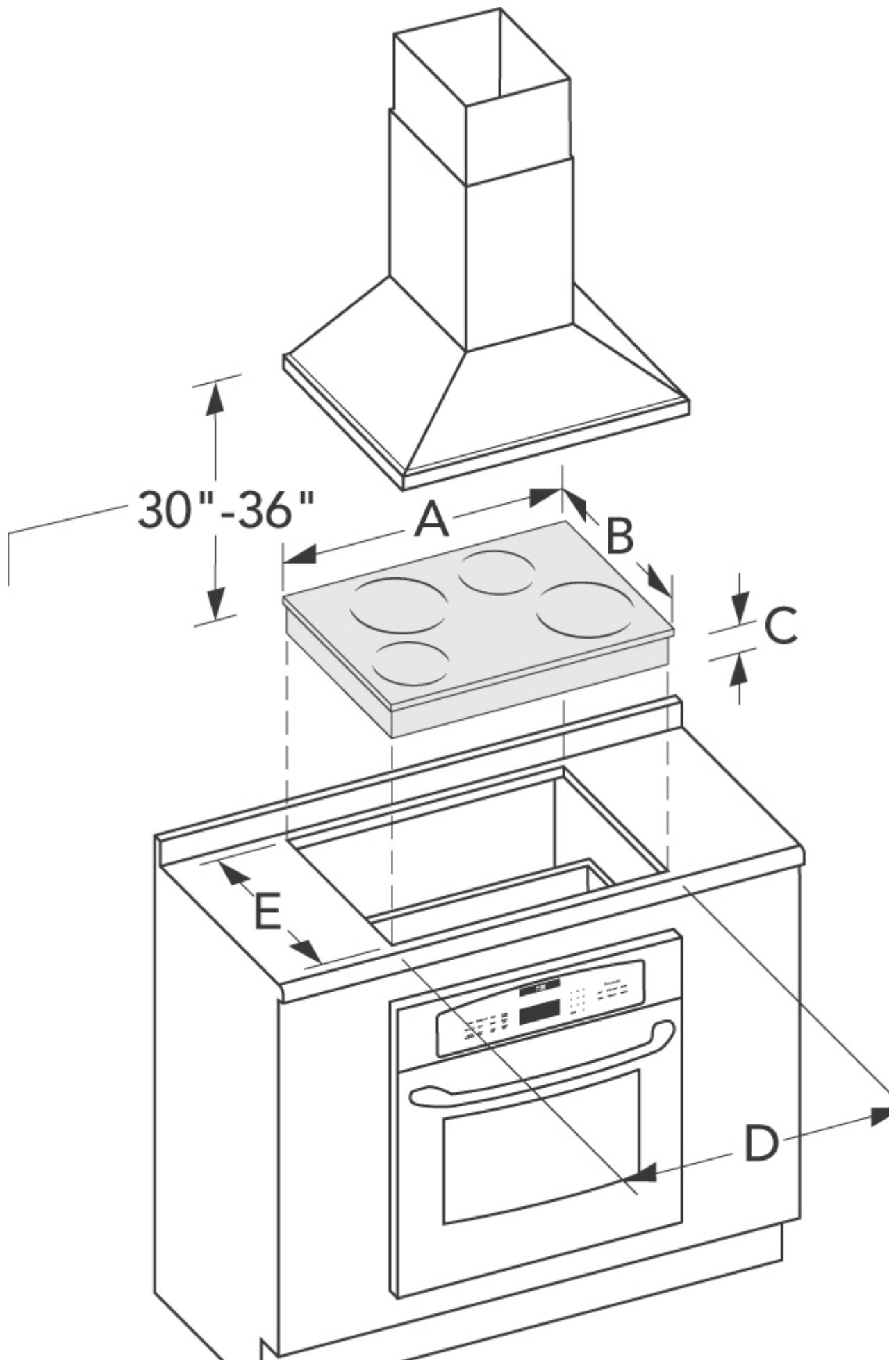

[Click Here to View Features](#)

