

# SIDE-BY-SIDE REFRIGERATOR/FREEZER WITH DISPENSER FULL OVERLAY MODEL – DIMENSIONS 48" WIDTH (CONTINUED)

Overhead

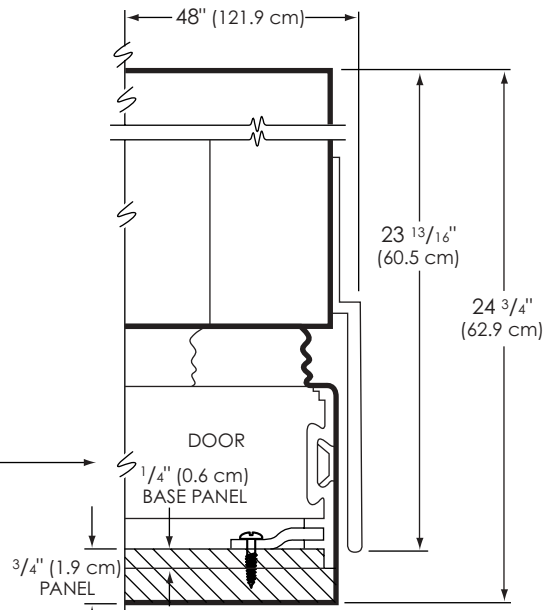

Front

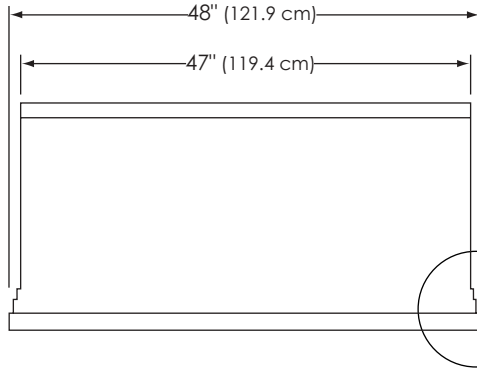
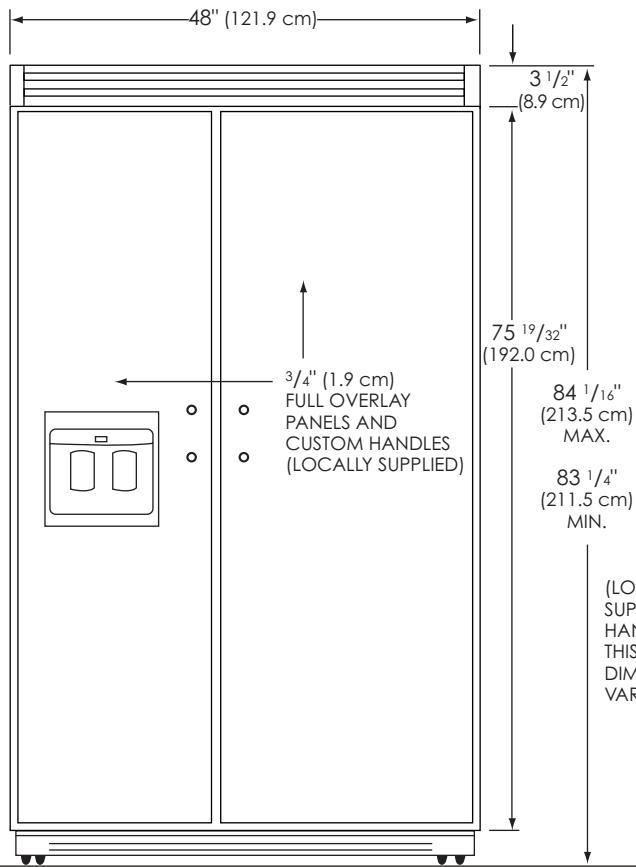

Side

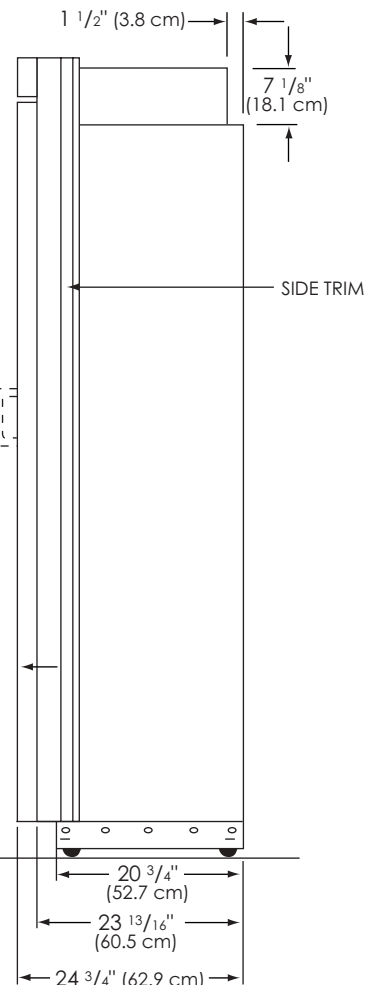

# SIDE-BY-SIDE REFRIGERATOR/FREEZER WITH DISPENSER FULL OVERLAY MODEL – DIMENSIONS 48" WIDTH (CONTINUED)

## Cutout

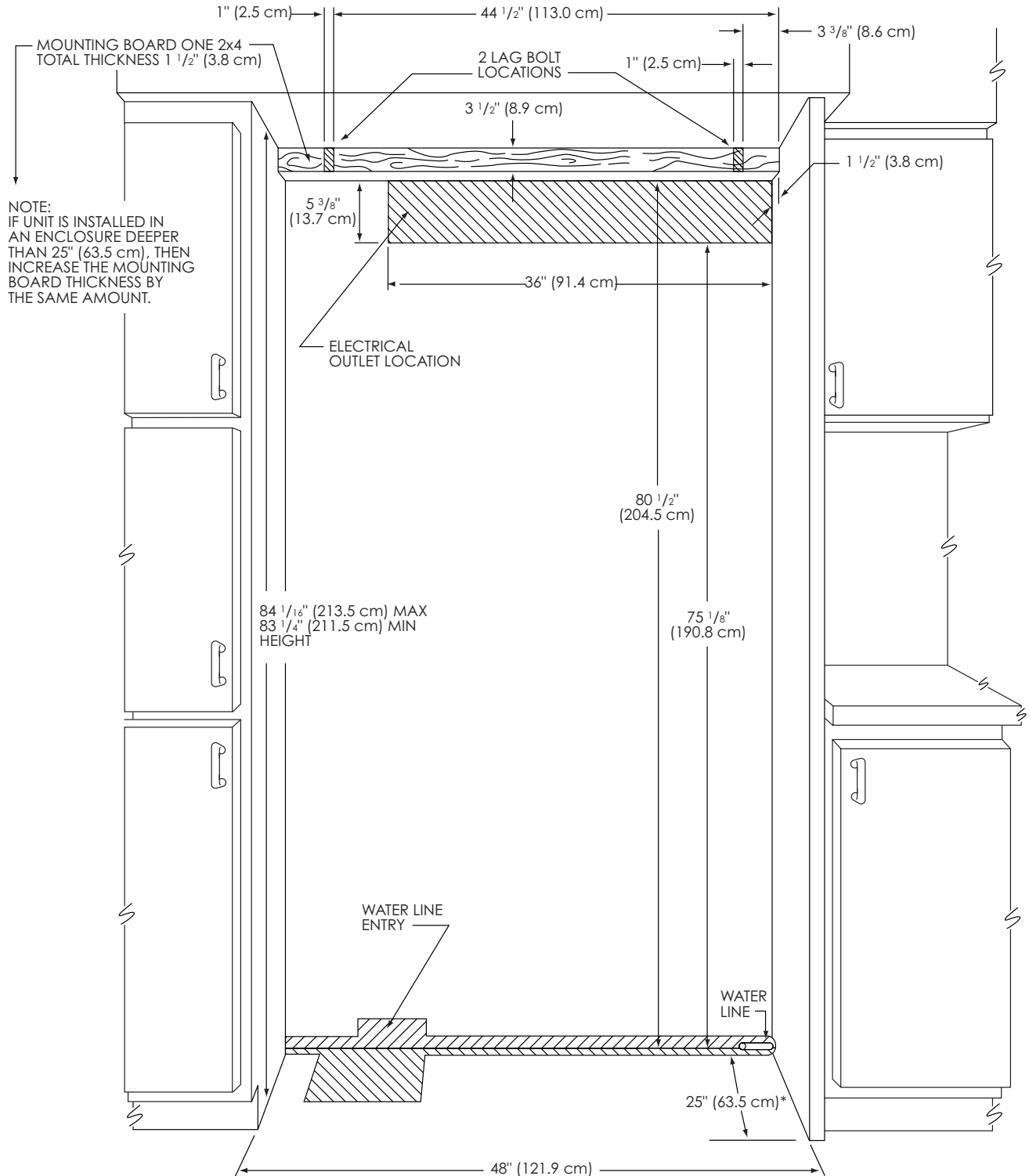

\* Full Overlay models fit flush in 25" deep cabinet openings. They can be installed in standard 24" deep openings. The door faces and top ventilation grill will protrude 3/4" into the room, ideal for alignment with full overlay cabinet doors.

# SIDE-BY-SIDE REFRIGERATOR/FREEZER WITH DISPENSER FULL OVERLAY MODEL – DIMENSIONS 48" WIDTH (CONTINUED)

Custom  
Panel

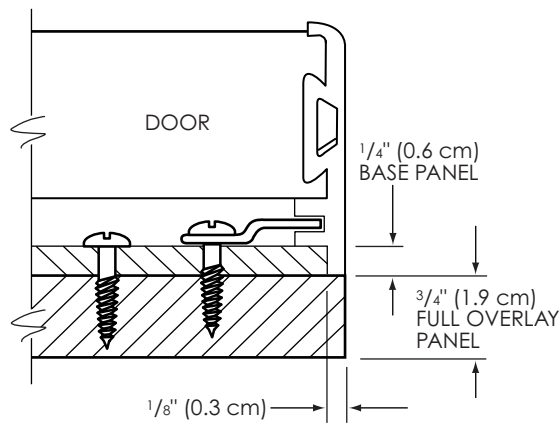
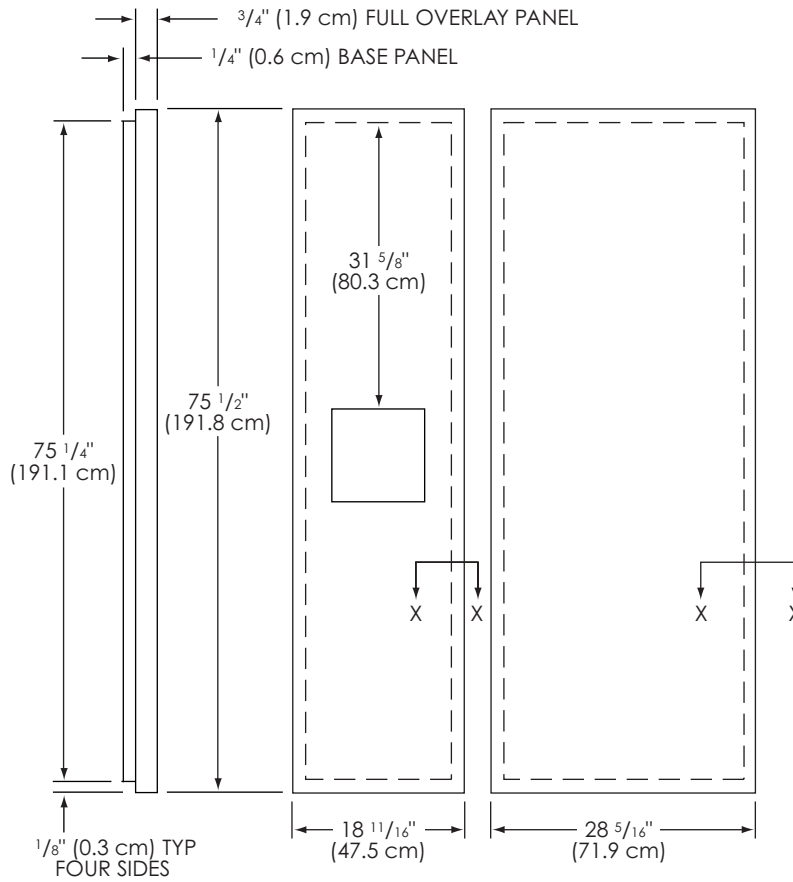

# SIDE-BY-SIDE REFRIGERATOR/FREEZER WITH DISPENSER FULL OVERLAY MODEL – DIMENSIONS 48" WIDTH (CONTINUED)

## Dispenser Cutout

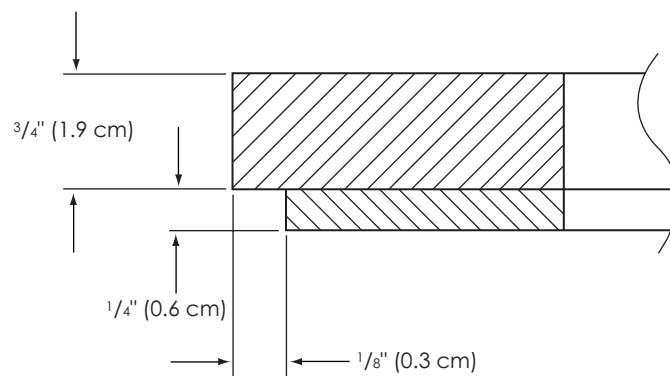
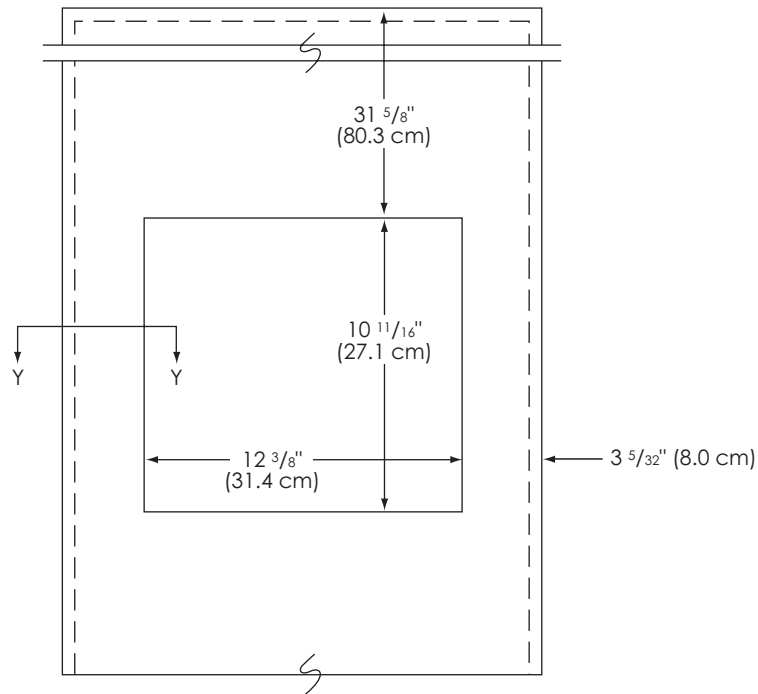

SECTION Y-Y

## BASIC SPECIFICATIONS

DESCRIPTION	DFSB483D Designer
<b>Overall Width</b>	48" (121.9 cm)
<b>Overall Height from Bottom</b>	Minimum 83 1/4" (211.5 cm) Maximum 84 1/16" (213.5 cm)
<b>Overall Depth from Rear</b>	To front edge of side trim – 23 13/16" (60.5 cm) To front edge of top grille – 24 3/4" (62.9 cm) To edge of handle – 24" (61.0 cm)
<b>Cutout Width</b>	48" (121.9 cm)
<b>Cutout Height</b>	Minimum 83 1/4" (211.5 cm) Maximum 84 1/6" (213.5 cm)
<b>Cutout Depth</b>	25" (63.5 cm); can be installed in 24" (61.0 cm) openings – door faces and grille will protrude 3/4" (1.9 cm) into room
<b>Electrical Requirements</b>	115VAC/60Hz, 15 amp circuit, 3-wire cord with grounded 3-prong plug attached to product
<b>Maximum Amp Usage</b>	11.5 amps
<b>Inlet Water Requirements</b>	1/4" copper tubing inlet waterline – Minimum 20 psi; Maximum 120 psi
<b>Overall Interior Capacity</b>	Refrigerator – 17.9 cu. ft. (506.9 L) Freezer – 8.5 cu. ft. (240.7 L) Total capacity – 26.4 cu. ft. (747.6 L)
<b>Approximate Shipping Weight</b>	650 lb. (292.5 kg)