

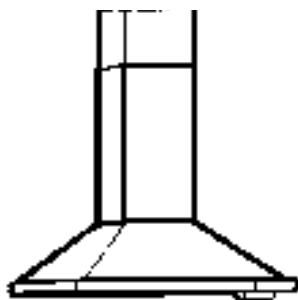

ISOLA

Island Mount Canopy Rangehood

- Installation Instructions
- Use and Care Information



READ AND SAVE THESE INSTRUCTIONS

The Installer must leave these instructions with the homeowner. The homeowner must keep these instructions for future reference and for local electrical inspectors' use.

READ THESE INSTRUCTIONS BEFORE YOU START INSTALLING THIS RANGEHOOD

WARNING: - TO REDUCE THE RISK OF A RANGE TOP GREASE FIRE: *Never leave surface units unattended at high settings. Boilovers cause smoking and greasy spillovers that may ignite. Heat oils slowly on low or medium setting. Always turn hood ON when cooking at high heat or when cooking flaming foods. Clean ventilating fans frequently. Grease should not be allowed to accumulate on fan or filter. Use proper pan size. Always use cookware appropriate for the size of the surface element.*

WARNING: - TO REDUCE THE RISK OF INJURY TO PERSONS IN THE EVENT OF A RANGE TOP GREASE FIRE, OBSERVE THE FOLLOWING: SMOTHER FLAMES with a close-fitting lid, cookie sheet, or metal tray, then turn off the burner. **BE CAREFUL TO PREVENT BURNS.** *If the flames do not go out immediately EVACUATE AND CALL THE FIRE DEPARTMENT. NEVER PICK UP A FLAMING PAN - You may be burned. DO NOT USE WATER, including wet dishcloths or towels - a violent steam explosion will result. Use an extinguisher ONLY if: 1. You know you have a Class ABC extinguisher, and you already know how to operate it. 2. The fire is small and contained in the area where it started. 3. The fire department is being called. 4. You can fight the fire with your back to an exit.*

ALL WALL AND FLOOR OPENINGS WHERE THE RANGEHOOD IS INSTALLED MUST BE SEALED.

This rangehood requires at least 24" of clearance between the bottom of the rangehood and the cooking surface or countertop. This minimum clearance may be higher depending on local building code. For example, for gas ranges, a minimum of 30" may be required. The maximum depth of overhead cabinets is 13". Overhead cabinets on both sides of this unit must be a minimum of 18" above the cooking surface or countertop. Consult the cooktop or range installation instructions given by the manufacturer before making any cutouts. **MOBILE HOME INSTALLATION** The installation of this rangehood must conform to the Manufactured Home Construction and Safety Standards, Title 24 CFR, Part 3280 (formerly Federal Standard for Mobile Home Construction and Safety, Title 24, HUD, Part 280). Four wire power supply must be used and the appliance wiring must be revised. See Electrical Requirements.

LISEZ BIEN CETTE FICHE AVANT D'INSTALLER LA HOTTE

AVERTISSEMENT - POUR MINIMISER LE RISQUE D'UN FEU DE GRAISSE SUR LA TABLE DE CUISSON : *Ne jamais laisser un élément de la table de cuisson fonctionner sans surveillance à la puissance de chauffage maximale; un renversement/débordement de matière grasseuse pourrait provoquer une inflammation et le génération de fumée. Utiliser toujours une puissance de chauffage moyenne ou basse pour le chauffage d'huile. Veiller à toujours faire fonctionner le ventilateur de la hotte lors d'une cuis-son avec une puissance de chauffage élevée ou lors de la cuisson d'un mets à flamber. Nettoyer fréquemment les ventila-teurs d'extraction. Veiller à ne pas laisser de la graisse s'accumuler sur les surfaces du ventilateur ou des fil-tres. Utiliser toujours un ustensile de taille appropriée. Utiliser toujours un ustensile de taille adapté à la taille de l'élé-ment chauffant.*

AVERTISSEMENT: - POUR PRÉVENIR LES BLESSURES EN CAS DE FEU SUIVRE LES RECOMMANDATIONS SUIVANTES: **ÉTOUFFEZ LE FEU** avec un couvercle métallique et fermez le brûleur. **Si le feu ne s'éteint pas tout de suite, QUITTEZ LES LIEUX ET APPELEZ LES POMPIERS. NE TOUCHEZ JAMAIS UNE CASSEROLE EN FLAMMES. N'UTILISEZ JAMAIS DE L'EAU** ou un torchon mouillé pour éteindre le feu - ce qui pourrait causer une explosion de vapeur. **N'utilisez un extincteur que si: 1. Vous avez un modèle ABC et vous connaissez bien son mode d'emploi. 2. Le feu est petit et peu répandu. 3. Les pompiers sont déjà prévenus. 4. Vous avez une sortie derrière vous.**

TOUTE OUVERTURE DANS LE MUR OU LE PLANCHER À PROXIMITÉ DE LA HOTTE DOIT ÊTRE SCÉLLÉ

Gardez 24 po. de hauteur entre le bas de la hotte et la surface de cuisson. Cette hauteur minimum peut être plus haute suivant le code municipal. Par exemple, les cuisinières à gaz peuvent requérir 30 po. de hauteur. Les armoires au-dessus ne dépasseront pas 13 po. de profondeur. Les armoires au-dessus de chaque côté devront être au moins à 18 po. au-dessus de la surface de cuisson. Consultez la fiche technique avant de découper les armoires. L'installation de cette hotte doit être conforme aux Réglements de Manufactured Home Construction and Safety Standards, titre 24 CFR, Section 3280 (anciennement Federal Standard for Mobile Home Construction and Safety Standards, titre 24 CFR, Section 3280 (anciennement Federal Standard for Mobile Home Construction and Safety, titre 24, HUD, Section 280). Le branchement électrique se fait avec une raccordement à 4 fils. Consultez la fiche technique électrique.

VENTING REQUIREMENTS

Determine which venting method is best for your application. Ductwork can extend either through the wall or the roof.

The length of the ductwork and the number of elbows should be kept to a minimum to provide efficient performance. The size of the ductwork should be uniform. Do not install two elbows together. Use duct tape to seal all joints in the ductwork system. Use caulking to seal exterior wall or floor opening around the cap.

Flexible ductwork is not recommended. Flexible ductwork creates back pressure and air turbulence that greatly reduces performance.

Make sure there is proper clearance within the wall or floor for exhaust duct before making cutouts. Do not cut a joist or stud unless absolutely necessary. If a joist or stud must be cut, then a supporting frame must be constructed. For best results, remote blowers should transition to 9" round duct as soon as possible. If small ducting is used, it should be transition to 9" round as soon as possible.

FOR MORE SPECIFIC DUCTWORK INFORMATION, GO TO PAGE 4.

WARNING - To Reduce The Risk Of Fire, Use Only Metal Ductwork.

WARNING

- Venting system **MUST** terminate outside the home.
- **DO NOT** terminate the ductwork in an attic or other enclosed space.
- **DO NOT** use 4" laundry-type wall caps.
- Flexible-type ductwork is not recommended.
- **DO NOT** obstruct the flow of combustion and ventilation air.
- Failure to follow venting requirements may result in a fire.

ELECTRICAL REQUIREMENTS

A 120 volt, 60 Hz AC-only electrical supply is required on a separate 15 amp fused circuit. A time-delay fuse or circuit breaker is recommended. The fuse must be sized per local codes in accordance with the electrical rating of this unit as specified on the serial/rating plate located inside the unit near the field wiring compartment. **THIS UNIT MUST BE CONNECTED WITH COPPER WIRE ONLY.** Wire sizes must conform to the requirements of the National Electrical Code, ANSI/NFPA 70 - latest edition, and all local codes and ordinances. Wire size and connections must conform with the rating of the appliance. Copies of the standard listed above may be obtained from:

National Fire Protection Association
Batterymarch Park
Quincy, Massachusetts 02269

This appliance should be connected directly to the fused disconnect (or circuit breaker) through flexible, armored or nonmetallic sheathed copper cable. Allow some slack in the cable so the appliance can be moved if servicing is ever necessary. A UL Listed, 1/2" conduit connector must be provided at each end of the power supply cable (at the appliance and at the junction box).

When making the electrical connection, cut a 1 1/4" hole in the wall. A hole cut through wood must be sanded until smooth. A hole through metal must have a grommet.

SUITABLE FOR USE WITH SOLID STATE SPEED CONTROLS.

WARNING - TO REDUCE THE RISK OF FIRE, ELECTRICAL SHOCK, OR INJURY TO PERSONS, OBSERVE THE FOLLOWING: Use this unit only in the manner intended by the manufacturer. If you have any questions, contact the manufacturer.

Before servicing or cleaning unit, switch power off at service panel and lock the service disconnecting means to prevent power from being switched on accidentally. When the service disconnecting means cannot be locked, securely fasten a prominent warning device, such as a tag, to the service panel.

CAUTION: For General Ventilating Use Only. Do Not Use To Exhaust Hazardous or Explosive Materials and Vapors.

WARNING - TO REDUCE THE RISK OF FIRE, ELECTRICAL SHOCK, OR INJURY TO PERSONS, OBSERVE THE FOLLOWING: Installation Work And Electrical Wiring Must Be Done By Qualified Person(s) In Accordance With All Applicable Codes And Standards, Including Fire-Rated Construction.

Sufficient air is needed for proper combustion and exhausting of gases through the flue (chimney) of fuel burning equipment to prevent backdrafting. Follow the heating equipment manufacturer's guideline and safety standards such as those published by the National Fire Protection Association (NFPA), and the American Society for Heating, Refrigeration and Air Conditioning Engineers (ASHRAE), and the local code authorities.

When cutting or drilling into wall or ceiling, do not damage electrical wiring and other hidden utilities.

Ducted fans must always be vented to the outdoors.

WARNING

- Electrical ground is required on this rangehood.
- If cold water pipe is interrupted by plastic, nonmetallic gaskets or other materials, **DO NOT** use for grounding.
- **DO NOT** ground to a gas pipe.
- **DO NOT** have a fuse in the neutral or grounding circuit. A fuse in the neutral or grounding circuit could result in electrical shock.
- Check with a qualified electrician if you are in doubt as to whether the rangehood is properly grounded.
- Failure to follow electrical requirements may result in a fire.

RÈGLEMENTS D'ÉVACUATION

Confirmer la sortie d'évacuation - soit par le mur, soit par le toit.

Utilisez une longueur de tuyauterie minimale avec les moindres de coudes pour la plus grande efficacité. Le diamètre de tuyauterie doit être uniforme. N'installez jamais 2 coudes ensemble. Scellez bien tous les joints avec un ruban adhésif métallique à l'intérieur et scellez bien le clapet extérieur avec du calfeutrage.

Utilisez un tuyau d'évacuation rigide lorsque possible. Un tuyau flexible égale deux fois plus qu'un tuyau rigide, ce qui réduit la puissance d'évacuation. Un conduit d'évacuation flexible crée une contre-pression et une turbulence de l'air qui réduisent considérablement la performance.

Veillez à ce que l'espace pour le tuyau soit ample - ainsi on n'aurait pas besoin de découper les supports de mur intérieur. Si ce découpage est nécessaire, veillez bien à ce qu'un renforcement soit mis en place.

Pour de meilleurs résultats, utilisez un tuyau de transition de 9 pouces dès que possible.

RÈGLEMENTS D'ÉVACUATION ADDITIONNEL -
PAGE 8

AVERTISSEMENT - Pour Ne Pas Risquer Un Feu, Utilisez Seulement Les Matériaux Métalliques.



AVERTISSEMENT

- Le système d'évacuation DOIT sortir à l'extérieur.
- N'ÉVACUEZ PAS le conduit soit dans une mansarde soit dans un espace enfermé.
- N'UTILISEZ PAS un clapet de séchoir à 4 pouces.
- N'utilisez pas un conduit flexible.
- N'ENCOMBREZ PAS la circulation d'air.
- Faute de suivre cet avertissement pourrait occasionner un feu.

FICHE TECHNIQUE ÉLECTRIQUE

Le raccordement électrique doit se faire avec un circuit séparé de 15 ampères fusible à 120V, 60 Hz, courant alternatif. On recommande un coupe-circuit. La taille du fusible doit se conformer aux codes municipaux suivant la spécification électrique sur la plaque intérieure. Le diamètre du fil devra aussi se conformer aux règlements du code national électrique, ANSI/NFPA 70 - ainsi qu'aux règlements locaux et les spécifications de cet appareil. On peut obtenir ces informations chez:

l'Association Nationale de la Prévention du Feu
Batterymarch Park
Quincy, Massachusetts 02269

Raccordez cet appareil directement au coupe-circuit avec un fil flexible couvert en cuivre en laissant un peu de lâchement dans le fil pour permettre le déplacement de l'appareil. Veillez à ce qu'un contact d'un demi-pouce (1/2 po.) soit installé à chaque bout de fil (soit à l'appareil ainsi qu'à la boîte à fusible).

Faites un trou de 1 1/4 po. dans le mur. S'il s'agit d'un trou en bois - sablez-le bien, tandis qu'un trou passant par le métal demande un bouche-trou.

A utiliser avec un dispositif de réglage de vitesse à semi-conducteurs.

AVERTISSEMENT – POUR MINIMISER LES RISQUES D'INCENDIE, CHOC ÉLECTRIQUE OU DOMMAGES CORPORELS, OBSERVER LES PRESCRIPTIONS SUIVANTES: Suivez les recommandations du fabricant et entre en communication avec lui pour toute information.

Fermez le courant avant tout entretien et veillez à ce qu'il reste fermé. Si on ne peut pas verrouiller le panneau du service électrique, affichez un avis de danger sur la porte.

AVIS: Pour L'évacuation Générale - Veillez à Ne Pas Evacuer Des Matériaux Ou Vapeurs Explosif.

AVERTISSEMENT – POUR MINIMISER LES RISQUES D'INCENDIE, CHOC ÉLECTRIQUE OU DOMMAGES CORPORELS, OBSERVER LES PRESCRIPTIONS SUIVANTES: L'installation Et Le Raccordement Electrique Doivent Se Faire Par Un Technicien Qualifié Selon Tous Les Codes Municipaux.

Afin d'obtenir un rendement maximal en ce qui a trait à la combustion ainsi qu'à l'évacuation des gaz par la conduite de cheminée, une bonne aération est nécessaire pour tous les appareils à combustion. Suivez les conseils et mesures de sécurité du fournisseur tels que ceux publiés par l'Association Nationale de la Sauvegarde contre l'Incendie et l'Association Américaine d'Ingénieurs de Chauffage, Frigorifaction et Air Climatisé ainsi que les codes municipaux.

En perçant un mur veillez à ne pas perforer un autre fil électrique.

Une hotte à évacuation extérieure doit être raccordée à l'extérieur.



AVERTISSEMENT

- Une prise à terre est nécessaire pour cette hotte.
- N'utilisez pas un tuyau à l'eau froide pour la mise à terre s'il est branché à un joint plastique, non-métallique ou autre.
- NE JOIGNEZ PAS la mise à terre à conduit de gaz.
- N'INSTALLEZ PAS un fusible dans le circuit de mise à terre - ce qui peut causer une secousse électrique.
- Vérifiez avec un électricien certifié à ce que la hotte soit bien mise à terre.
- Faute de suivre ces recommandations pourrait occasionner un feu.

TOOLS NEEDED FOR INSTALLATION

- Saber Saw or Jig Saw
- Drill
- 1 1/4" Wood Drill Bit
- Pliers
- Phillips Screwdriver
- Flat Blade Screwdriver
- Wire Stripper or Utility Knife
- Metal Snips
- Measuring Tape or Ruler
- Level
- Pencil
- Caulking Gun
- Duct Tape
- Crescent Wrench
- Allen Wrench Set

PARTS SUPPLIED FOR INSTALLATION

- 1 Hardware Package
- 1 Literature Package

PARTS NEEDED FOR INSTALLATION

- 2 Conduit Connectors
- Power Supply Cable
- Wiring Cable - Optional Remote Blower Only
- 1 Wall or Roof Cap
- All Metal Ductwork

OPTIONAL ACCESSORIES AVAILABLE

• Utensil Bar

Stainless steel bar for hanging utensils under sides of the canopy
part # 6099924

• Ductless Conversion Kit

For non-vented installations only
part # 6097115 - Stainless
part # 6097116 - White
part # 6097117 - Black

• Replacement Charcoal Filters (2 in kit)

For non-vented installations only,
replace charcoal filters as needed
part # 6093034

PLAN THE INSTALLATION

The standard installation for this rangehood is ducted to the outside of the house. This rangehood can also be installed as ductless which requires a **Ductless Conversion Kit** from the dealer. If desired, this rangehood can use an optional remote blower. If the remote blower is used, the internal blower must be removed and discarded. Both blowers cannot be used together. The remote blower connects using a separate wiring cable not supplied with the unit and should be installed at the same time as the ductwork.

The Isola chimney is adjustable and designed to meet varying ceiling heights as indicated in **FIGURE 1**. The chimney can be adjusted for ceilings between 7' 10 7/8" and 9' 3" depending on the distance between the bottom of the hood and the cooktop (**distance x in FIGURE 1**). For shorter ceilings, the entire chimney support (**T in FIGURE 2**) must be recessed up into the ceiling. For higher ceilings, build a solid structure down and attach the chimney support to this structure.

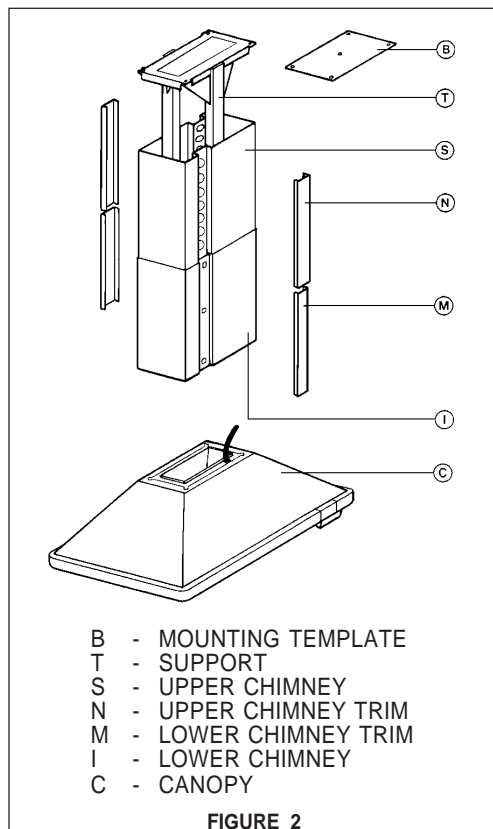
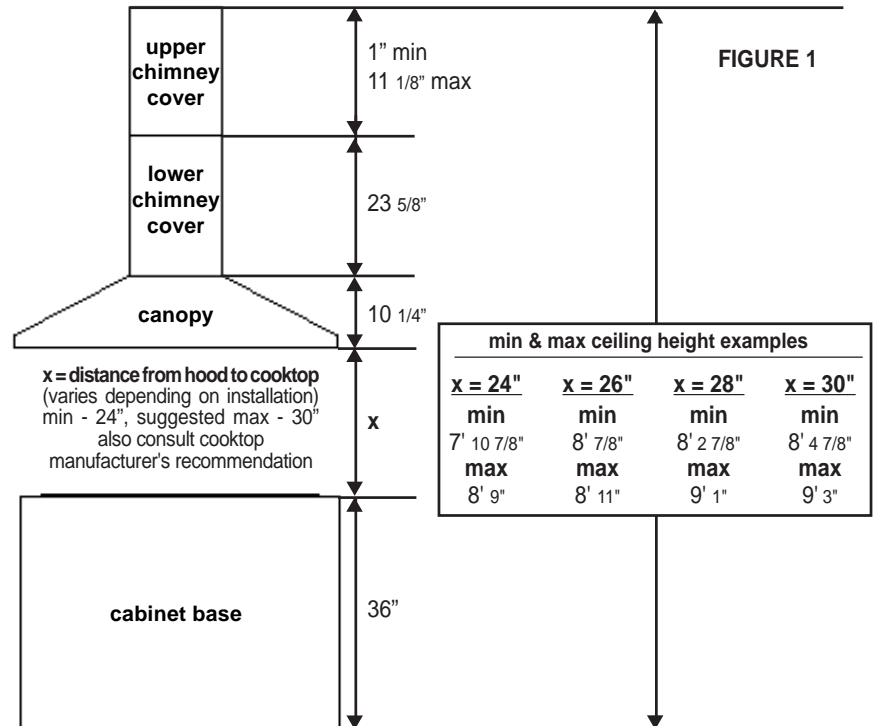

ATTACHING THE CHIMNEY

The rangehood attaches to the ceiling by a support inside the chimney (**T**) as illustrated in **FIGURE 2**. This support must be attached to the ceiling before the canopy is attached to this support. Since this structure supports the weight of the canopy, it must be firmly attached to the ceiling. **FOR CONCRETE CEILINGS** - Use inserts and screws provided. **FOR WOOD CEILINGS** - Use four 4" long wood screws. **FOR PLASTER OR SHEET ROCK CEILINGS** - If possible, the support must be attached to the ceiling joists. If not, a supporting structure behind the sheet rock must be built.

CALCULATE THE DUCTRUN LENGTH

The ductrun should not exceed 35 equivalent feet if ducted with the required minimum of 3 1/4" by 10" rectangular duct and 55 equivalent feet if ducted with 9" round ductwork (Remote blowers require 9" round duct). Calculate the length of the ductwork by adding the equivalent feet in **FIGURE 3** for each piece of duct in the system. An example is given in **FIGURE 4**.

45° Elbow	3.0 feet
90° Elbow	5.0 feet
90° Flat Elbow	12.0 feet
Wall Cap	0.0 feet

FIGURE 3

9 Feet Straight Duct	9.0 feet
2 - 90° Elbows	10.0 feet
Wall Cap	0.0 feet
Total System	19.0 feet

FIGURE 4

For best results, use no more than three 90° elbows. Make sure that there is a minimum of 24" of straight duct between elbows if more than one is used. Do not install two elbows together. If you must elbow right away, do it as far away from the hood's exhaust opening as possible.

⚠ WARNING

DUE TO THE SIZE AND WEIGHT OF THIS RANGEHOOD, THE SUPPORT MUST BE FIRMLY ATTACHED TO THE CEILING. For plaster or sheet rock ceilings, the support must be attached to the joists. If this is not possible, a support structure must be built behind the plaster or sheet rock. The manufacturer assumes no responsibility for injury or damage caused by improper installations.

ATTACH THE SUPPORT

1. Put a thick, protective covering over cooktop, set-in range or countertop to protect from damage or dirt.
2. Determine and clearly mark with a pencil the center on the ceiling where the rangehood will be installed.

3. A template for mounting the support is supplied in the carton with the support. Use this template to mark holes for support on the ceiling. The chimney must be disassembled as indicated in **FIGURE 5** to reveal the support. Before disassembling the chimney, remove all screws (3).

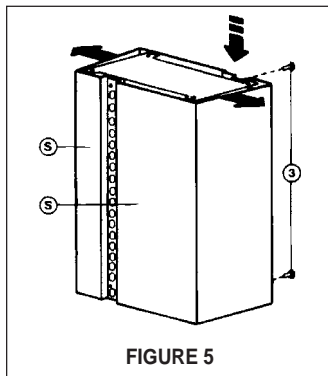

4. Determine and make all necessary cuts for the ductwork. Install damper when connecting ductwork. Install ductwork before mounting the support. The damper attaches to the inside bottom of the chimney support structure. It is necessary to attach your ductwork to this damper and run the ductwork inside the chimney support structure.

5. Determine the proper location for the Power Supply Cable as indicated on the template. Use a 1 1/4" Drill Bit to make this hole. Run the Power Supply Cable. Use caulking to seal around the hole. **DO NOT turn on the power until installation is complete!** Two knockouts are provided near the exhaust exit on the canopy. One is for the Power Supply Cable and one for an optional remote blower. Make sure that you use the correct knockout.

6. Attach the support to the ceiling. Make sure that the support is firmly connected to the ceiling. The height of the canopy can be adjusted by changing the length of the support.

Adjust the support length by loosening the four set screws (**V** in **FIGURE 6**). The bottom of the canopy will be approximately 10 1/4 inches below the bottom of the support. Make sure that all four set screws are firmly tightened before attaching the canopy. To prevent damage, the support must be adjusted **BEFORE** attaching the canopy.

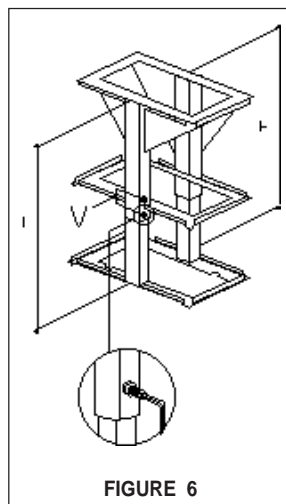

INSTALL THE RANGEHOOD

1. Remove the unit from the carton and place on a flat surface for assembly. Cover the surface to prevent accidental damage. Remove all parts including the mounting hardware before discarding the carton.

2. Remove the grease filters and set aside. The grease filters are removed by pressing the handle in front of the filter as indicated in **FIGURE 7**. When replacing, make sure the filters are properly positioned with the handles visible in front.

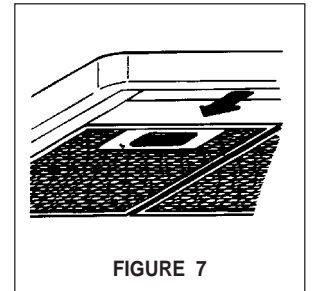

3. Remove the cover from the field wiring compartment. Remove the wiring electrical knockout using a flat-blade screwdriver.

4. The canopy attaches to the support by four bolts located next to the duct exhaust opening. Loosen the four bolts so that there is approximately 1/4" space between the bolt head and the canopy. **FIGURE 8** shows how the canopy attaches to the support.

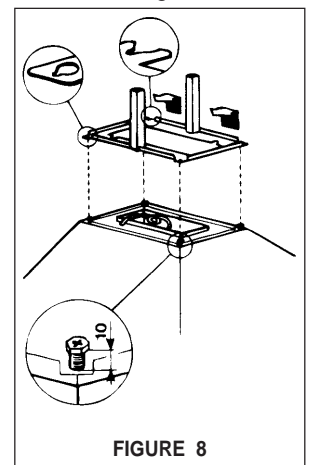

5. Lift the canopy and insert the bolts into the slots on the support. Tighten the four bolts. Due to the weight of the rangehood, two people should lift it to avoid injuries. Make sure that the bolts are properly seated in the slots and fully tightened.

6. Connect the Power Supply Cable to the rangehood. Attach the White lead of the power supply to the White lead of the rangehood with a twist-on type wire connector. Attach the Black lead of the power supply to the Black lead of the rangehood with a twist-on type wire connector. Connect the Green (Green and Yellow) ground wire under the Green grounding screw.

If your installation uses an optional remote blower, connect the wiring cable for the blower. **DO NOT CONNECT THE REMOTE BLOWER DIRECTLY TO THE POWER SUPPLY CABLE IN THE FIELD WIRING COMPARTMENT.**

7. Replace the wiring compartment cover and grease filters.

For ductless installations:

Ductless installations require a **Ductless Conversion Kit**. This kit consists of two lower chimney covers with holes for the exhaust air, a ductless diverter, two grids to cover the holes in the chimney cover, two charcoal filters. The ductless diverter must be installed before the lower chimney covers are attached as in **FIGURE 9**. The chimney covers without holes should be discarded. Once the lower chimney covers with holes are installed, the grids are inserted into the holes as illustrated in **FIGURE 10**.

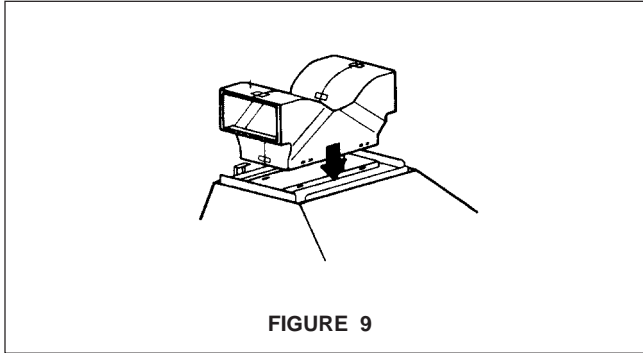

FIGURE 9

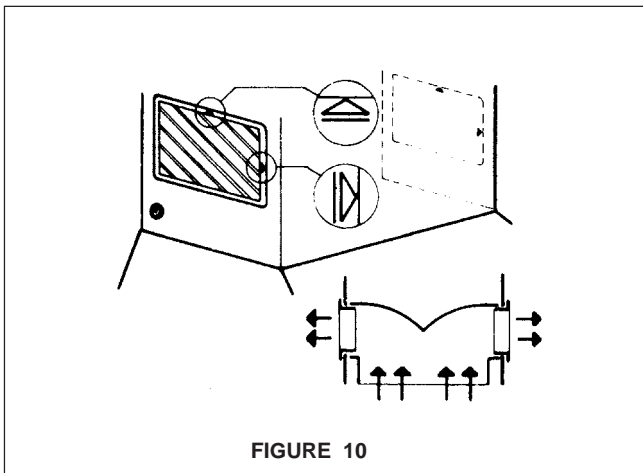

FIGURE 10

8. Attach the chimney cover to the support. The chimney cover is supplied in two sections with each section having two pieces. The upper section of the chimney cover (**S**) must be installed first, then the lower section (**I**). **FIGURES 11 and 12** illustrate the attachment of the chimney cover. The lower section fits over the upper section. Once the covers are in the final position, screws are used to secure the top and bottom of each cover to the support.

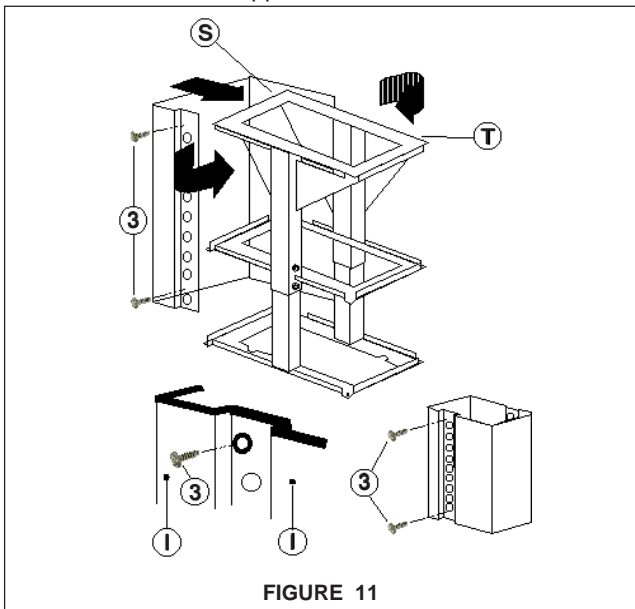

FIGURE 11

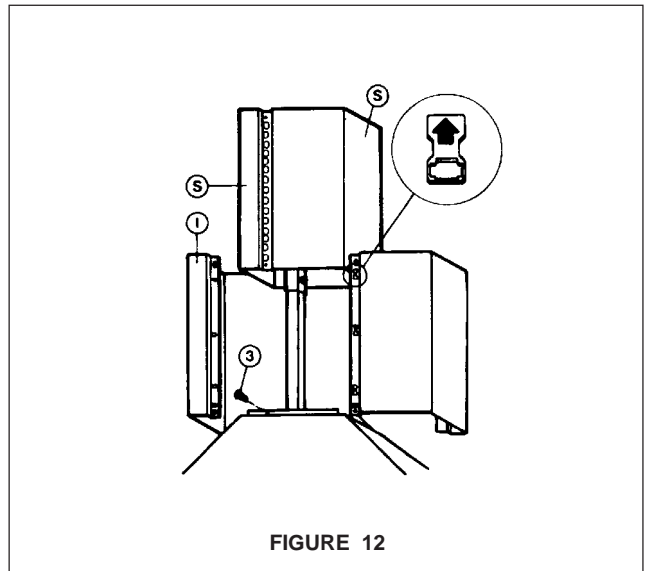

FIGURE 12

9. Trim strips are supplied to cover the seam in the chimney cover. Each strip attaches to the chimney cover as illustrated in **FIGURE 13**. The strips (**M and N**) are held in place by clips (**D**) which fit into the holes (**Y**) in the chimney. It may be necessary to cut the upper trim strips to the proper length before installing. Be careful not to bend the trim strips when cutting.

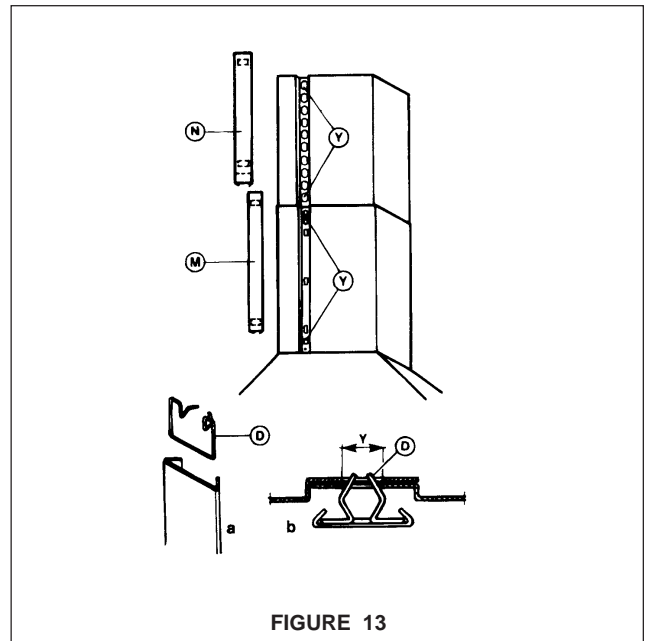

FIGURE 13

10. Turn the power supply on. Turn on blower and light. The rangehood controls are located in a gray panel on the canopy's underside. To open the panel, press up on the front edge and release as indicated in **FIGURE 14**. If the rangehood does not operate, check that the circuit breaker is not tripped or the house fuse blown. If the unit still does not operate, disconnect the power supply and check that the wiring connections have been made properly.

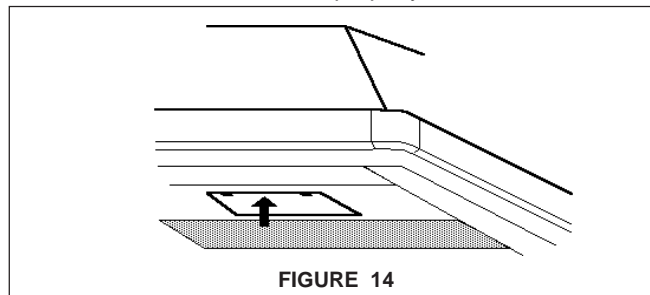
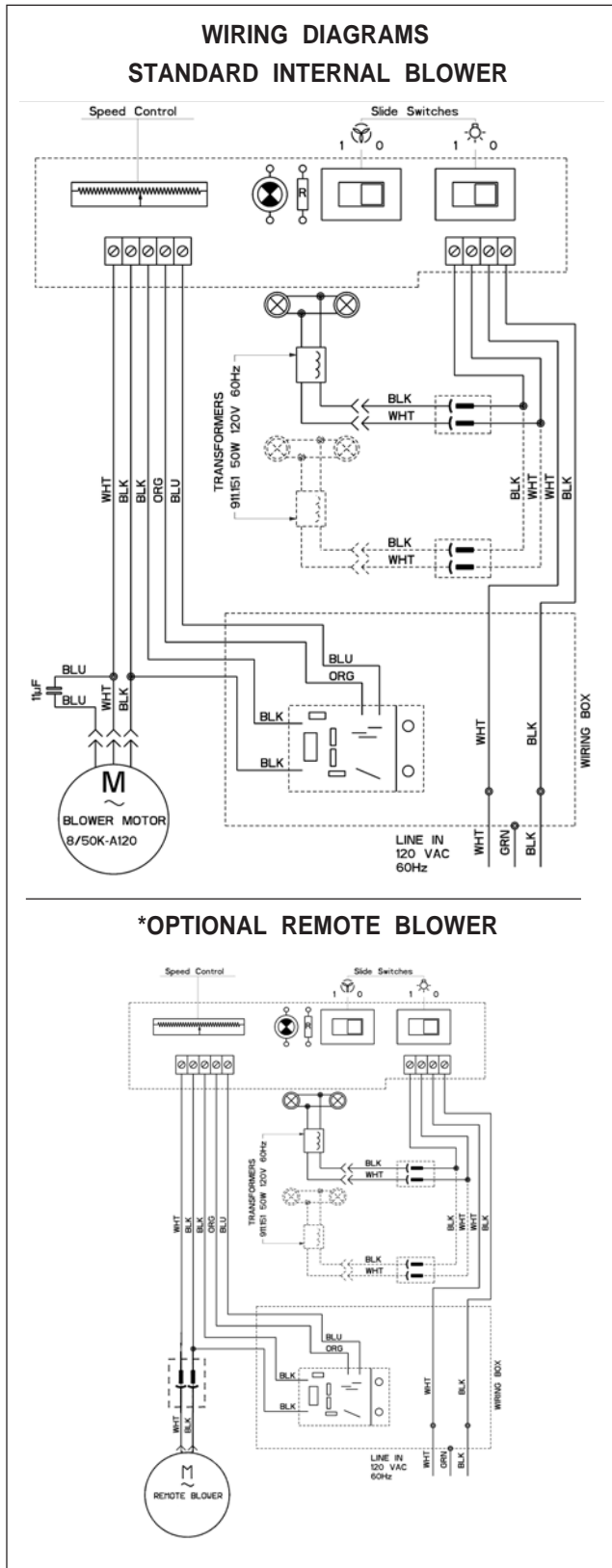

FIGURE 14

WARRANTY & SERVICE

This rangehood carries a limited warranty against manufacturer's defects. To obtain warranty service, contact the dealer from whom you purchased the rangehood, or the local Faber distributor. If you cannot identify a local Faber distributor, contact us at (508) 358-5353 for the name of a distributor in your area.



• This rangehood uses 20 watt halogen lamps.

* If a remote blower is used with this rangehood, current draw must not exceed 4 amps.

USE AND CARE INFORMATION

This rangehood system is designed to remove smoke, cooking vapors and odors from the cooktop area.

Rangehood Control Panel

The control panel, located on the right-hand side under the canopy, is designed to disappear from view when not needed. To open, press upward on the front edge and release. The panel will drop into sight. To close, push upward on the bottom left or right corner of the control panel and it will slide up into the hood. The position and function of each control button are indicated in **FIGURE 15**.

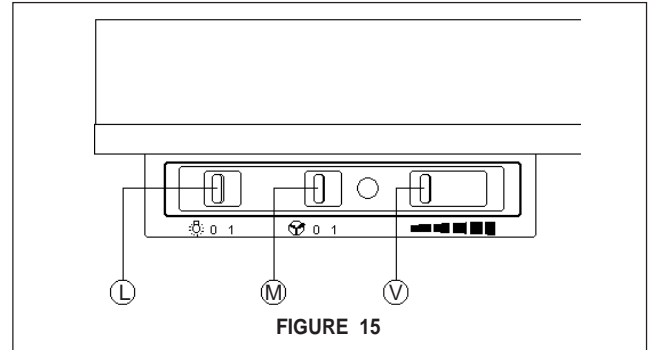

Light On/Off Button (L)

On/Off switch for the halogen lights. Move the switch to "1" to turn the light ON and to "0" to turn it OFF.

Blower On/Off Button (M)

On/Off switch for the blower. Move the switch to "1" to turn the blower ON and to "0" to turn it OFF.

Blower Speed Button (V)

Variable speed control for blower. Move the switch to the far left for LOW Speed and to the far right for HIGH speed.

For Best Results

Start the rangehood several minutes before cooking to develop proper airflow. Allow the unit to operate for several minutes after cooking is complete to clear all smoke and odors from the kitchen.

Cleaning

The metal grease filters should be cleaned frequently in hot detergent solution or washed in the dishwasher. Clean painted hoods with hot soapy water. Stainless steel cleaner should be used on stainless rangehoods. Abrasives and scouring agents can scratch stainless steel finishes and should not be used to clean finished surfaces.

Replacing the Lamps

Before replacing a lamp, turn off the lamp switch to prevent an injury. To replace a halogen lamp (**FIGURE 16**), remove the diffuser clips (**T**) on both ends of the stainless steel lamp panel. Carefully slide the panel all the way to the right. Lower the left end of the panel below the support flange (**Z**), then remove the panel by sliding it back to the left. Remove the lamp by pressing the bulb from the rear. Replace the bulb. Replace the lamp panel by reversing these directions.

