

Features & Benefits



Feature	Benefit
Standard 24" width with two refrigerator drawers	Can be installed into a standard 24"-wide cabinet opening
Touch Control Digital Technology	<ul style="list-style-type: none"> • Full-featured, easy-view command center - right at your fingertips • Easy to set and see the temperatures • Manages key model functions and provides user alerts.
Multiple organizing features:	
- Adjustable "Slide and Divide"	- Can be used in either drawer. Provides the ability to "divide" the drawer for item storage.
- Clear organizing bin in top drawer	- Holds wine, 2-liter bottles and other products. Slides back and forth, allowing easy access to items located beneath the "organizing bin."
- Removable bottom drawer crisper	- Self-contained crisper that is easily removed from either side of the unit.
- Flexible glass crisper shelf	- Items can be stored on top of the shelf, or it can be removed to store taller items.
Stainless steel drawer interiors	<ul style="list-style-type: none"> • Sleek designer appearance • Corrosion resistant
3/4" full overlay drawer panel capability is standard	<ul style="list-style-type: none"> • Provides a fully integrated appearance with surrounding décor • Standard feature on black models • For 1/4" drawer panel one must order replacement drawer handles for EACH drawer (part number 26070-01-5).
Built-in	<ul style="list-style-type: none"> • Provides a custom look • No additional clearance around sides, top or rear for ventilation. Do not obstruct front grille.
Stainless steel	Offers a full wrap stainless steel drawer front, a curved sculpted stainless handle, a stainless-like grille and a black cabinet
Heavy-duty, full extension drawer slides	Allow easy accessibility to contents in the back of drawers
Vinyl-clad cabinet	<ul style="list-style-type: none"> • Black vinyl cabinet on all models provides a rich, textured look • More resistant to scratching, peeling or flaking
Recessed interior lights	Automatically illuminates when the door is opened
Leveling legs	More precise undercounter fit, durable, factory-installed
Sabbath or "Black Out" mode	<ul style="list-style-type: none"> • Easily turn off all lights and control displays • Automatically resets after 36 hours
Contemporary grille design	Integrates seamlessly with surrounding cabinetry

Dimensions & Specifications

Echelon Series

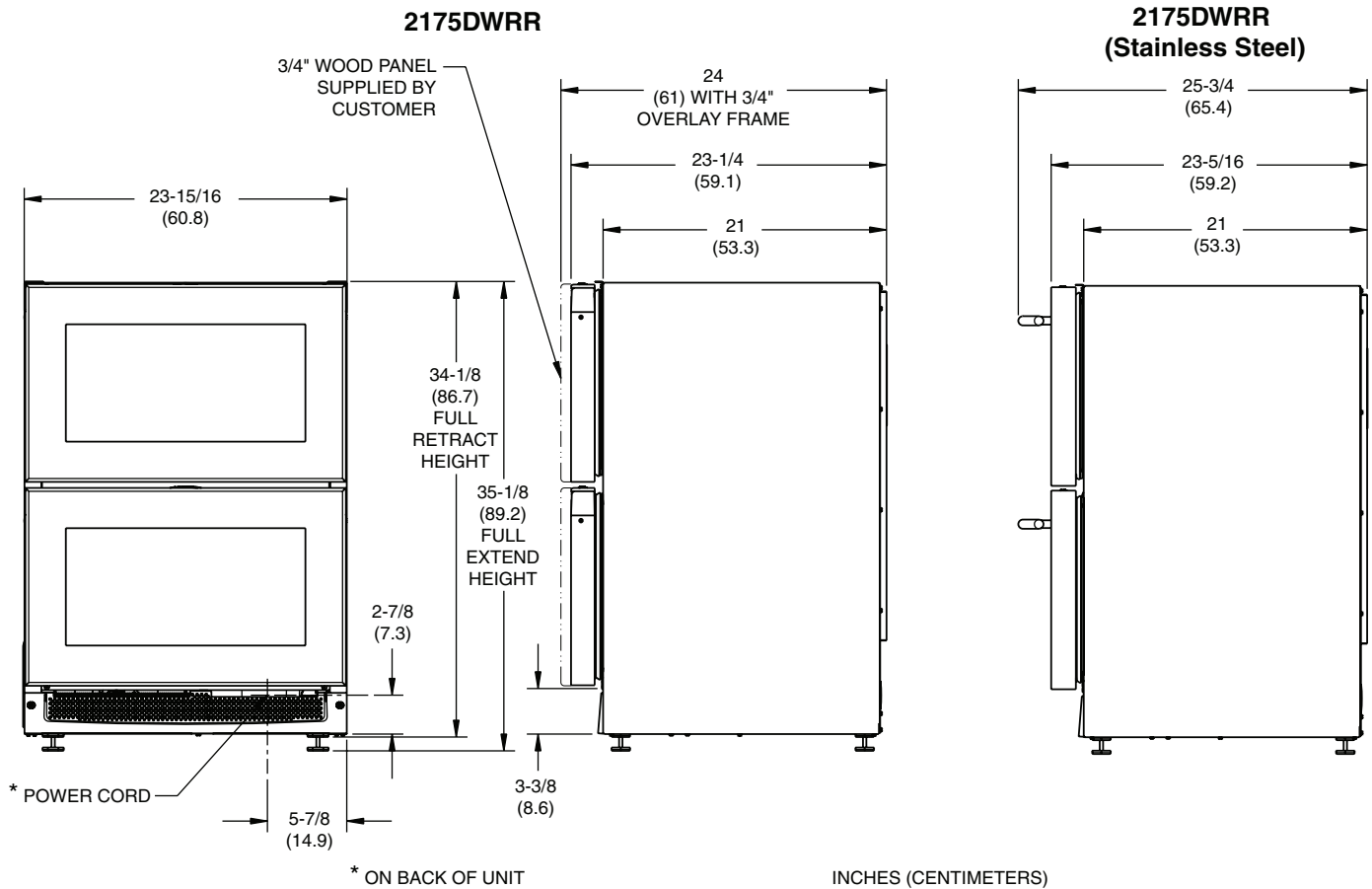

Refrigerator Drawer Model 2175DWRR

Specifications

Shipping Weight:	
Black Models	160 lbs (73 kg)
Stainless Steel Models	163 lbs (74 kg)
(1) Running Amps	2.4
(1) Maximum Start-up Amps	6.5

Capacities

Refrigerator volume	5.5 cubic feet
Freezer volume	N/A
Approximate daily ice production	N/A
Ice storage	N/A

(1) Amps pertain to a 110/115 volt, 60 Hz electrical environment.

Anchoring device included and is required for all installations.

*Please visit www.U-Line.com for Installation Guide.
All specifications subject to change without notice.*



8900 North 55th Street • Milwaukee, Wisconsin 53223
Phone: 414-354-0300 • Fax: 414-354-7905 • www.u-line.com