

POWER TAILGATE LOCK

Instructions

Model PL 8110 for CHEVY SILVERADO/GMC SIERRA, '98 and up

Layout - Rear View:

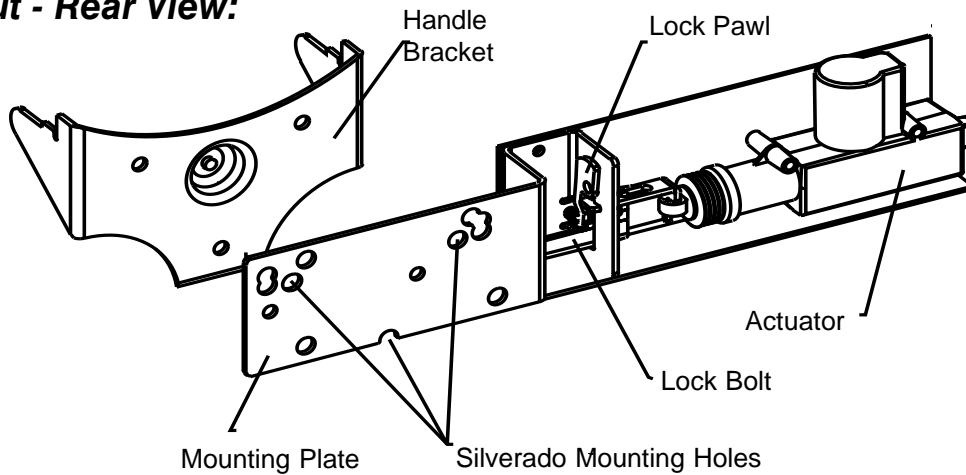

Parts Included:

Power Tailgate Lock Unit
Short Wiring Cable
Long Wiring Cable
Cable Ties
Blue Connector Taps

Tools Required:

13 MM Socket
Pliers

Installation:

1. Remove the black plastic bezel by first loosening the three 13 mm mounting bolts, then lifting the handle and sliding your hand along the inside top edge of the bezel until you feel the two plastic hooks that are 3 inches apart. Bend the tip of the hooks down until they release their hold on the tailgate. Tilt the bezel out at the top and pull it up to release the bottom hooks.
2. Lower the tailgate – FROM THIS POINT UNTIL COMPLETION DO NOT CLOSE THE TAILGATE.
3. Release the rod ends from the scissor links, remove the three screws holding the handle bracket and lift it out of the tailgate.
 4. Test the system by bolting the POWER LOCK to the handle bracket with two screws as shown, connect it to the short and the long wiring harness and take it forward into the cab to test wire it.
 5. **WIRING:** Open the driver's side door and locate the fuse box at the left edge of the dash panel. Open the fuse box panel and locate the **gray wire** and the **tan wire** leading to a light colored relay. Attach the blue connector taps to them and squeeze them shut with the pliers.
 6. Connect the long wiring harness to the blue wire taps and test the system. Lock and unlock the doors using the power door lock switch. The locking mechanism of the power tailgate lock should lock and unlock the handle. The Lock Pawl should drop into the notch of the Lock Bolt to hold it in the locked position. Reverse the wiring if the operation is out of phase. You can now unplug the wires from the blue leads.
7. Place the power tailgate lock inside the tailgate with the actuator on the driver's side.
8. Feed the round bullet connectors on the end of the short wiring cable into a drain hole at the bottom of the tailgate and up the tailgate to the handle opening. Connect them to the wires of the power tailgate lock.
9. Replace the handle in the tailgate. Align the holes of the handle, the power lock, and the tailgate and reinstall the three mounting screws.
10. Connect the rod ends into the scissor links and snap the plastic bezel into place.
11. Route the end of the short cable from the tailgate between the bumper and the truck bed.
12. Connect the short wire harness to the long wire harness. Locate the connector so that you can reach it to remove the tailgate. Coil and tie the extra length of the short wiring harness inside the tailgate. Don't attach it to the truck.
13. Route the long wire harness along the frame rail and the existing wiring on the driver's side of the truck. Use cable ties to attach the harness to the existing wiring underneath the truck. Follow the existing wiring under the cab and up the firewall to the grommet at the hood-release cable.
14. Pull the wires through the grommet and lead them to the blue connectors you attached to the wiring in Step 5. The system is now fully installed. CLOSE THE TAILGATE. Perform a final check and reverse the wires if necessary.