

Contents:

Lock Bracket, 2 keys
EL Bracket, Bolt Assembly
Instructions, Warranty Card

Tools Required:

T-30 Torx Driver, 10 MM Socket
Screw Driver

Tech Support:

Call 1-800-342-5911

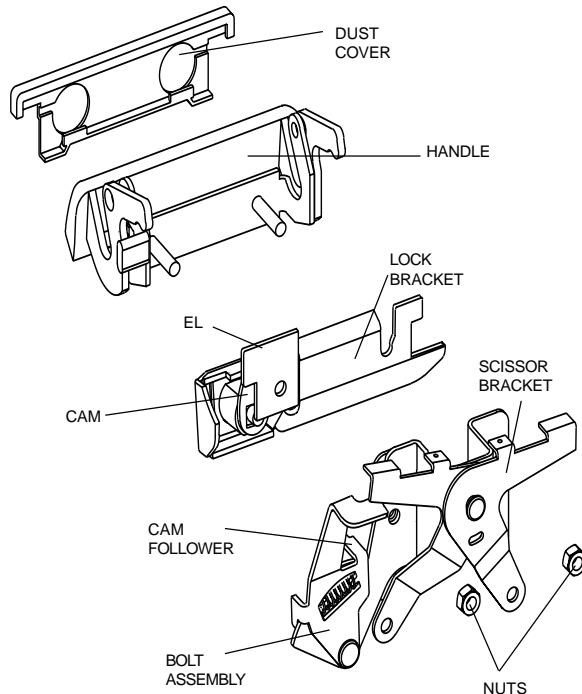

NOTE: POP&LOCK is designed to secure the passenger side latch. You may experience that the drive side latch can open due to the flex in the handle, but the tailgate will still remain locked.

Installation

1. Lower the tailgate and remove the access panel with a Torx T-30 driver.
2. Release the rod ends from the plastic clips of the scissor links by prying the yellow clasps up with a screw driver.
3. Remove the two 10 MM nuts holding the scissor bracket and remove it and remove the handle.
4. Pry the plastic dust cover from the handle and discard it.
5. Slide the LOCK BRACKET over the driver's side stud on the handle and slide the EL over the passenger's side stud of the handle.
6. Insert them into the tailgate from the outside.
7. Insert the scissor bracket into the tailgate from the inside. Tighten it down with a nut on the driver's side.
8. Turn the lock counter clockwise with the slot in the horizontal position. This is important for the next step.
9. Insert the BOLT ASSEMBLY and position it onto the driver's side stud on top of the scissor link with the other nut.
10. Turn the key and check that the CAM FOLLOWER is riding on the CAM and opening and closing the BOLT fully.
11. If necessary, reposition the BOLT ASSEMBLY to make sure the cam follower is positioned properly.
12. Tighten the passenger's side nut.
13. Reinsert the rods. Position them so there is a 1/32 play before they pull the latches. Close the yellow clasps to lock them into place. Check for proper play. Reposition the rods if necessary. Reinstall access panel.

