

PM1

UNIVERSAL PROJECTOR MOUNT

PRODUCT FEATURES PROJECTOR MOUNT

rotates 360° and has adjustable 0–10° tilt
opens from 10"–24" (left to right)
opens from 4.5"–7.75" (top to bottom)
clamping mechanisms adjust from
8"–11.75" front to back
flush mountable
load capacity 75 lbs.
black finish

PRODUCT SPECIFICATIONS FOR ARCHITECTS & ENGINEERS

The universal ceiling mount for LCD projectors shall be a Video Mount Products (VMP) model VMP-PM1 ceiling mount. The mount is constructed primarily of tubular steel and shall incorporate nylon filled nuts and arc welds. The mount shall be designed to allow adjustable tilt up to a maximum of $\pm 10^\circ$ and shall swivel 360°. It shall be capable of supporting the weight and adjusting to the dimensions of a variety of LCD projector manufacturers. The projector mount shall open from 10" to 24" (left to right) and open from 4.5" to 7.75" (top to bottom). The mount shall include a telescoping ceiling mast adjustable from 18" to 30". The mount shall have an integrated clamping mechanism that will secure the projector on all sides. The clamping mechanism shall also adjust independently from 8" to 11.75" (front to back). The projector mount shall also have the ability to be flush mounted to the ceiling on 12" and 16" centers. The load capacity shall be 75 lbs. The mount shall be UL listed in the United States and Canada.

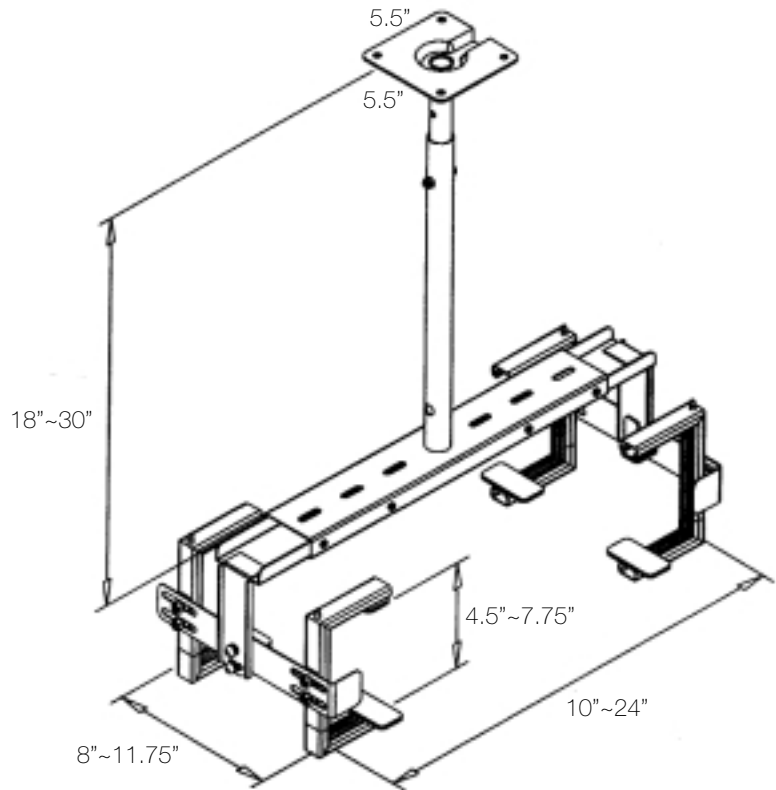

VMP Mounting Systems for
Video, Audio & Security
Video Mount Products

UL LISTED