

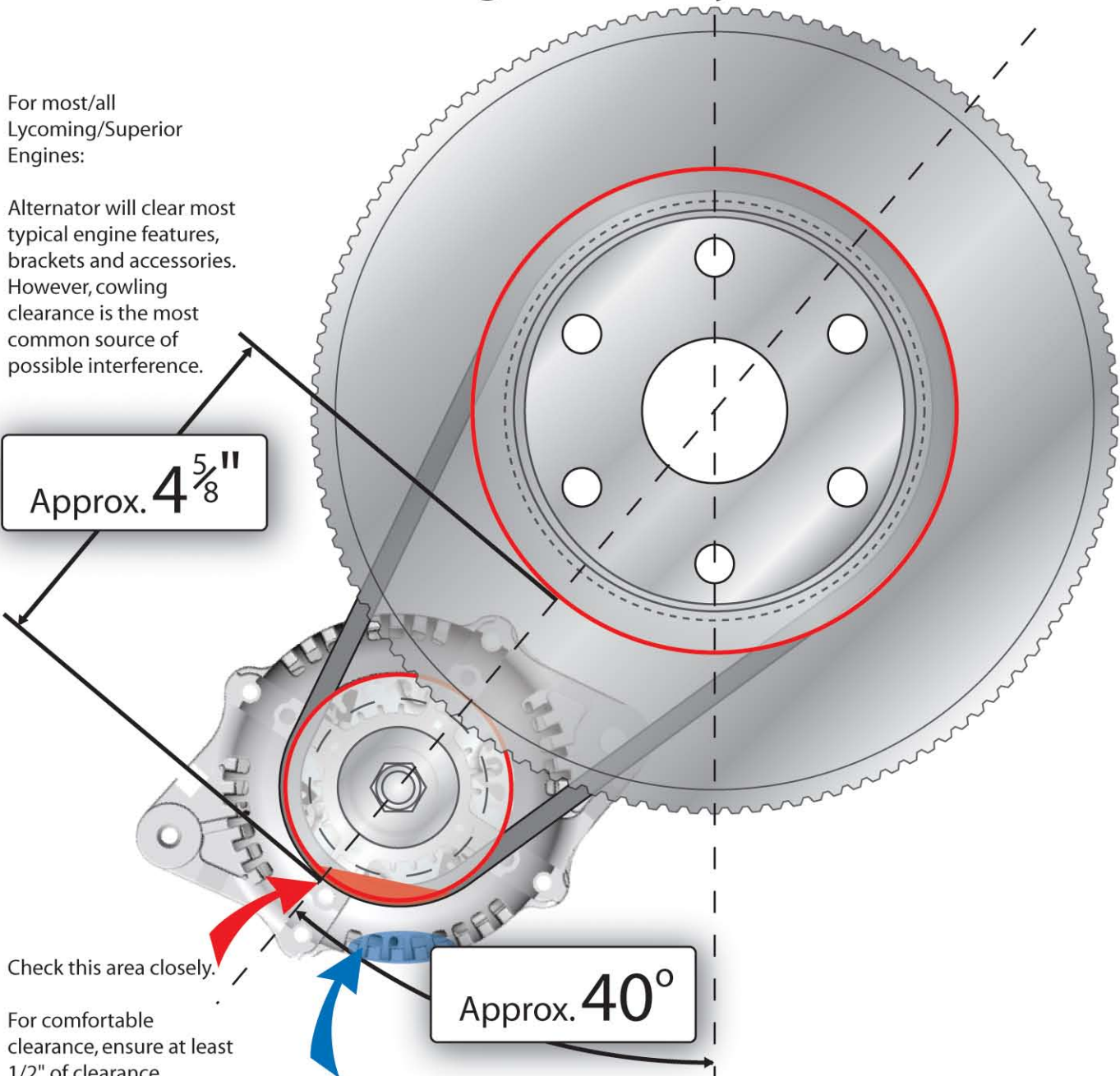

Measuring for Proper Alternator Fit Experimental 60 Amp Models with 7-1/2" Diameter Engine Pulleys

For most/all
Lycoming/Superior
Engines:

Alternator will clear most
typical engine features,
brackets and accessories.
However, cowling
clearance is the most
common source of
possible interference.



Check this area closely.
For comfortable
clearance, ensure at least
1/2" of clearance
between the bottom
edge of the alternator
pulley and the inside of
the cowling (including
landing lights, ducts,
scat, etc.).

The bottom forward edge of the alternator
(stator housing) is a less likely source of
interference. However, if you have a concern,
please refer to product drawings for the location
of offsets relative to the critical pulley area
shaded above.

**MODEL
AL12-EI60
SHOWN**