

Vehicle reversing sensor module
Ultrasonic obstacle detection system
at 12 and 24 volts

Installation notes

Installation is possible on all types of vehicles with 12 and 24V power supply with negative earth. The unit must be installed inside the vehicle. Carefully read the following instructions and technical specifications. For installation, follow the instructions shown in the Operator's and maintenance booklet of the vehicle. Products manufactured taking into account the essential technical requirements of European Directive 95/54/EC.

- The parking sensor is an aid to vehicle reversing operations during parking. Not all objects are detected by the sensor and consequently reversing operations must be performed with the utmost care and attention.
- Reversing speed must never exceed 6 km/h
- Stop the vehicle when the buzzer sounds continuously as this indicates an obstacle at not more than 45 cm from the vehicle.
- Perform connection operations only AFTER having disconnected the vehicle battery.
- The unit must only be installed by a professional installer.
- Any changes or additions made to the system and not expressly shown in this manual shall invalidate the warranty
- Clean the sensors regularly. For example, snow or dust can reduce efficiency
- In the event of washing with high-pressure water jets, the sensors could temporarily lose part of their sensitivity. This will return once the water has completely evaporated.
- Do not position the unit, the sensors or the cables near heat sources such as the vehicle engine or exhaust.

Contents of sections

Technical specificationsA
Wiring diagramB
Sensor installationC
Optional accessoriesD
TroubleshootingE

TECHNICAL SPECIFICATIONS

Description	MIN	TYPE	MAX	UNIT
Power voltage	10		27	V
Standby current		100		mA
Operating current		200		mA
Operating temperature	-25		80	°C
Storage temperature	-30		85	°C
Operating frequency	38	40	42	KHz
Horizontal detection angle		120		°
Vertical detection angle		60		°
Distance detection accuracy		± 5		cm
Max detection distance		1.5		m
Buzzer sound power	90		105	dB

Operation

This parking sensor has been designed using the most recent detection and ultrasonic technologies and helps the driver in parking and reversing operations. System sensitivity is automatically adapted. For correct sensor installation, always carefully follow the instructions in this manual. The distance from an obstacle is indicated by means of intermittent beeps which start when the distance from the obstacle is around 1.5 metres. As the obstacle comes closer, beep frequency increases and becomes continuous when the distance is around 45 cm.

WIRING DIAGRAM

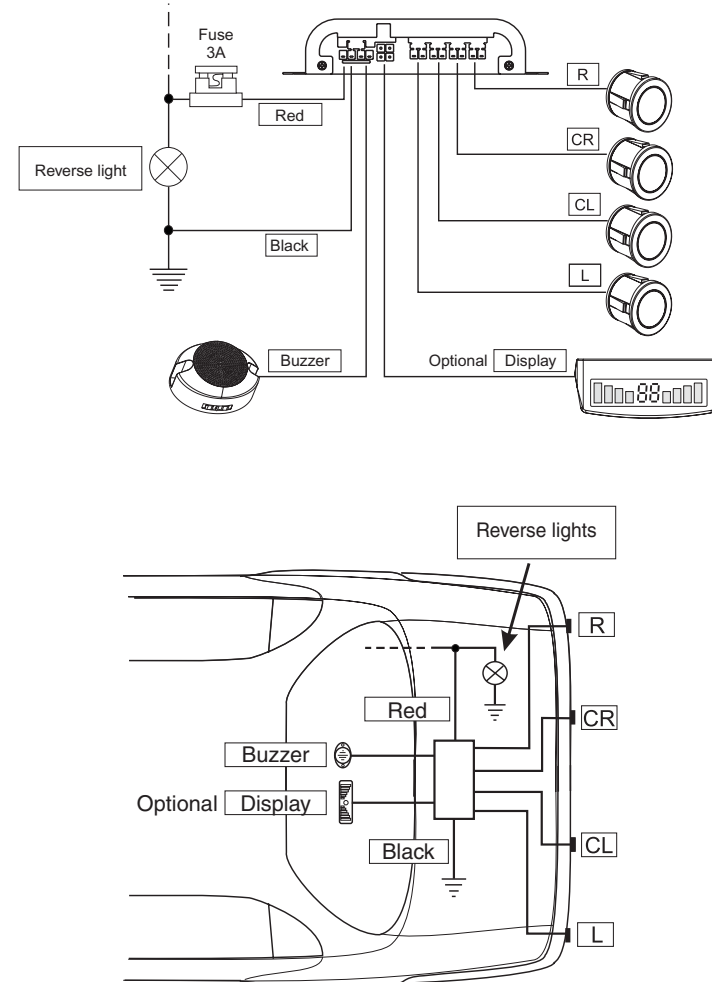

WIRING DIAGRAM

Connect the RED wire to the positive of the reverse lights (+12V when the reverse gear is engaged)
Connect the BLACK wire to the earth
Connect the buzzer. The sound volume can be regulated on two levels by means of the hi-lo-off switch.
Connect the capsules, following the instructions in drawing 2.

A

Sensor connection

PS4

Code 3560.0025
Code 3560.0029
Code 3560.0032

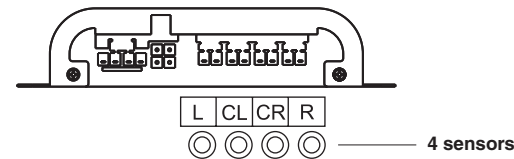

PS3

Code 3560.0024
Code 3560.0027
Code 3560.0031

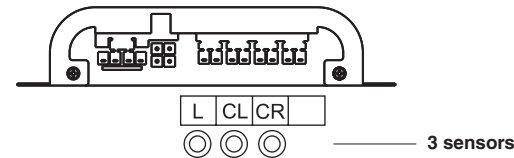

PS2

Code 3560.0023
Code 3560.0026
Code 3560.0030

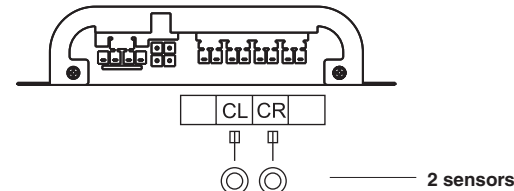

STANDARD SENSOR INSTALLATION (CODE 6006.1031)

C

Positioning

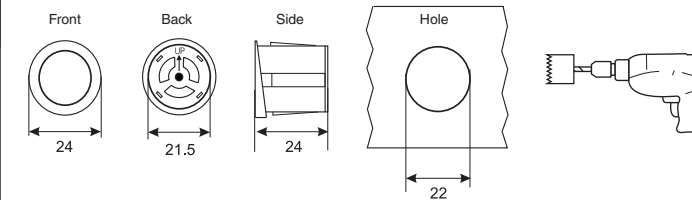

Fitting the sensors on the Rear bumper

PS4

Code 3450.0025
Code 3450.0029
Code 3450.0032

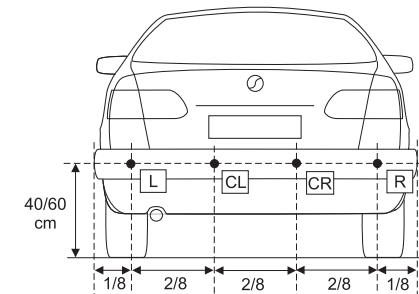

PS3

Code 3450.0024
Code 3450.0027
Code 3450.0031

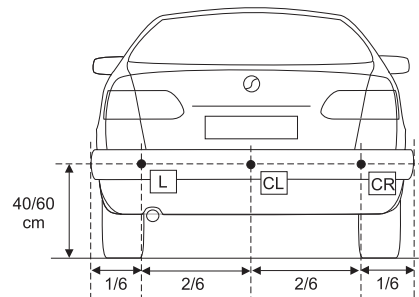

PS2

Code 3450.0023
Code 3450.0026
Code 3450.0030

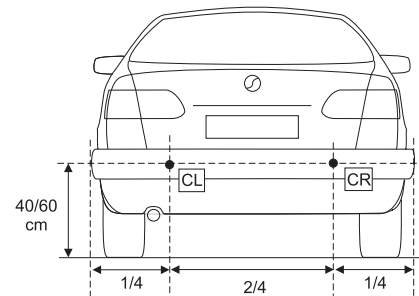

Vertical angle

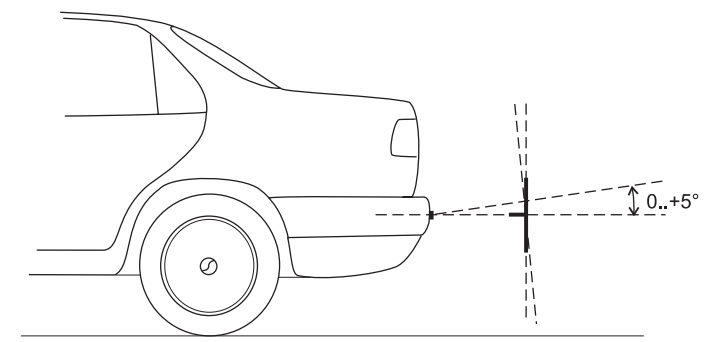

OPTIONAL ACCESSORIES

D

Flat sensors
Code 6006.1032

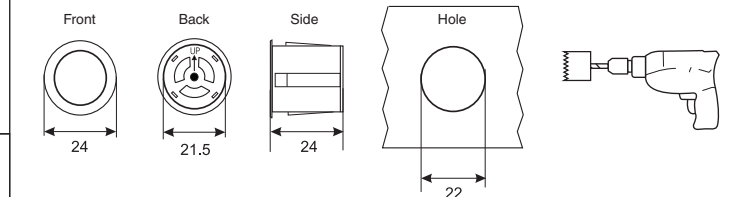

Sensors with rubber support
Code 6006.1033

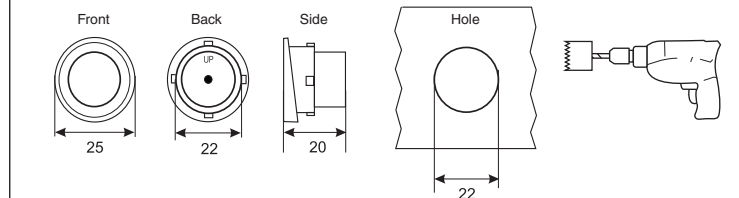

Display unit

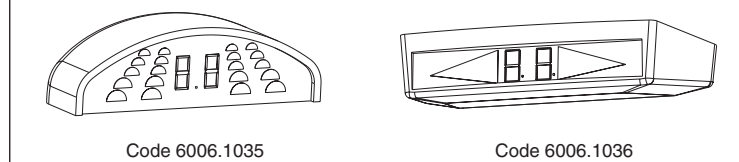

TROUBLESHOOTING

E

TROUBLESHOOTING GUIDE

PROBLEM	CAUSE	REMEDY
The system fails to start when the reverse gear is engaged	Wrong red and black power wire connection.	Check the power circuit.
	Wrong connector connection.	Check the connectors.
The system always detects the same distance	The sensors are reading the ground	Check and adjust vertical sensor angle
The system fails to detect obstacles	Wrong sensor connection.	Interrupt power to the system and check sensor connection
The signal gives false signals	The sensors are reading the ground	Check and adjust vertical sensor angle