

ReverseGUARD Installation Instructions and Users Guide

Product Specifications

ReverseGUARD[®] is a unique obstacle detection system developed in the USA and patented by American Road Products, Inc. This backup alert/reverse-sensing system uses the latest ultrasound technology to detect objects that are up to eight feet from the rear of the vehicle. The system uses proprietary object detection software. Input power is by DC12V obtained through the output of the vehicle's backup light.

Sensors and Coverage Area

The ReverseGUARD[®] system uses four ultrasound sensors built into a patented license plate frame design. Two sensors are located 5" apart and are angled to optimize coverage. The other two sensors are located on each side of the unit. The four sensors combined provide a field of coverage approximately equal to the width of a standard automobile and back a distance of 6' to 7' (8 feet maximum) from the unit.

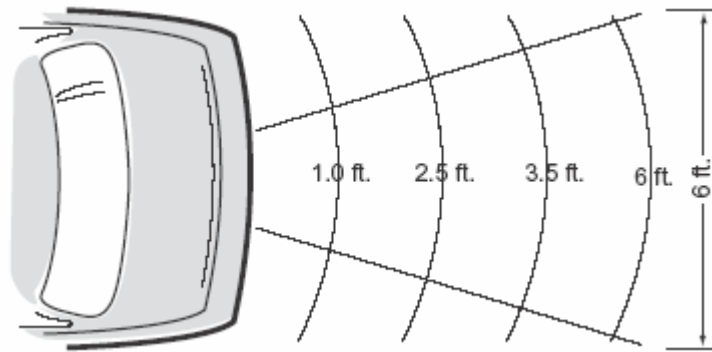

Alarm / Distance from Obstacles

A beeping warning alarm sounds inside the vehicle. The alarm signal becomes more frequent (rapid) as the vehicle and the object get closer to each other, such as shown on the following chart. If your system is equipped with an LED distance display, the display will provide a numeric distance indicator and a dual color band that depicts relative distance. You may monitor the color indicator to determine on which side of the vehicle an object is detected. The indicator will show Red nearest the back of the car, Yellow in the middle range, and Green at the outer range.

Approx. Distance from Obstacle	Inside-Vehicle Warning Alarm
3.5 -8.0 feet	beep...beep... (slow)
2.5 -3.5 feet	beep..beep..beep.. (medium)
1.0 -2.5 feet	beep.beep.beep.beep. (fast)
0.0 -1.5 foot	beeeeeeeeeeeep (constant)

Installation of the ReverseGUARD[®] System

The Standard orientation of the ReverseGUARD[®] unit is with the sensors at the top of the frame. However, the unit may be positioned with the sensors at the bottom of the license plate. The better orientation will be dictated by vehicle style. If the sensors are positioned at the bottom, please note below the special installation instructions for the connection of the wiring to the Control Box. Follow these steps to install ReverseGUARD:

1. Measure the distance from the top of the license plate to the ground. If the distance is greater than 36" the sensors should generally be mounted in the lower position.
2. Determine if the license plate is recessed. If you have a recess that varies in depth, your system should be mounted with the sensors adjacent to the lesser depth. If your recess is more than 5" deep and narrower than 18" you may have problems with the installation.
3. On some vehicles, especially SUV's, the rear door handle may require that the sensors be mounted at the bottom of the plate. On all vehicles, take care to assure that the sensors are not hidden by trim on the vehicle.
4. In considering the mount, it is important to note the angle of the surface to which the license plate attaches. If the angle causes the sensors to tilt upwards, it will be necessary to create an angle sufficient to tilt the sensors 3^o to 5^o downward. NOTE: An angled backing plate is provided in the installation kit to be used if necessary to create a slant of the ReverseGUARD[®] unit. This backing plate can be used to angle the top or bottom of the unit. The backing plate is not needed for all installations and use of the backing plate is optional.
5. Although not generally necessary, you may choose to create a notch (for wires to pass by) at the top or bottom of the license plate (depending on orientation of unit). The notch will be about ¼ inch deep and ¼ inch wide. Using pliers, carefully bend the notched section back behind the plate. The ReverseGUARD unit will cover the notched area.

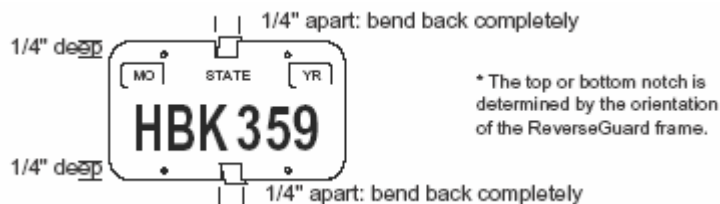

6. Find a (concealed) location inside the trunk area of the vehicle to mount the Control Box. This location should be within 3' of either backup light in order to make the necessary electrical connection.

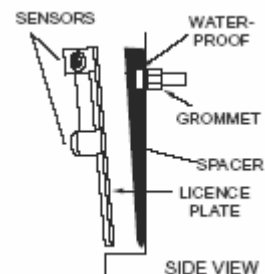

IMPORTANT: Avoid placing the Control Box next to any other electrical equipment or heavy wires that carry an electrical current as it may interfere with the functioning of the sensor system.

7. Feed the wires from the ReverseGUARD[®] unit through the vehicle to the Control Box. Neatly conceal the wires under existing molding, carpeting and/or insulation. Some vehicles may require the drilling of a ½ inch hole behind the license plate to allow the wires to pass through. (A grommet is provided (on the wire harness) to plug this hole.)

8. Mount the ReverseGUARD[®] unit and license plate to the vehicle using four screws and spacers or spacer back plate (if necessary).

Connecting ReverseGUARD[®] to the Control Box

IMPORTANT: Each of the wires uses quick connectors to attach to the Control Box. Use a firm push, but do not force the connectors into the respective sockets. Be careful to not dislodge any of the wires from the connectors.

1. Insert the 4-pin connector from the (piezo) Speaker to the Control Box Power Receptacle. This also provides the connection to the vehicle power line. Note that the bare wires will connect to power and ground at the backup light as described in Step 3 below. If your system uses an LED Display in addition to the Speaker, you will also connect the 3-pin connector to the 3-pin slot in the Control Box.

2. **IMPORTANT:** If your system uses a piezo speaker only and no LED display, please use the installation procedure noted in A below. If your system came equipped with an LED, use installation procedure B below.

Procedure A (Speaker Only System): Connect the four color coded signal wires from the ReverseGUARD[®] unit into the Control Box, taking care to color match each wire with the appropriate connector.

Procedure B (Speaker and LED System): IF your system is mounted with the sensors at the TOP of the frame you will follow Procedure A as noted above. IF your system is mounted with the sensors at the BOTTOM of the frame, make the following connections:

- ❖ Sensor R1 (Yellow) to Control Box L2 (White)
- ❖ Sensor R2 (Blue) to Control Box L1 (Red)
- ❖ Sensor L1 (Red) to Control Box R2 (Blue)
- ❖ Sensor L2 (White) to Control Box R1 (Yellow)

3. Locate the 12V power wire and the ground wire behind the reverse light bulb on the vehicle and connect them to the red and black wires from the Power Line using the connectors provided.

The color of wires on vehicles may vary. Connect power to power and ground to ground. **IMPORTANT:** It is necessary to use the ground from the backup light and not a separate ground.

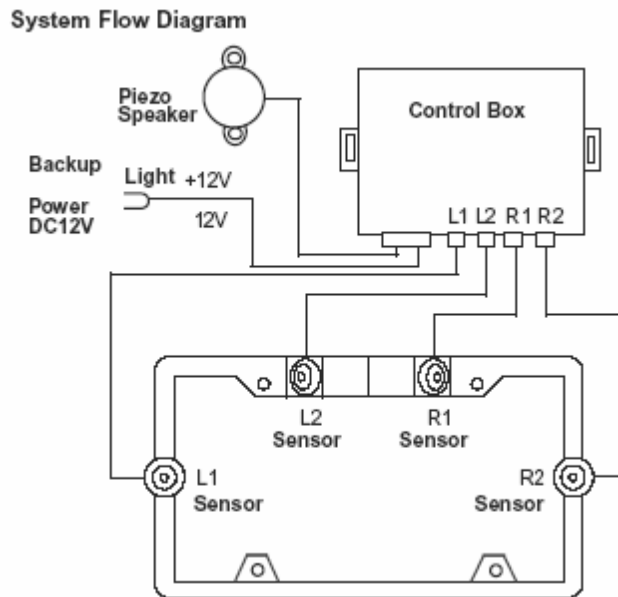

Installation of the Control Box and (piezo) Speaker and LED Display (if provided)

1. Secure the Control Box to the vehicle using the screws or two-sided tape (provided). **IMPORTANT:** Make certain that this location is away from excessive heat and moisture and heavy sources of power, such as a car battery or other electronics.
2. Find a suitable location in the rear of the vehicle to secure the Speaker using two screws or two-sided tape (provided). You can mount the speaker under an existing speaker grill. **IMPORTANT:** Make certain that the Speaker is clearly heard under normal driving conditions. If necessary, this wire can be lengthened to extend the Speaker to the front or cab area of the vehicle.
3. Note that the LED, if provided with your system, is generally mounted at the front of the vehicle, visible to the driver. If you choose to mount it at the rear of the vehicle to be viewed through the rear view mirror, the numeric indicator will not present properly. If you chose this mounting, you must use the following instructions; else the image you see in the mirror will be the reverse of actual object representation: **IMPORTANT:** If your system is mounted with the sensors at the TOP of the frame you will follow procedure B in the connection section on page 3. If your system is mounted with the sensors at the BOTTOM of the frame you will follow procedure A in the connection section of these instructions.

Supplemental Instructions for Pick-up Trucks

These are supplemental instructions only. Please follow all basic installation procedures, taking note of the following exceptions:

1. Remove the tail light assembly from one side of the vehicle.
2. Drill a ½ inch hole if necessary to pass the bundle of black wires from the ReverseGUARD unit into the area of the tail light assembly. The rubber grommet on the wire harness should be used to seal the hole.
3. Select a suitable location in the area of the tail light assembly to secure the control box using screws or two-sided tape or other fasteners. Connect the sensor wires and (piezo) speaker wire.
4. Attach the two (2) wires from the power source to the appropriate wires at the backup light, power to power and ground to ground, using the actual backup light ground.
5. It will be necessary to bring the small (piezo) speaker into the vehicle cab. If the speaker wire is not long enough to extend into the vehicle cab, you may splice an additional length of wire, as necessary. **IMPORTANT:** This is the only wire that may be lengthened. The sensor wires must not be shortened or lengthened.

Testing and Troubleshooting

It will be helpful to have an observer assist you in testing the unit. To test the unit, it will be necessary to start the vehicle and engage the reverse gear. With an observer beside the vehicle, begin to back slowly towards a wall or other similar obstacle. Starting at 6-8 feet you will begin to hear an intermittent beeping alarm inside the vehicle. As you approach the object, the sound will transition to a more rapid beep then to a continuous alarm at about 1 foot from the obstacle. If the unit is not working properly, please review the following troubleshooting suggestions:

1. Double-check all connections. Be sure that all connectors are firmly seated. Be sure that a wire has not been pulled loose from the connector.
2. Check your ground connection. Be sure the ground from the reverse light to the power box is properly made. It is very important that the ground wire used for the reverse light be used and that the unit not be grounded elsewhere to the vehicle.
3. Be sure that the control box is not located near any other sources of power such as heavy cables that carry an electrical signal, other computer boxes, or a vehicle battery. This will interfere with the signal.
4. Be sure that the sensors are properly oriented. This will depend on the height of the installation. If the plate (sensor unit) is high off the ground, or if the angle of the license plate mounting is too high upwards, the sensors may not be aimed near enough to the ground. The unit should be level on lower mounted installations, and aimed about 5 degrees down on higher

mounted installations. With very low bumper mounted license plates the upper orientation of the sensors may be best in order to avoid picking up the "ground" as an object. This will cause the system to create a false positive.

5. Note that the ReverseGUARD unit is designed for standard license plate installations and bumpers with minimal recess, i.e., 1"-3" maximum. If the recess is deeper, the sensors may be picking up the edge of the bumper and giving a false signal. This is often the problem with false signals on deeply recessed bumper mountings, and mountings that are narrow such as the step bumper found on some trucks or SUV's.

6. Check the voltage of the power going into the control box. If you are getting a steady but intermittent (slow) signal with no objects present, this may be indicative of an "error message" that the control box processor is not getting sufficient voltage to operate properly. The ReverseGUARD System is designed to operate with 12 volts of power coming into the control box but will generally operate with 11 volts.

7. For further assistance, call American Road Products, Inc. at (888) 918-8800.



IMPORTANT INFORMATION **When Using ReverseGUARD[®]**

ReverseGUARD[®] is a device engineered to assist drivers when backing the vehicle. It is not a collision avoidance device and has no connection to the vehicle's braking system. It is a parking aid and will not assure safety when backing a vehicle. The driver remains responsible for using caution at all times, including when backing up.