

hang^{it}up!

Centralized cleaning convenience for garage, workshop, hobby area, laundry room or anywhere a hands free vacuum center is desirable.

Complete with wall mount bracket and an 18' extra reach hose for wide area cleaning.

Space saving "hang-up" design provides a cleaning solution that's there when you need it.

Features

- Wet or dry vacuum cleaning.
- Quiet operation.
- Efficient cartridge filter.
- Space saving wall mount is easy to install.
- Powerful 4.5 HP (peak) motor.
- Easy removal from wall bracket for emptying or portable use.
- Tool storage.
- Top handle for easy handling.
- Extra large capacity container.
- Three year warranty.

Performance

- Electrical
- 120V~
 - 60Hz
 - 8.0 Amps
 - CFM 165
 - S.P. 57"
 - Air Watts 325



shop·vac[®]
hangup[®]
PRO

W E T • D R Y • V A C

shop·vac[®] hangup[®] PRO

W E T • D R Y • V A C

Features

- ¥ Wet or dry vacuum cleaning
- ¥ Quiet operation
- ¥ Efficient cartridge filter
- ¥ Space saving wall mount is easy to install
- ¥ Powerful 4.5 HP (peak) motor
- ¥ Easy removal from wall bracket for emptying or portable use
- ¥ Top handle for easy handling
- ¥ Extra large capacity container
- ¥ Three year warranty

Accessories

- ¥ 18' x 1 1/4" Lock-On™ Hose
- ¥ 2 - 1 1/4" Extension Wands
- ¥ 12" Deluxe Floor Nozzle w/ Brush and Squeegee
- ¥ Round Brush
- ¥ Crevice Tool
- ¥ Gulper Nozzle
- ¥ Wall Mount Bracket
- ¥ Tool Holder
- ¥ Cartridge Filter (replacement # 903-98)
- ¥ Foam Sleeve (replacement # 905-26)

Performance

- Electrical
- ¥ 120V~
 - ¥ 60Hz
 - ¥ 8.0 Amps
 - ¥ CFM 165
 - ¥ S.P. 57"
 - ¥ Air Watts 325

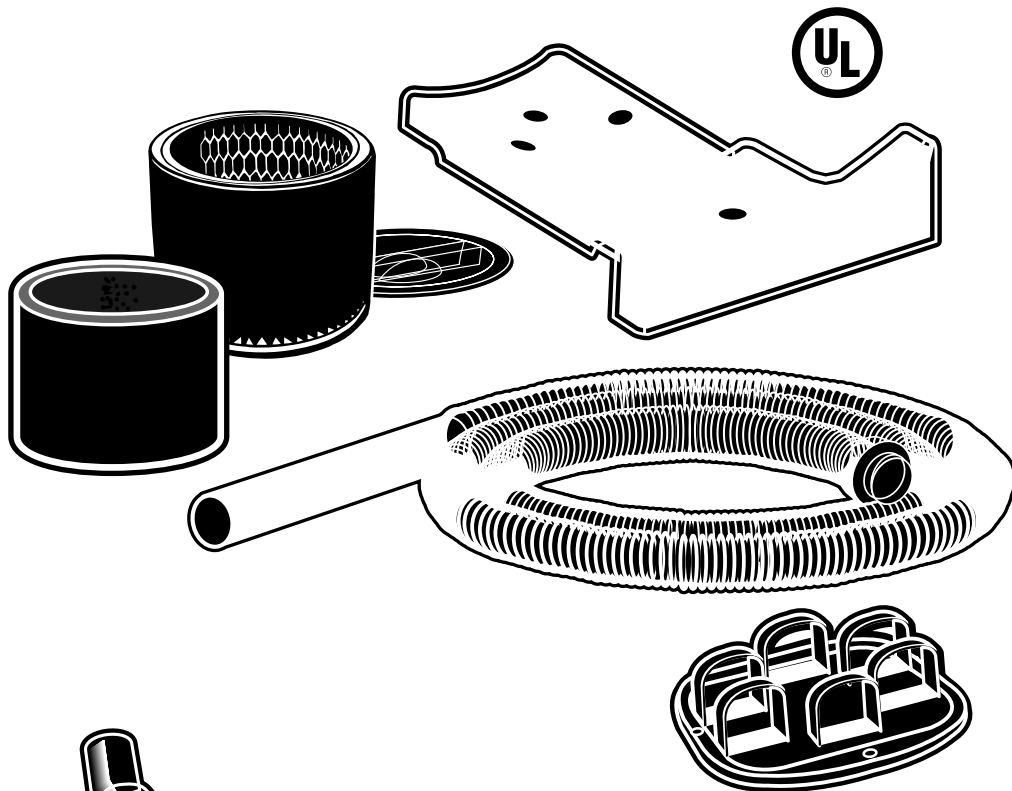

9520262

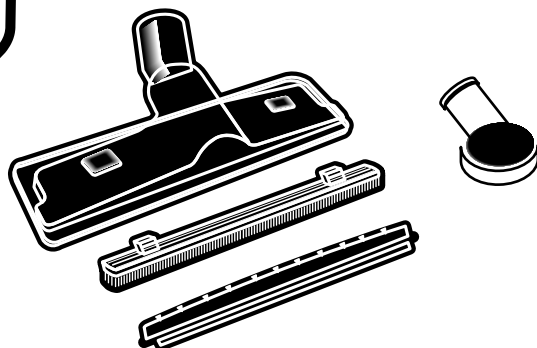

5 Gallon
4.5 HP (peak)