



# PRODUCT SPECIFICATION

## EH4007/EH4010/EH4014/EH4018 Enclosure INDOOR, SMALL-TO-MEDIUM



### Product Features

- Low Cost
- Indoor Applications
- Contemporary Design
- Small-to-Medium Sizes
- For use with Fixed Mount or Pan/Tilt
- Design for use with Solid-State/CCD Type Cameras
- Easy Access for Service and Installation

The **EH4000 Series** are low cost camera enclosures, designed especially for use with solid-state CCD type cameras in indoor environments.

The enclosure features a removable rear cap for easy access to camera sled. Adjustable glands on the rear cap allow for easy installation of the power and video cables, and a removable front cap allows the installer to manually adjust the lens without removing the camera.

The **EH4007** is supplied with a ceiling mounting bracket as a standard feature and is primarily designed for vertical format CCD type cameras. The **EH4010** is designed for use with 1/2-inch format cameras and the **EH4014/EH4018** are for use with 2/3-inch format cameras. The **EH4014/EH4018** will accommodate fixed focal length lenses or motorized zoom lenses (with or without auto-iris).

The **EH4010/EH4014/EH4018** can be used in fixed mount applications or mounted to a light duty pan/tilt such as our PT280 Series.



EH4007



EH4014

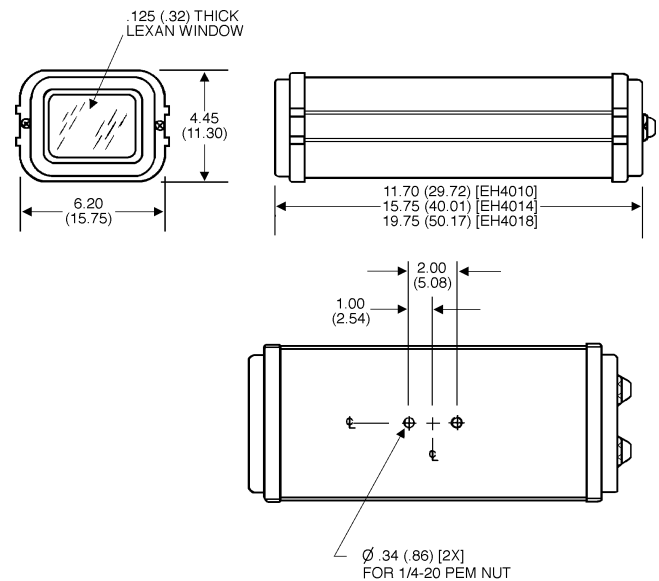

NOTE: VALUES IN PARENTHESES ARE CENTIMETERS; ALL OTHERS ARE INCHES.

EH4010/EH4014/EH4018 DIMENSION DRAWING



# TECHNICAL SPECIFICATIONS

## MODELS

EH4007	Extruded aluminum enclosure, 8.70" (22.09 kg) body length, for vertical format cameras. Includes mounting bracket
EH4010	Extruded aluminum enclosure, 11.70" (29.71 kg) body length, for 1/2-inch format cameras
EH4014	Extruded aluminum enclosure, 15.75" (40.01 cm) body length, for 2/3-inch format cameras with fixed focal length or motorized lenses
EH4018	Same as EH4014 except 19.75" (50.16 cm) body length

## MECHANICAL

Camera Mounting EH4007/EH4010	Adjustable L-shaped bracket with one mounting hole attached to the slide-out rail
EH4014/EH4018	Multiple holes on removable camera sled
Maximum Camera and Lens Size	Accepts camera and lens combinations (including BNC connector) up to:
EH4007	4.25" H x 3.00" W x 5.00" L (10.79 cm x 7.62 cm x 12.70 cm)
EH4010	3.50" H x 5.25" W x 8.00" L (8.89 cm x 13.33 cm x 20.32 cm)
EH4014	3.50" H x 5.25" W x 12.00" L (8.89 cm x 13.33 cm x 30.48 cm)
EH4018	3.50" H x 5.25" W x 16.00" L (8.89 cm x 13.33 cm x 40.64 cm)
Viewing Window	.125" (3.17 mm) thick, optically clear, UV stabilized, impact-resistant Lexan (UL 94HB rated)
Viewing Window Area	
EH4007	3.75" H x 2.50" W (9.52 cm x 6.35 cm)
All Other Models	2.50" H x 3.75" W (6.35 cm x 9.52 cm)
Cable Entry	Two compression glands on rear cap; maximum 5/16" (.79 cm) cable diameter

## GENERAL

Construction	Extruded aluminum body; injection molded black ABS plastic end caps	
Finish	Gray polyester powder coat	
Environment	Indoor only	
Dimensions	See dimension drawings	
Weight	Unit	Shipping
EH4007	2 lb 12 oz. (1.25 kg)	4 lb (1.81 kg)
EH4010	3 lb 8 oz. (1.59 kg)	5 lb (2.26 kg)
EH4014	4 lb 4 oz. (1.91 kg)	6 lb (2.7 kg)
EH4018	5 lb (2.25 kg)	7 lb (3.15 kg)

## CERTIFICATIONS

- ◆ UL listed to Standard 2044
- ◆ CE compliant

## OPTIONAL ACCESSORIES

LK4000	Tamper-proof screw kit. Includes 100 tamper-proof screws and one (1) insertion/removal tool
--------	---

## RECOMMENDED MOUNTS

(Not applicable to EH4007 enclosure.)

### Ceiling/Pedestal

EM1009U, EM1015U	Medium duty ceiling/pedestal mount. Max. load 40 lb (18.12 kg). (See C202 spec)
EM3000	Ceiling "J" mount. Max. load 40 lb (18.12 kg). (See C262 spec)
MM22	Medium duty ceiling/pedestal mount. Max. load 40 lb (18.12 kg). (See C227 spec)

### Wall

EM1400	Light duty wall mount. Max. load 20 lb (9.06 kg). (See C260 spec)
EM1900U	Medium duty wall mount. Max. load 40 lb (18.12 kg). (See C202 spec)
EM2400	Light duty wall mount. Max. load 20 lb (9.06 kg). (See C260 spec)
EM22	Medium duty wall mount. Max. load 40 lb (18.12 kg). (See C227 spec)

### Pipe/Pole

EM1109	Medium duty pedestal mount for vertical pipe or pole applications. Max. load 40 lb (18.12 kg). (See C207 spec)
EM2000	Medium duty mount for vertical pipe or pole applications. Max. load 40 lb (18.12 kg). (See C207 spec)
EM2200	Medium duty mount for horizontal pipe or pole applications. Max. load 40 lb (18.12 kg). (See C207 spec)

## RECOMMENDED PAN/TILT

PT280 Series	Light duty pan/tilt, 24 VAC. Maximum load 15 lb (6.81 kg). (See C324 spec)
--------------	--

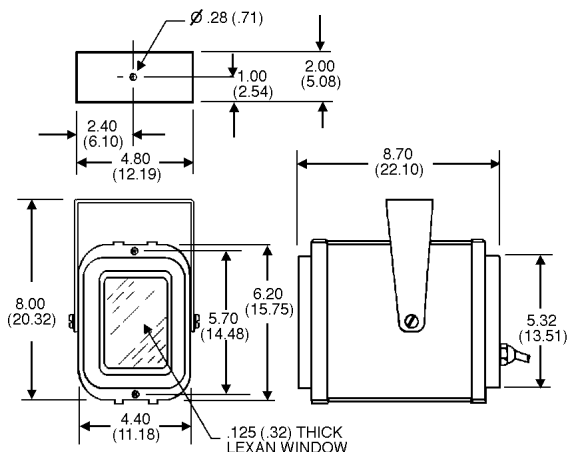

NOTE: VALUES IN PARENTHESES ARE CENTIMETERS; ALL OTHERS ARE INCHES.

EH4007 DIMENSION DRAWING

Specifications subject to change without notice. ©Copyright 1997, PELCO. All rights reserved.