

# OWNER'S MANUAL

**Stromberg Carlson Products, Inc**

Manufactured by Lippert Components of Goshen, IN

## COACH STEP

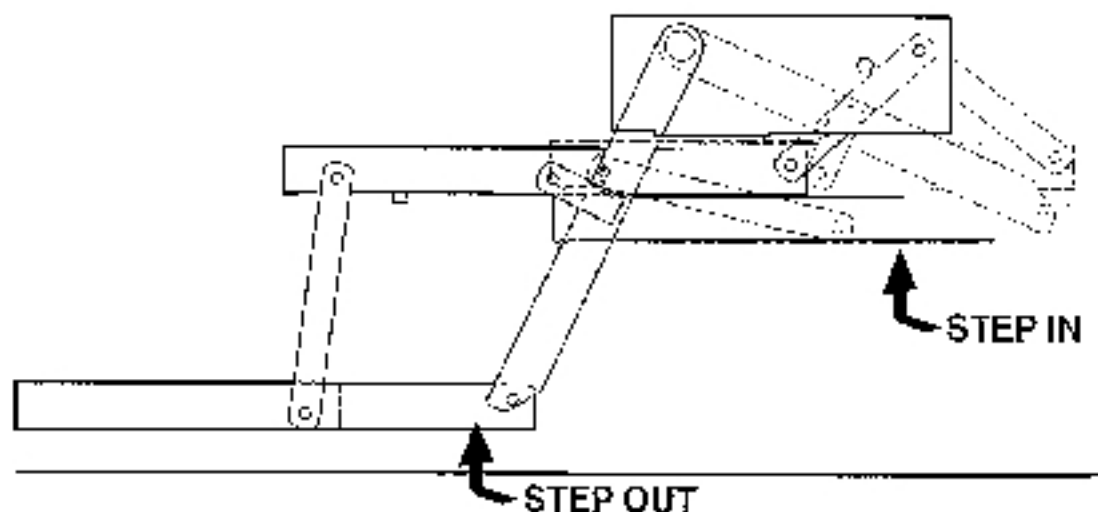

**The Safe & Reliable Automatic Electric  
Stair For Recreational Vehicles**

# OWNER'S OPERATING INSTRUCTIONS

**CAUTION:** Look before you exit.

As it is possible to deliberately lock the steps up with the rocker switch, passengers should always be cautioned to be sure the steps are fully deployed before exiting the motor home.

## WITH THE POWER SWITCH "ON"

Open the door and the steps will extend and lock in the down position. The amber entry lamp will turn on automatically.

Closing the door will shut off the light and will cause the steps to retract.

**CAUTION:** With the power switch ON, steps extended, and door open, it will be possible to start the vehicle and drive away with the steps extended. This combination of events is discouraged since damage to the steps and vehicle is possible.

## WITH THE POWER SWITCH "OFF"

If the steps are extended with the door open and the power switch is then turned OFF, the steps will remain extended. The amber light will go off.

If the steps are retracted when the power switch is turned OFF, the steps will remain retracted.

With the power switch OFF, the steps extended and the door closed, turning on the ignition will cause the steps to automatically retract. This feature reduces the possibility of the vehicle being driven with the steps extended.

After the ignition is turned OFF, and the door is opened, the steps will extend one time only. This is known as the "last man out" feature.

If the door is opened and closed without allowing the steps to fully extend, the step will retract and will stay in that position until the power switch is turned ON and the door is reopened.

## OPERATION NOTE:

If the step encounters an immovable obstacle such as a curb, they will stop and shut down in that position, they will retract normally when the door is closed.

# PREPARATION FOR INSTALLATION

**WARNING: STAY CLEAR OF THE EXTENDING STEPS; DEPLOYMENT TAKES APPROXIMATELY TWO SECONDS. KEEP HANDS AND FINGERS CLEAR WHILE EXTENDING OR RETRACTING.**

- ① The steps will install easier if they are first extended. Place the step upside down on a bench or on the floor.
- ② Connect (4) short jumper wires to the 4-Pin connector. Match them color for color. (Fig. 1).
- ③ Attach the green ground wire to the negative post of a fully charged 12 volt automotive battery.
- ④ Attach both the red and white wires to the positive terminal of the battery.
- ⑤ Ground the brown wire to the negative battery terminal. The steps will immediately extend.
- ⑥ Disconnect the wires from the battery.

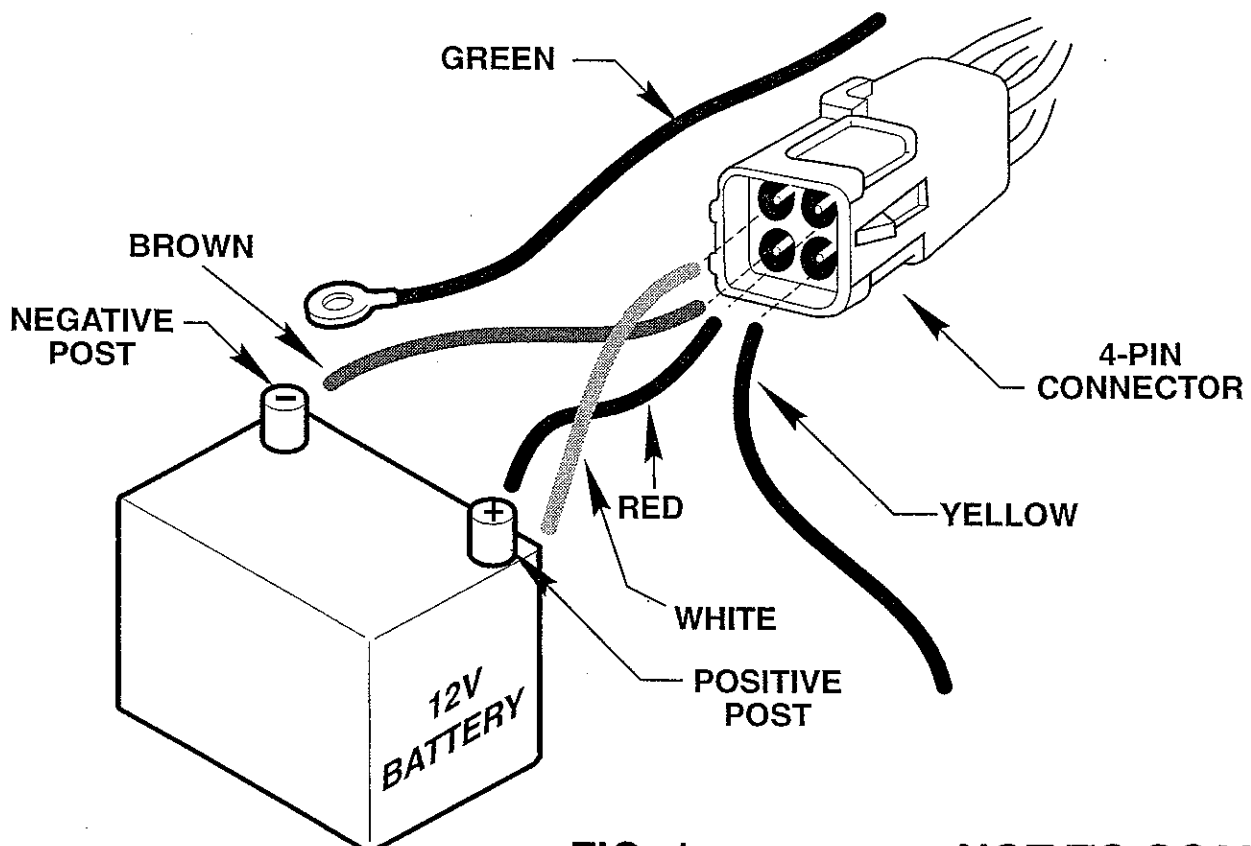

FIG. 1

NOT TO SCALE

## SERVICE NOTES

A. Use locktite on any bolts removed and replaced.

Note: The shoulder bolts used to hold the joints together have a nylok patch. However, it is recommended that if the nut is removed and replaced in the field, a liquid "Locktite" locking compound be applied before retorquing. The joint shoulder bolts should be torqued to a minimum of 130 inch pounds.

B. How to adjust cams.

It is not recommended that the tightness of the step be adjusted in the field. Some minor movement of the step is considered normal. Excessive movement could be an indication of a more serious problem and the bottom cover should be removed and a thorough visual inspection should be made before any attempt is made to repair the problem by adjusting the cams. The cams are located on the inside of each side plate. Should it be deemed desirable to adjust the cams, they can be adjusted by loosening the nut on the outside of the side plate, and rotating the cam and bolt so that they bear more heavily against the step arm. Care should be taken so that both cams are adjusted approximately the same amount. After adjustment, the steps should be operated several times to insure that they are still locking over center. This can be determined by watching the steps as they complete their deployment. If the steps are locking over center, they will deploy fully and then retract approximately 1/8" as they lock in place.

C. Installation Precautions

The steps are designed to be mounted to the vehicle by at least 4 bolts. It is recommended that at least 10mm bolts and flange nuts be used. In no case should the step be welded to the vehicle. This could result in warpage, unreliable performance, and electrical damage to the module.

D. Service motor as an assembly.

It is strongly recommended that the motor/gear be serviced as an assembly and this is the way replacements are sold. After removing the splash guard, the motor/gear assembly can be replaced by disconnecting the two pin connector from the module to the motor, removing the "p" clamp holding the wire harness to the motor mount, removing the ball joint linkage from the gear, the nut holding the ground wires and removing the 4 nuts that hold the motor mount to the step top plate. Care should be taken not to disturb the adjustment in the length of the ball joint linkage. After reassembly in the reverse order, no adjustment should be required.

#### E. Module replacement.

Remove the splash guard, disconnect the nut holding the ground wires, and disconnect the 4-pin connector to the motor home wiring and the two-pin connector to the motor. Remove the four nuts holding the module in place, and reinstall the new module in the reverse order.

#### F. Lubrication

Coach Steps are equipped with self-lubricating bushings on the drive assembly and all step joints. No lubrication is necessary. If in extreme conditions lubrication is deemed necessary a silicon based grease or spray will not harm the bushing material.

If any difficulty is encountered either in the use, installation or service of the steps that is not covered in the service instructions, please call the following number for service or warranty information. The manufacturer takes no responsibility for unauthorized service or installation procedures.

1-800-275-7524

## Troubleshooting the System.

### Fully charged battery

Due to the fact that the step detects obstacles by sensing excessive current draw, it is imperative that the step be tested with a fully charged battery and test wires be of ample size to prevent current drop. Any jumpers used should be at least 12 gauge. Do not attempt to test the steps using a battery charger or bench type power supply. Even though they may supply a full 12 volts, a momentary drop in the supply may fool the module into thinking that the steps have encountered an obstacle.

### Caution

If using a battery to test the steps care should be taken to connect jumpers to the battery first and then to the steps. Battery acid can cause injury and automotive type batteries under load can produce hydrogen gas. They may explode if shorted out or if a spark ignites the hydrogen gas when the battery is connected to a load.

NOTE: Services Procedures are published as a reference for qualified professional mechanics.

WARNING: No repairs should be attempted by anyone other than a qualified professional as the deployment or retraction of the steps can cause injury if proper precautions are not taken.

### Troubleshooting the system.

1. Disconnect the plug between the chassis and the steps. Using a V.O.M. (Volt Ohm Meter) measure the voltage on the large red wire at the chassis connector with the step switch in the "on" position. The meter should indicate more than 12 volts. Turn the step switch to the off position and the meter should not indicate voltage. If the meter indicated no voltage with the switch "on", check the circuit and the circuit protectors. If it indicated less than 12 volts with the switch "on", charge the battery. If it indicated 12 volts on the red wire with the switch "off", replace the switch.
2. With the V.O.M., set to measure resistance, measure the resistance between the green wire in the plug and the frame of the vehicle. If there is more than one ohm of resistance, clean the ground eye (ground lug) or relocate the ground wire.

3. Using a V.O.M., set to resistance, test for ground on the brown wire going to the door switch. The meter should indicate an open circuit with the door closed and a path to the ground with the door open. Insure that the door is open at least 6 inches before it completes the circuit to ground.
4. With a V.O.M., check for 12 volts on the yellow wire with the ignition switch in the "on" position and no voltage with the switch in the "off" position. If there is no voltage with the switch in the "on" position, trace the circuit and repair.
5. Reconnect the steps to the chassis and proceed to test as follows. With step switch "on" and the ignition key "off" open the entry door and the steps should extend and the light should come on. About one second after the steps lock into position, the light should get brighter. You may hear a click from the module. This indicates that the module has sensed full extension and turned off the flow of current to the motor. If this does not occur, replace the electronic module.
6. If the light comes on, but the steps do not deploy, remove the step assembly from the motor home.
7. Remove the two bolts that hold the step arm collars to the drive shaft. This will allow you to operate the steps manually. If the steps do not operate freely, visually inspect for bent arms or tight joints. The shoulder bolts should rotate in the bushings with very little effort . Repair or replace as needed.
8. If the step moves freely, remove the splash guard and unplug the module from the motor assembly at the two pin connector. Connect 12 volts from the battery to the yellow wire going to the motor and ground the red wire. The gear should rotate in the deployment direction until it goes over center and comes to rest against the stop. (If the steps were deployed, reverse the wires to drive the gear in the opposite direction). If the gear and motor assembly will not function normally replace them, otherwise replace the module assembly.

## Door Switch Instructions

NOTE: The installation of the door switch is a critical part of the step installation. The switch must be installed so that any flexing to the door frame does not cause the steps to deploy. However, the switch must trip early enough when the door is opened so that the steps have time to deploy completely before the door is completely opened. Normally this means that the steps should begin to open before the door is opened by 6 inches.

Coach Step recommends the use of a switch supplied by Coach Step. However, if another switch is used it should be one that is held open in the presence of a magnet and should have a **trigger distance approximately one inch.**

The steps are designed to deploy when the door switch closes (the magnet is removed) and the switch completes the circuit to ground.

The switch should be installed approximately 6 inches above the floor on the hinge side of the door frame. The magnet should be installed on the door immediately opposite. The distance between the magnet and the switch should be determined by trial until the steps begin to deploy when the door is open approximately 6 inches.

Wires should be routed out of sight and away from sharp objects and potential snags. It is very important that a good ground is supplied in an area that is not likely to corrode, as this could cause the steps to fail to operate.

# WIRING DIAGRAM

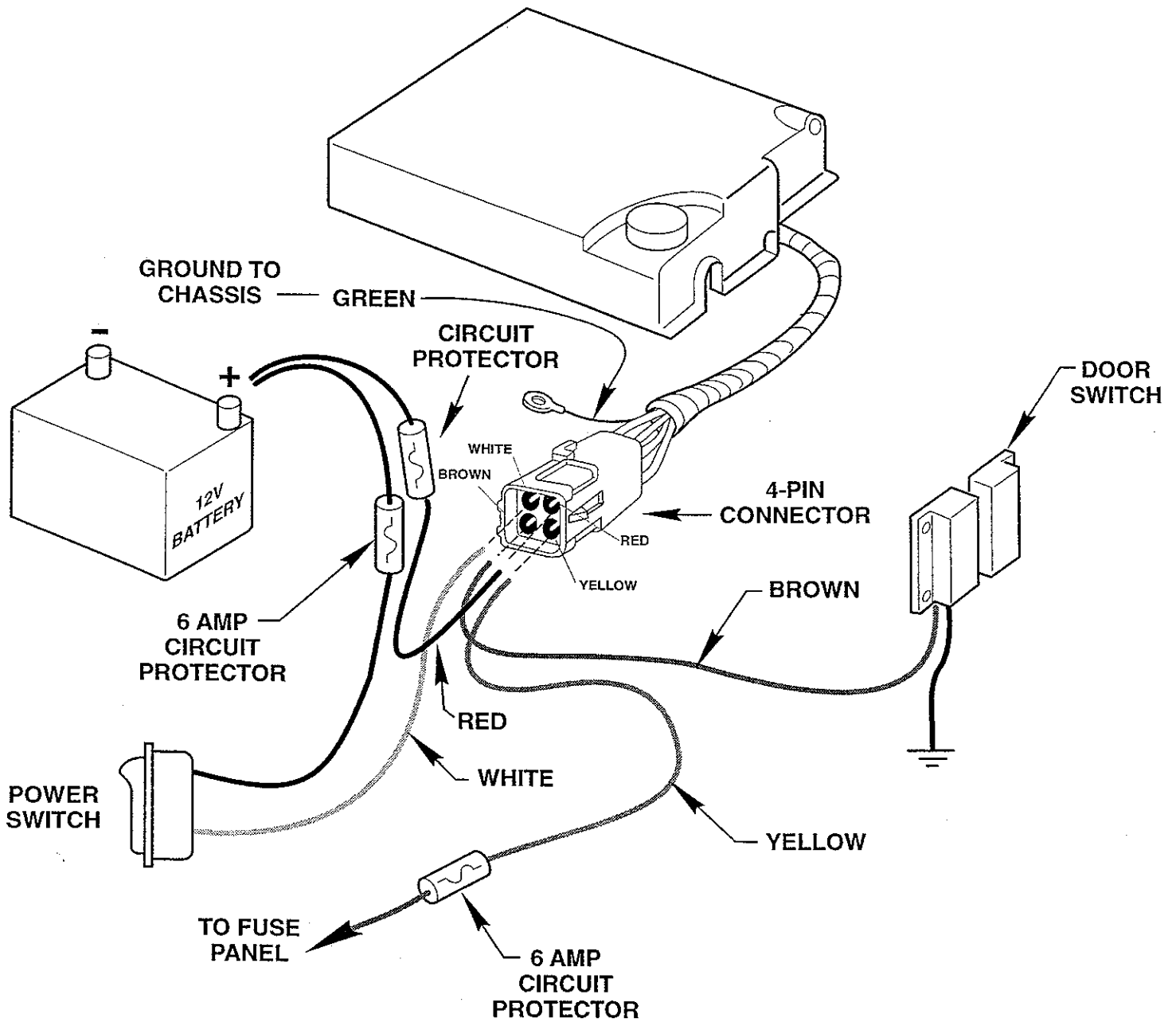

# INSTALLATION

Mount the steps to the vehicle using four 5/16-18 bolts, 5/16 lock washers, and 5/16 nuts. Retract the steps by attaching wiring in the following sequence:

1. Ground the green ground terminal to the chassis.
2. Touch the red and white wires to the positive terminal of the battery.  
**WARNING: Stand clear of the steps; they will retract quickly.**

Proceed to install door switch and power switch (these items are not included). The wires of the four pin connector must be routed as follows:

1. **WHITE:** This wire connects to the power switch; use at least 16 gauge.
2. **YELLOW:** The yellow wire must be connected to a power source that is hot only when the ignition switch is ON. Protect this circuit with a six amp fuse or circuit breaker and use at least 16 gauge wire.
3. **RED:** This wire is the power lead for the motor; connect it to the vehicle's power source using at least 10 gauge wire and 25 amp fuse protection.
4. **BROWN:** The brown wire attaches to the door switch.