



Sealed Battery Unit Smoke Alarm with Smart Hush™

• 0910

LED Indicator

A flashing red indicator light with four modes of operation: Standby, alarm mode, hush mode and memory set

Test/Reset Button

One button tests the unit's circuit operation and resets memory after an alarm condition occurs

Smart Hush™ Feature

Temporarily silences nuisance alarms. Will not allow hush to be activated unless unit is in alarm mode.

Battery Operated

No wiring needed

Sealed-In Lithium Batteries

Unit will continue to operate for 10 years



Description

The new Kidde 0910 is a 10-year, sealed battery, ionization, smoke alarm with Alarm Memory and Smart Hush™ feature. The innovative design of this alarm's automatic activation is unlike any other smoke alarm. The 0910 alarm will automatically activate when it is attached to the mounting bracket; there are no pull-tabs, no switches, everything is automatic. At the end of the alarm life, the unit will chirp, indicating the alarm is in need of replacement. The customer can use a simple tool such as a screwdriver to deactivate the unit, stopping the low battery chirp and making it safe for disposal.

The sealed-in board-mounted batteries will power the 0910 unit for its complete 10-year life. No replacement batteries will ever be needed.

Consumer Benefits

The Kidde 0910 sealed battery operated smoke alarm features a self-activation mechanism making installation simple and easy. It also features Smart Hush™ Control allowing consumers to temporarily silence nuisance alarms and an End of Life Alert indicating it is time to replace the alarm.

At the end of the alarm's 10-year life, deactivation of the alarm is just as easy. Using a tool such as a small screwdriver, a deactivation switch removes power from the alarm and renders the batteries safe for disposal. The alarm lockout feature mechanically prevents a deactivated unit from being mounted back on the mounting bracket.

Features and Benefits

- **Sealed-In Lithium Battery** – Sealed-in lithium power supply; no battery replacement required over the 10 year life of the alarm. Eliminates worry about battery removal or unauthorized deactivation of alarm.
- **Self Activation** – Alarm automatically activates when attached to the mounting bracket.
- **Alarm Memory** – Rapidly flashing LED alerts user if the alarm has sounded since the last time the test/reset button was used.
- **Smart Hush™** – Will temporarily silence nuisance alarms and will not allow hush mode to be activated unless the unit is in alarm mode.
- **Test/Reset Button** – Tests unit's circuit operation and resets memory after an alarm condition occurs.
- **End of Life Warning** – Alarm chirps every 30-45 seconds indicating the alarm is in need of replacement.
- **Tamper Resist** – (when activated upon installation) effective in preventing someone from removing the unit from the mounting bracket.
- **LED** – A flashing red indicator light with four modes of operation: standby, alarm mode, hush mode, and memory set.



Architectural and Engineering Specifications

The smoke alarm shall be Kidde unit 0910/0910CA or approved equal. It shall be powered by a non-replaceable lithium battery with a 10-year life. The lithium battery shall be sealed in the unit to prevent removal and/or tampering. The unit shall incorporate an ionization sensor with nominal sensitivity of 0.99%/ft (.87%/ft for unit 0910CA). The temperature operating range shall be between 40°F and 100°F (4°C and 38°C) and the humidity operating range shall be 5% - 95% relative humidity.

The smoke alarm can be installed on the surface of any wall or ceiling following the UL/Manufacturer's approved placement guidelines. The alarm shall incorporate an automatic activation feature that will activate the unit as soon as it is attached to the mounting bracket, no other steps are involved. The alarm shall provide optional tamper resistance that locks the unit to the mounting bracket and deters removal of the unit from the wall or ceiling.

The alarm shall include a test button that will simulate a fire condition and cause the unit to go into alarm. This sequence tests the unit's electronics to ensure proper operation.

The unit shall include a piezoelectric horn that is rated at 85 decibels at 10 feet. The unit shall include the Smart Hush™ feature that silences the unit for approximately 7 minutes if a nuisance condition occurs. The red LED will illuminate for 1.5 seconds every 8 seconds and will automatically reset itself. If the alarm is in the Hush mode and the condition that triggered the alarm persists, the alarm shall sound again to signal potential danger despite its presence in Hush Mode. The unit shall incorporate one red LED to indicate the alarm's current status and mode of operation. The LED will indicate one of four modes:

- Standby Mode:** LED will flash every 40-45 seconds to indicate the unit is operating correctly
- Alarm Mode:** LED will flash every 1.5 seconds to indicate the unit is alarming and will be accompanied by the horn sounding
- Hush Mode:** LED will illuminate for 1.5 seconds every 8 seconds to indicate the unit is temporarily silenced
- Memory Set Mode:** If Alarm Memory has been set, the LED will flash rapidly when the test button is pressed.

The unit shall include an End of Life Alert which indicates the alarm needs to be replaced. The unit will "chirp" once every 30 seconds to notify the user. The unit shall have a deactivation switch to disable it and make it safe for disposal. The unit shall at a minimum meet the requirements of UL217, NFPA72, (chapter 11 2002 edition) The State of California Fire Marshall, NFPA101 (One and two family dwellings) Federal Housing Authority (FHA), Housing and Urban Development (HUD).

Technical Specifications

Unit Number:	0910
UPC Number:	0-47871-05117-5
Power Source:	Three, 3V Lithium batteries
Sensor:	Ionization
Audio Alarm:	85dB at 10ft
Temperature Range:	40°F (4.4°C) to 100°F (37.8°C)
Humidity Range:	5%-95% relative humidity (RH)
Size:	5.6" in diameter x 1.55" depth
Weight:	1.5lbs
Interconnects:	No
LED:	Four modes of operation
Warranty:	10 year limited

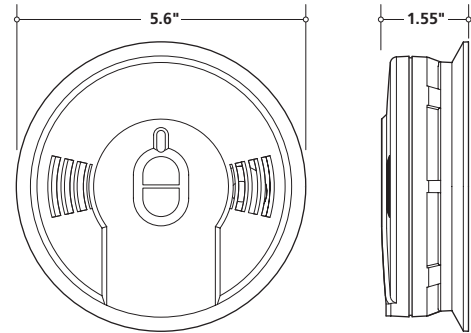

Ordering Information

Gift Box UPC: 0-47871-05117-5

Part Number	I 2 of 5	Pack Quantity	Dimensions (w x d x h inches)	Weight	Case/Skid	Layers/Skid	Skid Weight
21005187**	N/A	Individual	5.62 x 1.9 x 5.62	1.5lbs	N/A	N/A	N/A
21005117	100 47871 05117 2	Master Pack (6 units)	6.13 x 11.25 x 6.13	9.5lbs	162	6	864lbs

**Not for sale by individual unit



1394 South Third Street, Mebane NC 27302
1-800-880-6788 • www.kiddeus.com

Distributed by:

R.E. Williams Inc.
www.REWCI.com
Toll Free: 888-845-6597