

The optional 500-sheet feeder has an adjustable tray for Letter, Legal, Executive, A4, A5, ISO B5, JIS B5, and custom paper sizes.

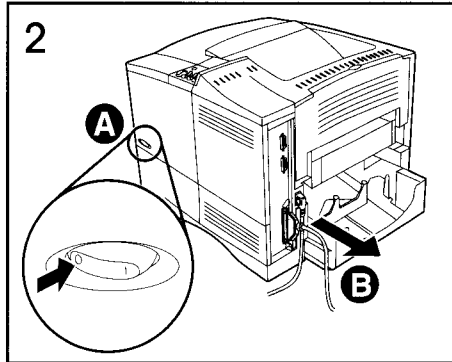

Switch the printer off (A). Unplug the power cord and remove all cables from the back of the printer (B).

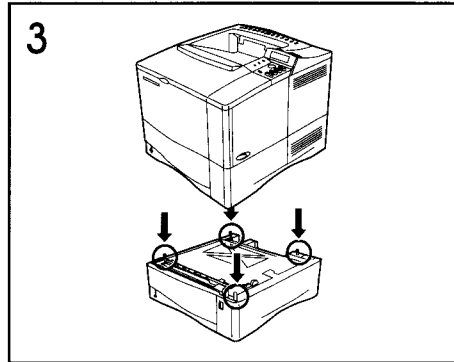

Lift the printer onto the 500-sheet feeder. Align the pins on the feeder with indentations under the printer.

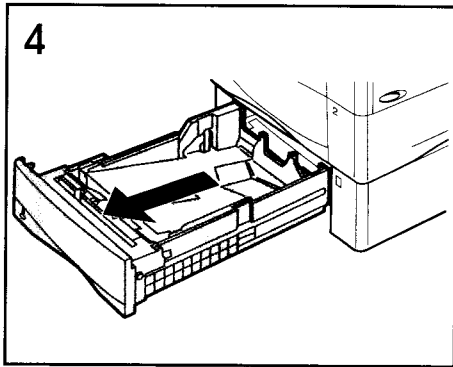

4  
Remove the tray from the feeder and place it on a flat surface.

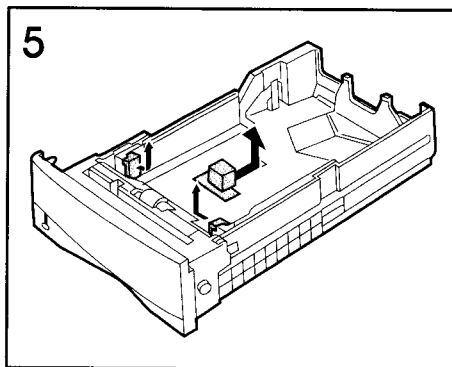

5  
Remove the shipping material from inside the tray.

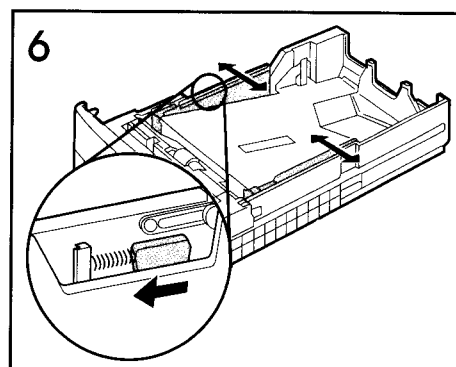

6  
If the tray is not set to the desired paper size, squeeze the release on the left guide and adjust the left and right guides to match the width of the paper.

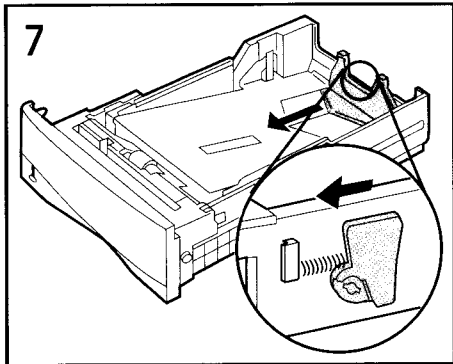

7  
Squeeze the release on the back of the rear paper guide and slide it to the desired paper size.

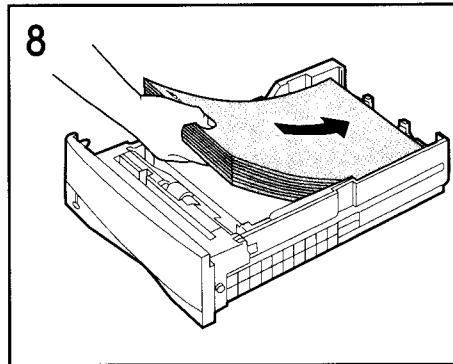

8  
Load paper into the tray.

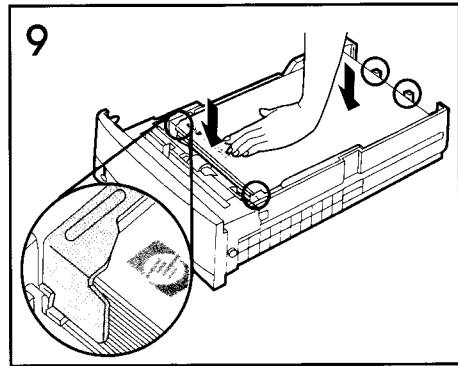

9  
Make sure the paper is flat at all four corners and below the tabs on the guides.

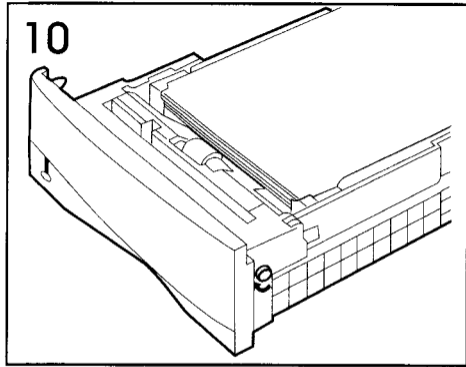

10  
Set the dial on the right side of the tray to match the paper size. Install the tray.

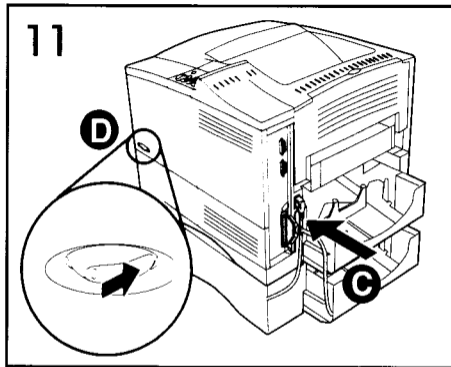

11  
Reattach the printer cables and plug in the power cord (C). Switch the printer on (D).

Note: Access the printer driver and update the settings to include the 500-sheet feeder.

# 12

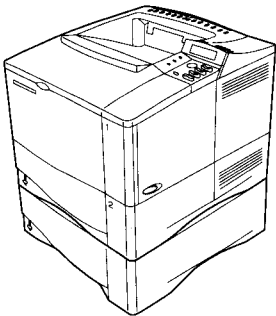
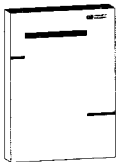

See the printer user's guide on how to print a configuration page to verify proper installation, how to use the 500-sheet feeder, how to access the printer driver, and for warranty information.