

# SLATTED SHELF

*Here's a great place to hang your hat and coat or use as a clothes rack in the kids' room. And it breaks down easily for moving or storage.*



**F**our main parts make up this project: a shelf assembly, two end brackets with curves, and a back with “Shaker-style” birch pegs. To match the pegs, I built the project from birch.

## SHELF ASSEMBLY

The shelf is made up of five slats (A) held together by three cleats (B); see page 2.

**SLATS.** To make the slats (A), first rip five pieces of  $\frac{3}{4}$ "-thick stock to a common width of  $1\frac{3}{4}$ ". Since I wanted to be able to hang the shelf on wall studs that were located 16" on center, I did a little figuring and cut the slats to 38" long.

After cutting the slats to length, round over the top edges of each slat with a  $\frac{1}{4}$ " roundover bit; refer to Fig. 3 on page 3.

**MARK POSITION OF HOLES.** Once the edges are routed, three screwholes are drilled in each slat to attach the cleats. To mark the location of these screwholes,

line up the ends of all five slats and draw lines across them with a square. Draw a line  $1\frac{3}{4}$ " from each end (this will position the brackets 32" on center), and at the exact center of the length; see Fig. 3.

**CROSSLINES.** Next, draw crosslines centered on the width of each slat. The easiest way to locate the center is with a combination square; see Fig. 1.

Set the square for just a smidgen less than half the width of a slat ( $\frac{7}{8}$ "), measure in from each edge, and put marks. Splitting the difference between the marks will locate the exact center. Then punch the centers with an awl.

**DRILL HOLES.** The screws at each of the points are sunk below the surface of the slat and covered with wood plugs; see Fig. 3. To drill the plug and screw holes, first counterbore a  $\frac{1}{2}$ "-dia. hole at each intersecting point. Then a  $\frac{3}{16}$ " hole is drilled the rest of the way through the slat to accept the shank of a screw.

**CLEATS.** With the slats complete, work can begin on the cleats (B). Since the cleats are all the same length and one end is rounded over on all of them, I found it easiest to lay out all three cleats on a single 5" wide board; see Fig. 2. Cut the board to a finished length of  $9\frac{1}{4}$ ", and then round over one edge on one end with a  $\frac{1}{4}$ " roundover bit.

**MARK PILOT HOLES.** Before cutting the cleats apart, mark the location of the pilot hole lines for the screws; see Fig. 2. First draw a line  $\frac{3}{8}$ " back from the front edge. Then draw four more lines 2" apart.

Now, the three cleats can be ripped  $1\frac{1}{2}$ " wide. To locate the pilot holes, draw crosslines centered on the width of each cleat using the same method that was used with the slats. Finally, center punch and drill a  $\frac{3}{32}$ " hole at each point.

**ASSEMBLY.** With the holes drilled in both the slats and cleats, assembly can begin. Start by screwing and gluing the

## EXPLODED VIEW

OVERALL DIMENSIONS:  
38W x 9<sup>3</sup>/<sub>4</sub>D x 10<sup>3</sup>/<sub>4</sub>H

## MATERIALS LIST

### WOOD

A	Slats (5)	3/4 x 1 3/4 - 38
B	Cleats (3)	3/4 x 1 1/2 - 9 1/4
C	Brackets (2)	3/4 x 8 7/8 - 10
D	Back (1)	3/4 x 5 - 32 3/4

### HARDWARE SUPPLIES

- (15) 1/2" -dia. Wood plugs
- (15) No. 8 x 1" Fh woodscrews
- (4) No. 8 x 1 1/4" Fh woodscrews
- (1) 3/8" -dia. x 4" -long Dowel rod
- (4) 7/8" -dia. x 3 3/8" -long Birch Shaker pegs
- (2) 9/16" x 1 11/16" Keyhole hangers w/screws

## CUTTING DIAGRAM

3/4 x 5 1/2 - 48 (1.8 Bd. Ft.)



3/4 x 5 1/2 - 48 (1.8 Bd. Ft.)



3/4 x 5 1/2 - 48 (1.8 Bd. Ft.)

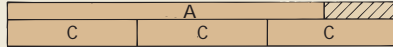

3/4 x 5 1/2 - 48 (1.8 Bd. Ft.)

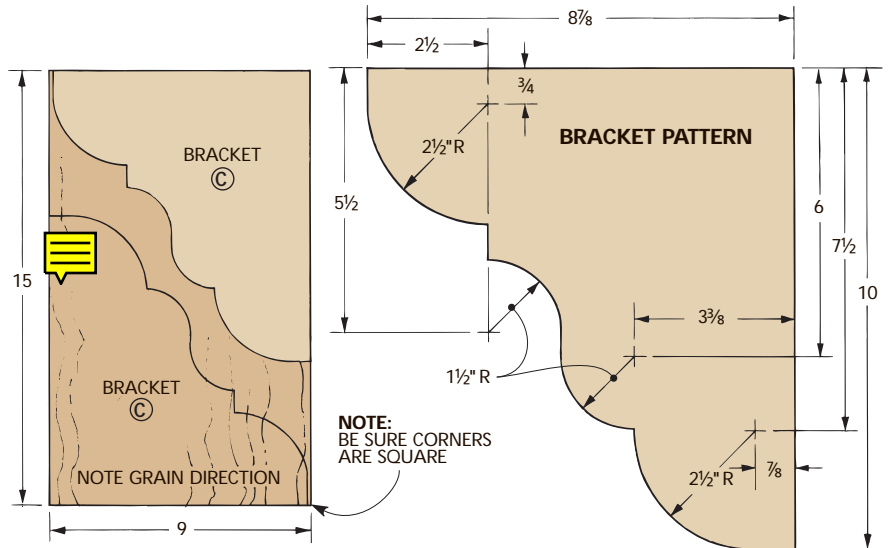
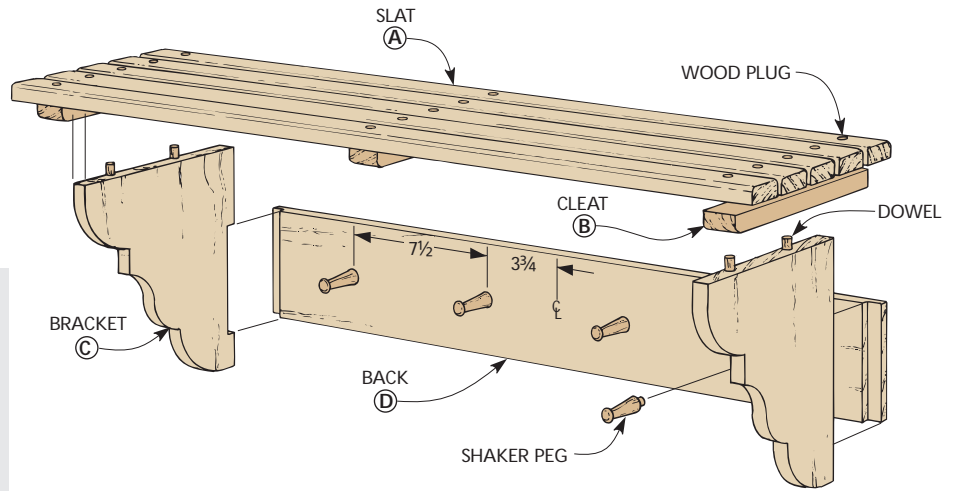
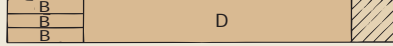

two outside cleats to the first and last slats; see Fig. 3. Make sure this partial assembly is square. Then screw and glue the remaining slats and cleats together.

The final step on the shelf assembly is to glue plugs into the counterbores. Then chisel or cut them off and sand flush.

## BRACKETS

The completed shelf assembly rests on two brackets (C). Both brackets are cut out of a single 9" x 15" blank made from glued-up stock; see drawing above.

After the blank is squared up, lay out a

cardboard template; see the Bracket Pattern above. Then use the template to trace the brackets on the blank. Now cut, file, and sand them smooth.

**MORTISE FOR KEYHOLE HANGER.** The shelves are held on the wall with two nifty little metal keyhole hangers. (They're available from many woodworking mail order catalogs.) To hold a hanger in each bracket, a 3/16"-deep, 9/16"-wide mortise is routed on the back edge; see Fig. 4. Rout the mortise by making two passes with a 1/2" straight bit on a router table or with a hand-held router and edge guide.

After the mortise is routed, a section of the slot needs to be drilled out to accept the head of the screw that will be in the wall; see Fig. 5.

Finally, drill holes and screw the keyhole hanger into the mortise; see Fig. 6.

**STOPPED RABBET.** Next, a stopped rabbet is routed on the inside back edge of each bracket to accept the back (D); see Fig. 7.

Since the stopped rabbet is to be 3/8" wide and 5/8" deep, a 3/8" rabbeting bit can be used to cut it; see Fig. 7. Start and stop the cut just a bit short of the end lines and clean it up with a sharp chisel.

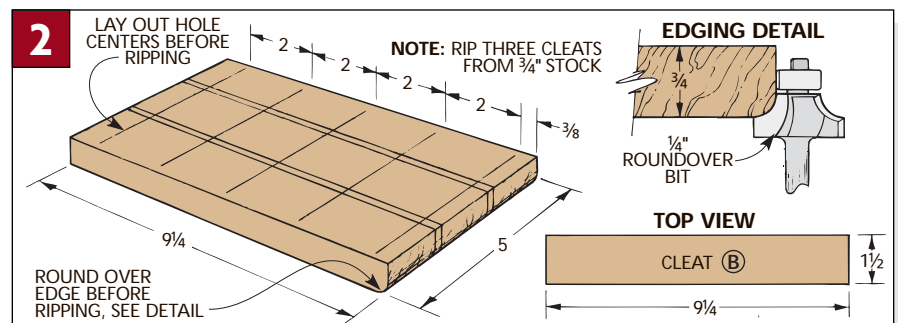
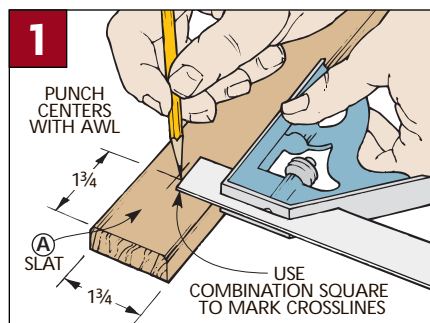

**MOUNTING THE BRACKETS.** After the rabbets are routed, the brackets are mounted under the shelf assembly. I decided not to fasten the brackets permanently since I wanted to be able to take the unit apart for moving or storage. Rather, I used two short pins (dowels) in the top of each bracket to locate and stabilize the assembly; see Fig. 8.

To mount the pins, drill two holes in the bottom of the second and fourth slats. The holes are centered on the widths of these slats and located  $\frac{3}{8}$ " from the inside edge of the two cleats; see Fig. 8.

**USING DOWEL CENTERS.** After drilling the holes in the slats, use  $\frac{3}{8}$ " dowel centers to mark the location of the matching holes on the top edge of the brackets. Then drill these holes.

Finally, glue two short dowels into the top of each bracket to act as locating pins. Then round over the end of each dowel with sandpaper to help them slide into the matching holes.

## BACK

The final piece to cut is the back (D). It's ripped to a width of 5" (to match the stopped rabbet on the bracket).

To determine the length of the back, turn the shelf assembly upside down and hold the brackets straight up against the cleats. Then measure the distance between the brackets and add the depth of both rabbets (in my case,  $32\frac{3}{4}$ ").

After the back is cut to final length, rabbet the ends to produce  $\frac{3}{8}$ "-thick tongues that fit in the stopped rabbets in the brackets; see Fig. 9. Then round over the front edges with a  $\frac{1}{4}$ " roundover bit.

**SHAKER PEGS.** Now locate and drill  $\frac{1}{2}$ " holes,  $\frac{3}{8}$ " deep as shown in the Exploded View on page 2. And then glue in the Shaker Pegs.

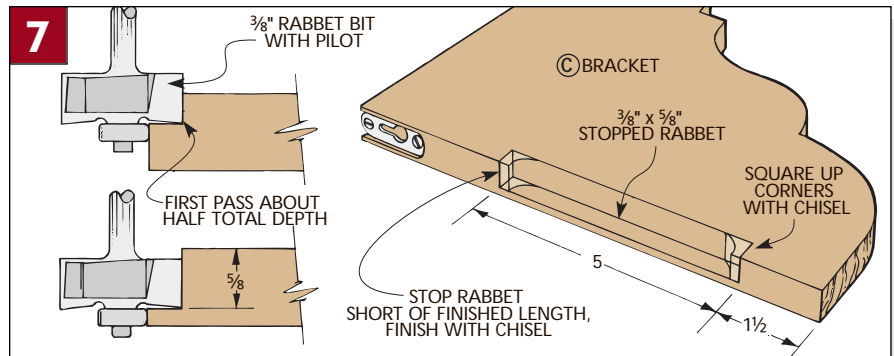
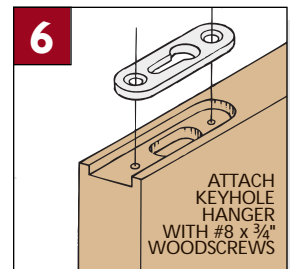
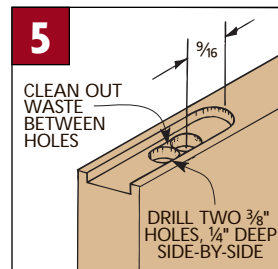
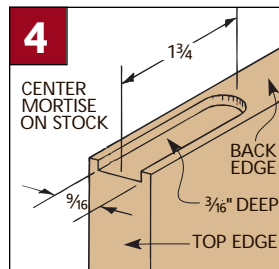
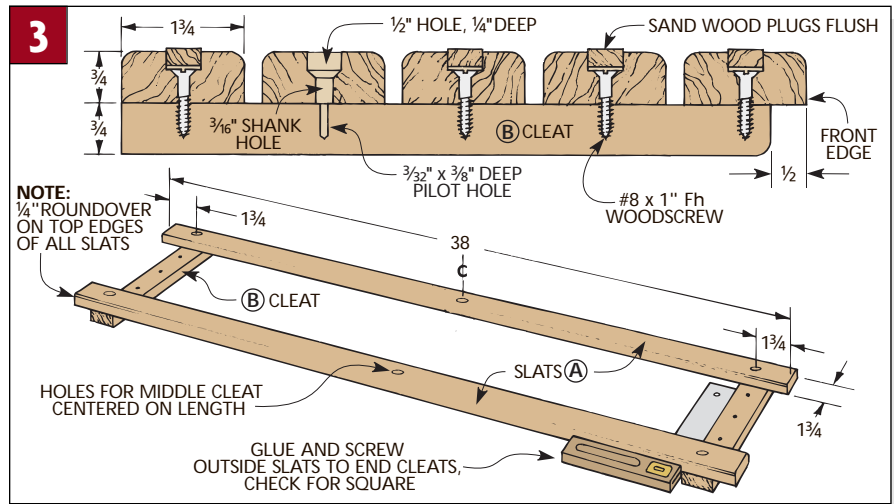

**ATTACHING THE BACK.** Finally, the back is placed in the stopped rabbets in the brackets and holes are drilled for

**FINISH.** To finish the shelf, I sanded all the surfaces smooth and then applied two coats of General Finishes Royal Finish (a tung oil/urethane mixture). ■

