

# YAKIMA

# Raptor

# US

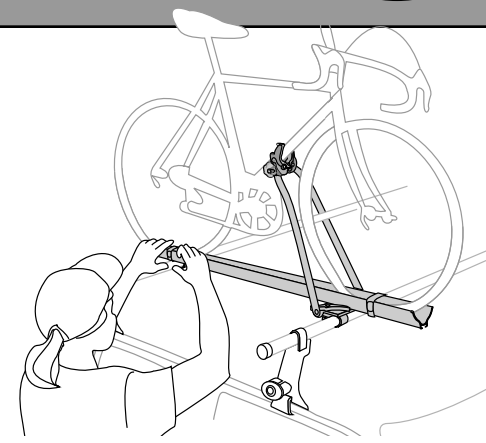
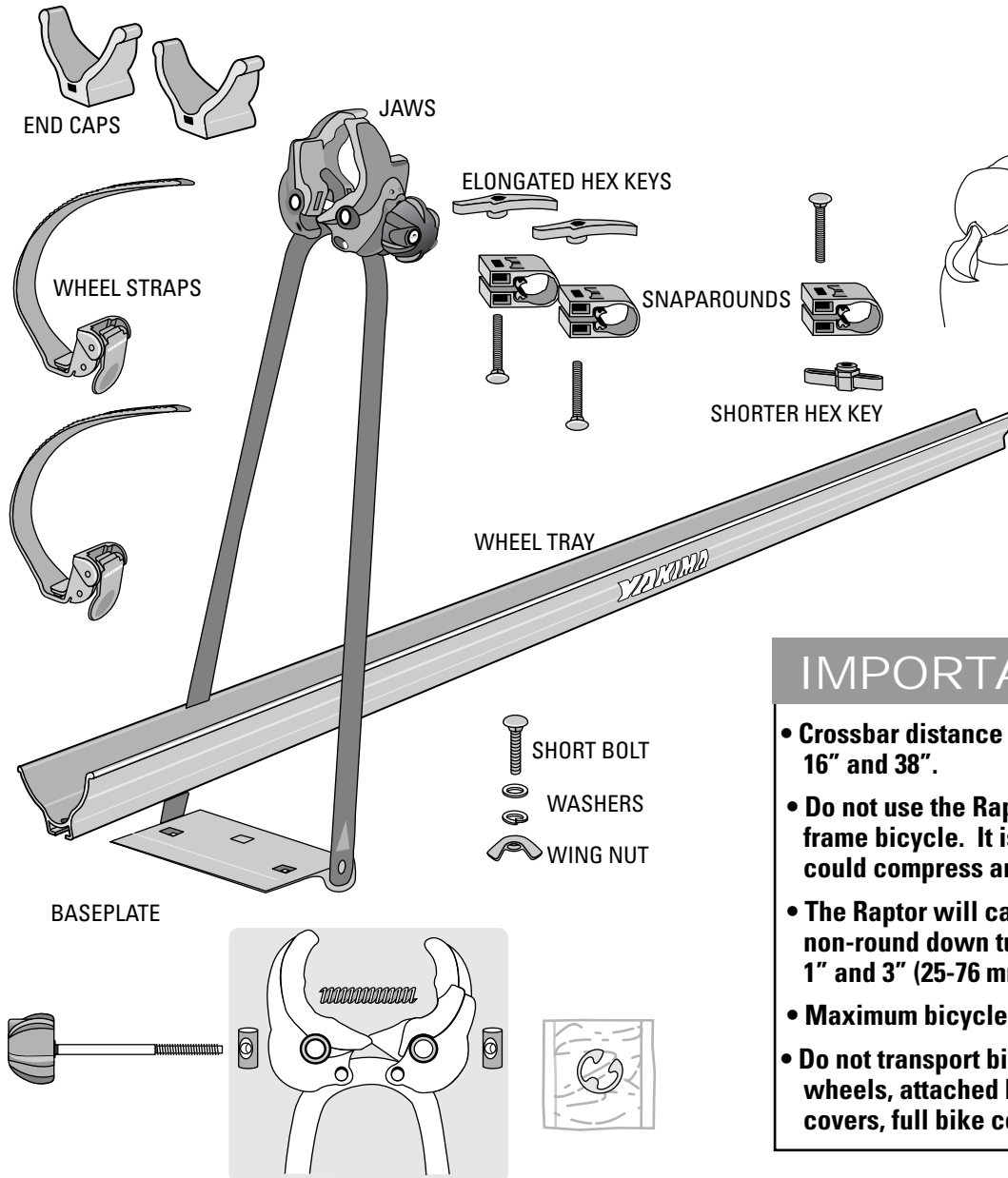

## IMPORTANT:

- Crossbar distance must be between 16" and 38".
- Do not use the Raptor with any carbon fiber frame bicycle. It is possible that the Jaws could compress and damage the frame.
- The Raptor will carry bikes with round and non-round down tubes with diameters between 1" and 3" (25-76 mm) only.
- Maximum bicycle weight: 35 lbs. / 16kg.
- Do not transport bicycles with solid disk wheels, attached baby seats, panniers, wheel covers, full bike covers, or motors.

**IMPORTANT WARNING!**  
IT IS CRITICAL THAT ALL YAKIMA RACKS AND ACCESSORIES BE PROPERLY AND SECURELY ATTACHED TO YOUR VEHICLE. IMPROPER ATTACHMENT COULD RESULT IN AN AUTOMOBILE ACCIDENT, AND COULD CAUSE SERIOUS BODILY INJURY OR DEATH TO YOU OR TO OTHERS. YOU ARE RESPONSIBLE FOR SECURING THE RACKS AND ACCESSORIES TO YOUR CAR, CHECKING THE ATTACHMENTS PRIOR TO USE, AND PERIODICALLY INSPECTING THE PRODUCTS FOR ADJUSTMENT, WEAR, AND DAMAGE. THEREFORE, YOU MUST READ AND UNDERSTAND ALL OF THE INSTRUCTIONS AND CAUTIONS SUPPLIED WITH YOUR YAKIMA PRODUCT PRIOR TO INSTALLATION OR USE. IF YOU DO NOT UNDERSTAND ALL OF THE INSTRUCTIONS AND CAUTIONS, OR IF YOU HAVE NO MECHANICAL EXPERIENCE AND ARE NOT THOROUGHLY FAMILIAR WITH THE INSTALLATION PROCEDURES, YOU SHOULD HAVE THE PRODUCT INSTALLED BY A PROFESSIONAL INSTALLER SUCH AS A QUALIFIED GARAGE OR AUTO BODY SHOP.

Part #1033038 Rev.H

# Wheel Tray/Hoop Assembly

## 1 ATTACH WHEEL TRAY TO HOOP ASSEMBLY.

- Insert short bolt head 8" into slot in wheel tray.
- Use the washers and wing nut to attach the hoop baseplate onto this bolt.
- Slide one SnapAround bolt into the track at the other end of the wheel tray.

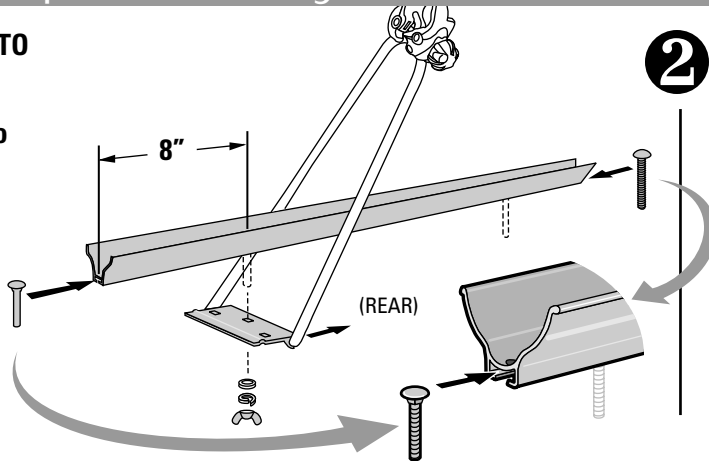

## 2

Slide the open wheel straps onto the wheel tray with the red buttons towards you.

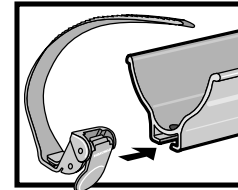

### ON SOME SMALLER BIKES—

If the wheel straps need to be between the crossbars, slide them onto the wheel tray now. If not, install them after the next step.

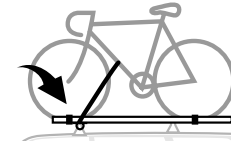

STANDARD BIKES:  
Place wheel straps outside the crossbars.

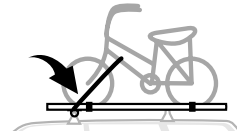

SMALLER BIKES:  
Wheel straps may need to go between the crossbars.

# Red Knob and Jaws Assembly

## 3 Install red knob:

- Choose access from passenger or driver side.
- Red knob should face you when the Raptor is attached to wheel tray.

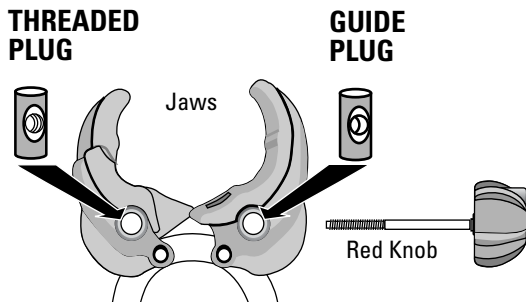

## 4

- Place the GUIDE PLUG into the hole on one side of the jaws.
- Slide the red knob's bolt threads through the guide plug.

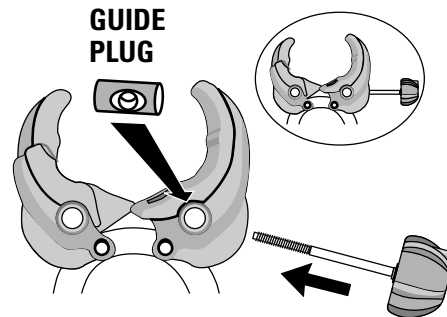

## 5

- Insert the THREADED PLUG into the other hole.
- Place spring between guide plug and threaded plug.
- Slide knob through spring and into threaded plug.

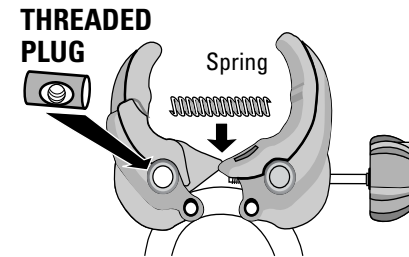

## 6

- Turn the red knob clockwise to engage the threaded plug.

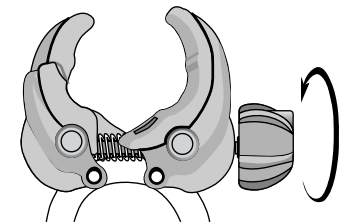

## 7

- Tighten knob completely until threaded end is exposed.

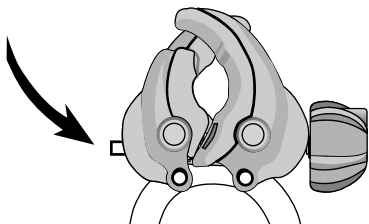

## 8

- Slide the "E" clip into groove on end. A coin or a key may provide added leverage.

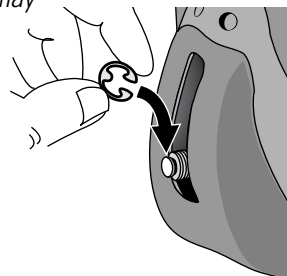

## 9

- Open red knob completely.

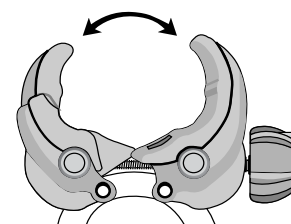

SKS® Lock Cores are optional.

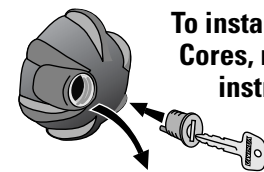

To install SKS® Lock Cores, refer to lock instructions.

NOTE:  
If not using lock, leave plug in.

# DO YOU HAVE - SQUARE - ROUND - OR OTHER - CROSSBARS?

## SQUARE

### 10 SNAP AROUNDS:

Loosen the tabs by bending them repeatedly.

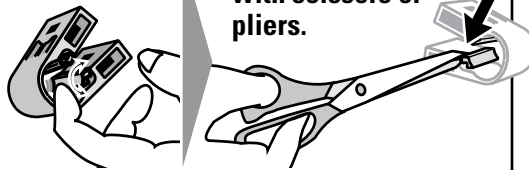

Remove the tabs with scissors or pliers.

## ROUND

### 11

#### SNAP AROUNDS:

Attach 2 on the front crossbar and 1 on the back crossbar.

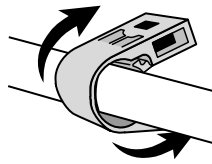

### 12

#### Set tray/hoop assembly onto crossbars.

- Insert two bolts up through the SnapArounds and baseplate.
- Secure with elongated hex keys.
- Insert the remaining bolt through the SnapAround on the other crossbar.
- Secure with short hex key.

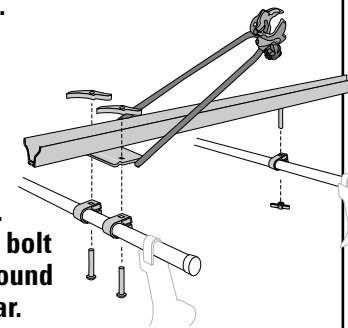

### 13

Tighten all 3 hex keys firmly onto all SnapArounds.

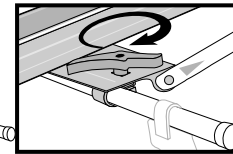

**NOTE:** Hoop must rest horizontally on tray while turning the hex keys. When hoop is raised the hex keys cannot be turned.

## OTHER

### 11

#### MIGHTY MOUNTS:

Attach 2 on the front crossbar and 1 on the back crossbar.

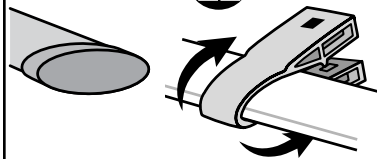

### 12

#### Set tray/hoop assembly onto crossbars.

- Insert two MightyMount bolts down through the MightyMounts and baseplate.
- Tighten with hex wrench.
- Insert a SnapAround bolt through the SnapAround on the other crossbar.
- Secure with short hex key.

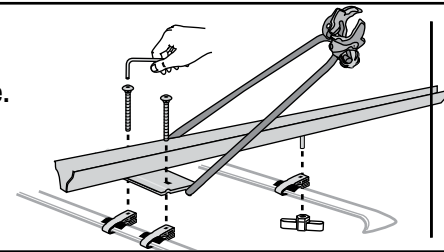

### 13

Tighten rear hex key firmly onto SnapAround..

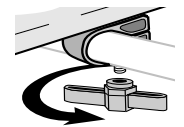

Universal MightyMount #03590  
Follow the Universal MightyMount instructions and refer to this Raptor instruction for correct installation.

### 14

#### INSTALL END CAPS.

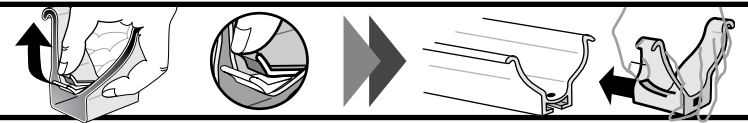

## Securing your bike.

### 15

Set your bicycle in the wheel tray with the hoop lying flat between the wheels.

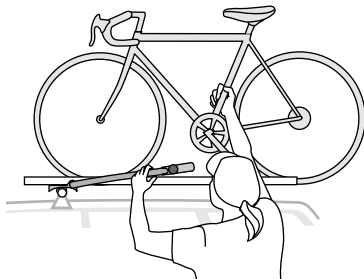

**NOTE:** The front wheel of the bicycle must rest inside the hoop.

### 16

**RAISE** hoop, **ROLL** bicycle forward as jaws meet the down tube.

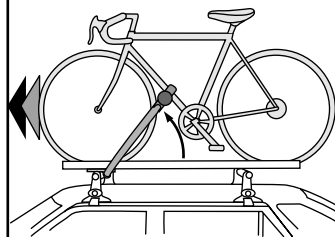

### 17

In the open position, Jaws should clear the bike frame. Raptor can mount above or below most attachments, such as waterbottles.

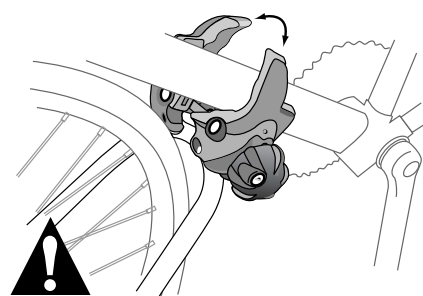

**SOME** attachments on the down tube must be removed if the jaws cannot attach above or below them.

**NOTE:**  
To avoid paint wear, clean contact points on frame before tightening Jaws.

### 18

Tighten red knob.

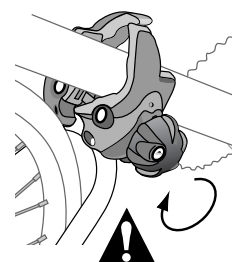

Do not overtighten.

**19** Pull the strap through wheel spokes on the front and rear wheels.

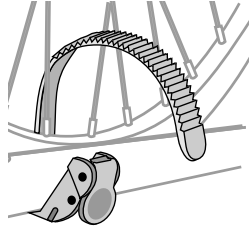

*Do not let the strap push against the valve stem.*

**20** CLOSE THE STRAPS.

- Insert the strap end behind the red tab.
- TIGHTEN the strap by repeatedly lifting the red tab.

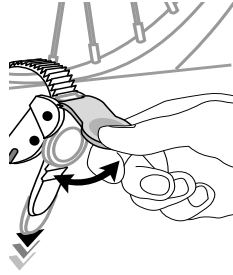

**!** DO NOT OVERTIGHTEN THE STRAP!

**21** If the wheel is still loose in the tray slide the strap in the tray until it rests against the rim. TIGHTEN AGAIN.

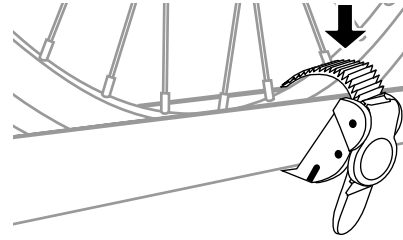

**TECHNICAL ASSISTANCE OR REPLACEMENT PARTS:**  
Please contact your dealer or call us at (888) 925-4621  
Monday through Friday  
7:00 A.M. to 5:00 P.M. PST.

To unload bicycle:

**22** Release the strap by pushing the red button.

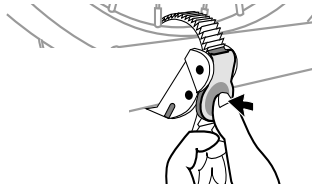

**23** Unscrew red knob and roll bicycle out of hoop.

**BEFORE DRIVING AWAY:**

**CHECK BOTH WHEEL STRAPS**  
*Tighten the straps if needed.*

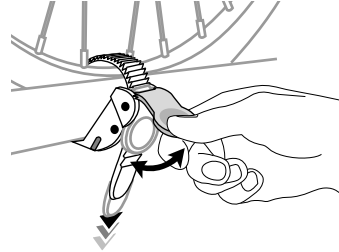

**!** DO NOT OVERTIGHTEN THE STRAPS!

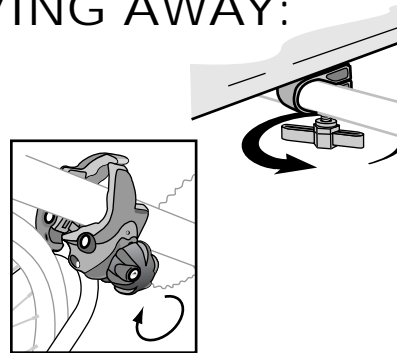

**CHECK THE HEX KEYS AND THE RED KNOB.**  
*If they are loose, tighten them.*



This product is covered by YAKIMA's "Love It Till You Leave It" Limited Lifetime Warranty

To obtain a copy of this warranty, go online to [www.yakima.com](http://www.yakima.com) or email us at [yakwarranty@yakima.com](mailto:yakwarranty@yakima.com)

or call (888) 925-4621

OFF-ROAD DRIVING is not recommended and could result in damage to your vehicle or your bike.

**ATTACHMENT HARDWARE CAN LOOSEN OVER TIME. CHECK AND TIGHTEN IF NECESSARY, BEFORE EACH USE.**



DO NOT TRANSPORT BICYCLES WITH attached baby seats, panniers, wheel covers, full bike covers or motors.

**KEEP THESE INSTRUCTIONS!**