

SPECIFICATIONS

Parameters		pH	Conductivity	Turbidity	Dissolved oxygen	Temperature	Salinity	
Principle		Glass electrode	Alternating four-electrode	Scattering/transmitting light	Membrane/galvanic cell	Thermistor	{ Alternating four-electrode }*	
Range		0-14 pH	0-100 mS/cm	0-800 NTU	0-19.9 mg/l	0-50°C	0-4 %	
Resolution	Standard	0.1pH	(mS/cm) (mS/cm) 0-1 : 0.01 1-10 : 0.1 10-100 : 1	10 NTU	0.1 mg/l	1 °C	0.1°C	
	Expanded	0.01pH	(mS/cm) (mS/cm) 0-1 : 0.001 1-10 : 0.01 10-100 : 0.1	1 NTU	0.01 mg/l	0.1°C	0.01°C	
Repeatability		±0.05pH	±1%of full scale	±3%of full scale	±0.1 mg/l	±0.3°C	±0.1°C	
Temp. compensation		0-50°C	0-50°C	—	0-40°C	—	—	
Calibration		Auto one-point calibration, manual two-point calibration	Auto one-point calibration, manual two-point calibration	Auto one-point calibration, manual two-point calibration	Auto one-point calibration(air), manual two-point calibration	—	—	
Display		LCD						
Printer output		Centronics						
Power		Battery 6F22(S-006P)×1pc.						
Sensor assembly		Standard : sensor with 2 m cable, Optional : sensor with 10 m cable						
Weight		Main unit : approx. 400g (0.9 lb), Sensor assembly (2 m cable) : approx. 800 g (1.8 lb)						

*Salinity is calculated from the conductivity data.

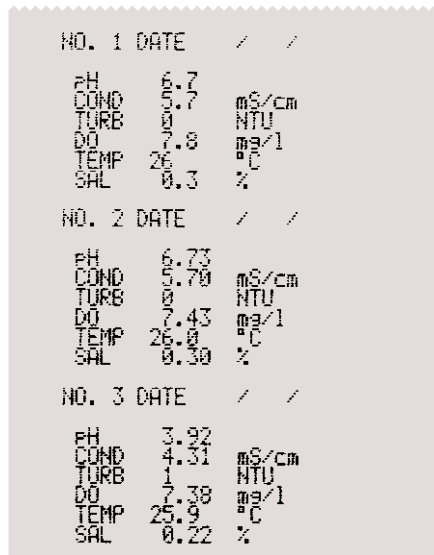

Data stored in memory can be printed out on any printer with Centronics interface.

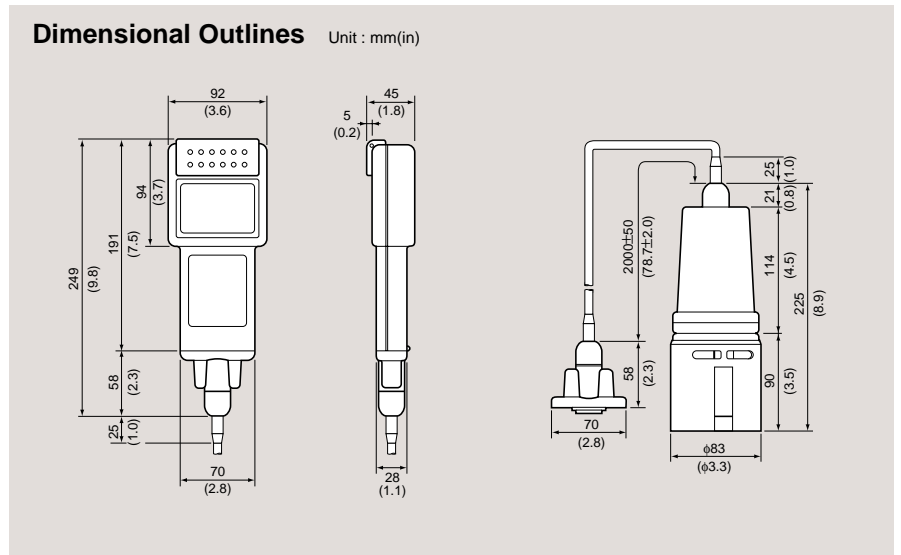

⚠ Please read the operation manual before using this product to assure safe and proper handling of the product.

Simple, Handy Instrument Contains Powerful Sensor for

The Horiba U-10 water quality checker brings laboratory accuracy and the ease of push-button operation to water quality measurement in the field. Six parameters can be measured : pH, temperature, dissolved oxygen, electrolytic conductivity, turbidity, and, salinity. Featuring a powerful sensor and state-of-the-art functions, the U-10 makes it easy to get highly reliable water quality data simply and quickly just by submersing the sensor in the water. The U-10 is flexible enough to use for checking the quality of a broad range of water samples, from factory effluent to urban drainage, river water, lake and marsh water, aquatic culture tanks, agricultural water supplies, and sea water. The main unit is water-resistant, so it can be used safely even in the rain.

Automatic salinity correction function makes it possible to measure DO in both fresh water and salt water

It is now possible to measure DO in either fresh or salt water with the same instrument. When measuring DO in salt water, it will automatically measure the salt concentration and make the salinity correction. It is also possible to set a freely selectable salinity correction factor of between 0 and 4 percent.

Automatic calibration function calibrates the instrument simply at the touch of a button for more highly reliable data

what used to be a complicated calibration process is now easy. Just fill the supplied beaker with the standard solution, immerse the sensor and press a button once for one-point calibration for each of the four parameters pH, conductivity, turbidity and DO. Two-point calibration is also possible should more precise data be required.



20 samples of data on 6 parameters can be stored in memory to be recalled later for display and print out
Store the results of measurement of all six parameters for up to 20 samples. There is no need to record measured values on site. Data stored in memory can be recalled and displayed at any time, and can even be simultaneously printed out on any standard printer by connecting it to the Centronics-specification printer output terminals.



Simultaneous Measurement of Six Parameters

Expanded display function handles any need for more precise data

If more precise data is needed, select the expanded display mode to display data on any parameter to one more digit of resolution.

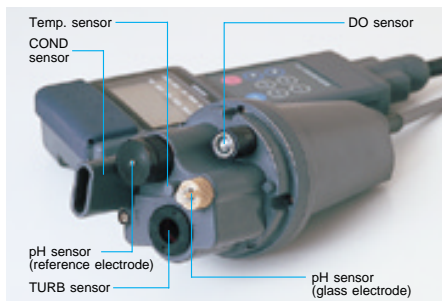

Direct-submersion sensor, no need to collect samples

The U-10 sensor measures by being directly submersed in the river, sea or other water. Forget troublesome sampling. The standard cable length is two meters, but the sensor is constructed to be able to withstand water pressure at depths of up to 10 meters and is thus suitable for an even wider range of applications if used with the optional 10-meter cable.

Data back-up function keeps data safe even if batteries run down

The U-10 features a data back-up function to ensure that precious data is never lost by accident. Sensor calibration values and stored data remain safely in the memory even if the batteries run down.

No need to worry even if you forget to switch off the power

Attention to the smallest detail has resulted in an automatic energy-saving function that switches the instrument off automatically any time 30 minutes pass without any key being pressed.

Powerful sensor gives precise data

pH

Glass electrode. The glass electrode and reference electrode are of the cartridge type so they are simple to replace and require no maintenance.

Conductivity

Alternating four-electrode cell resistant to the effect of polarization. Gives reliable, stable data even at high concentrations. Range switches automatically to the most appropriate of three --- 0-1 mS/cm, 1-10 mS/cm, or 10-100 mS/cm --- depending upon the sample.

Turbidity

Ratio of transmitted to scattered light. The light source is an LED. This method gives a broader measurement range than optical systems based purely on transmitted light or scattered light and is little affected by particle coloration, thus giving highly dependable data.

DO

Membrane/galvanic cell. Capable of stable data display, unaffected by coexisting gases other than oxygen. The electrode is of the cartridge type.

Temperature

Thermistor. Can measure from 0 to 50°C. Also used for automatic temperature compensation when measuring pH, DO and conductivity.

Salinity

Computed from conductivity data. Measurement range is 0 to 4 percent.

Carrying case (included)

